

5370B UNIVERSAL TIME INTERVAL COUNTER

GENERAL INFORMATION
INSTALLATION
OPERATING AND PROGRAMMING
PERFORMANCE TESTS
ADJUSTMENTS
REPLACEABLE PARTS
MANUAL CHANGES
SERVICE

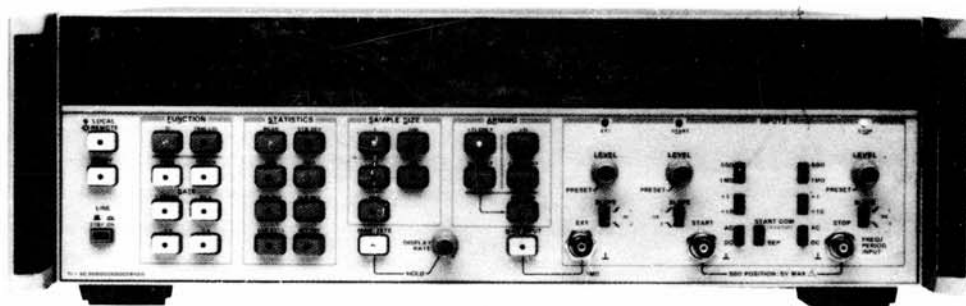

 **HEWLETT
PACKARD**

Reproduced with Permission, courtesy of Agilent Technologies, Inc.
The HP manual is dated October 1995, but pages 3-25 to 3-31
inclusive are not from that manual, but from one dated May 1987
PDF produced 12 May 2005 by Dr. David Kirkby, G8WRB.
NOT FOR RESALE.

150 dpi - see <http://www.g8wrb.org.uk/time/HP-5370B/> for other resolutions.

About this Manual

We've added this manual to the Agilent website in an effort to help you support your product. This manual is the best copy we could find; it may be incomplete or contain dated information. If we find a more recent copy in the future, we will add it to the Agilent website.

Support for Your Product

Agilent no longer sells or supports this product. Our service centers may be able to perform calibration if no repair parts are needed, but no other support from Agilent is available. You will find any other available product information on the Agilent Test & Measurement website, www.tm.agilent.com.

HP References in this Manual

This manual may contain references to HP or Hewlett-Packard. Please note that Hewlett-Packard's former test and measurement, semiconductor products and chemical analysis businesses are now part of Agilent Technologies. We have made no changes to this manual copy. In other documentation, to reduce potential confusion, the only change to product numbers and names has been in the company name prefix: where a product number/name was HP XXXX the current name/number is now Agilent XXXX. For example, model number HP8648A is now model number Agilent 8648A.

CERTIFICATION

Hewlett-Packard Company certifies that this product met its published specifications at the time of shipment from the factory. Hewlett-Packard further certifies that its calibration measurements are traceable to the United States National Bureau of Standards, to the extent allowed by the Bureau's calibration facility, and to the calibration facilities of other International Standards Organization members.

WARRANTY

This Hewlett-Packard instrument product is warranted against defects in material and workmanship for a period of one year from date of shipment. During the warranty period, Hewlett-Packard Company will, at its option, either repair or replace products which prove to be defective.

For warranty service or repair, this product must be returned to a service facility designated by HP. Buyer shall prepay shipping charges to HP and HP shall pay shipping charges to return the product to Buyer. However, Buyer shall pay all shipping charges, duties, and taxes for products returned to HP from another country.

HP warrants that its software and firmware designated by HP for use with an instrument will execute its programming instructions when properly installed on that instrument. HP does not warrant that the operation of the instrument, or software, or firmware will be uninterrupted or error free.

LIMITATION OF WARRANTY

The foregoing warranty shall not apply to defects resulting from improper or inadequate maintenance by Buyer, Buyer-supplied software or interfacing, unauthorized modification or misuse, operation outside of the environmental specifications for the product, or improper site preparation or maintenance.

NO OTHER WARRANTY IS EXPRESSED OR IMPLIED. HP SPECIFICALLY DISCLAIMS THE IMPLIED WARRANTIES OF MERCHANTABILITY AND FITNESS FOR A PARTICULAR PURPOSE.

EXCLUSIVE REMEDIES

THE REMEDIES PROVIDED HEREIN ARE BUYER'S SOLE AND EXCLUSIVE REMEDIES. HP SHALL NOT BE LIABLE FOR ANY DIRECT, INDIRECT, SPECIAL, INCIDENTAL, OR CONSEQUENTIAL DAMAGES, WHETHER BASED ON CONTRACT, TORT, OR ANY OTHER LEGAL THEORY.

ASSISTANCE

Product maintenance agreements and other customer assistance agreements are available for Hewlett-Packard products.

For any assistance, contact your nearest Hewlett-Packard Sales and Service Office. Addresses are provided at the back of this manual.

HP 5370B UNIVERSAL TIME INTERVAL COUNTER

OPERATING AND SERVICE MANUAL

HP 5370B SERIAL PREFIX: 2904

This manual applies directly to HP 5370B's having serial number prefix 2904.

NEWER INSTRUMENTS

This manual, with enclosed "Manual Changes" sheet, applies to HP 5370B's having serial number prefixes as listed on the "Manual Changes" sheets.

OLDER INSTRUMENTS

For serial prefixes below 2904, refer to Section VII for manual backdating.

©HEWLETT-PACKARD COMPANY 1983, 1987, 1995
5301 STEVENS CREEK BLVD, SANTA CLARA, CA 95052-8059

MANUAL PART NUMBER : 05370-90031

Printed: OCTOBER 1995



SAFETY CONSIDERATIONS

GENERAL

This product and related documentation must be reviewed for familiarization with safety markings and instructions before operation.

This product is a Safety Class I instrument (provided with a protective earth terminal).

BEFORE APPLYING POWER

Verify that the product is set to match the available line voltage and the correct fuse is installed. Refer to Section II, Installation.

SAFETY EARTH GROUND

An uninterruptible safety earth ground must be provided from the mains power source to the product input wiring terminals or supplied power cable.

ACOUSTIC NOISE EMISSION: LpA 50 dB at operator position, at normal operation, tested per ISO 7779. All data are the results from type test.

GERAeUSCHEMISSION: LpA <50 dBm Arbeitsplatz, normaler Betrieb, Geprueft nach DIN 456365 Teil 19. Die Angaben beruhen auf Ergebnissen von Typpruefungen.

SAFETY SYMBOLS



Instruction manual symbol; the product will be marked with this symbol when it is necessary for the user to refer to the instruction manual.



Indicates hazardous voltages.



Indicates terminal is connected to chassis when such a connection is not apparent.



Alternating current.



Direct current.

WARNING

This denotes a hazard. It calls attention to a procedure, practice, or the like, which, if not correctly performed or adhered to, could result in personal injury. Do not proceed beyond a **WARNING** sign until the indicated conditions are fully understood and met.

CAUTION

This denotes a hazard. It calls attention to an operating procedure, practice or the like, which, if not correctly performed or adhered to, could result in damage to or destruction of part or all of the product. Do not proceed beyond a **CAUTION** sign until the indicated conditions are fully understood and met.

SAFETY INFORMATION

WARNING

Any interruption of the protective grounding conductor (inside or outside the instrument) or disconnecting the protective earth terminal will cause a potential shock hazard that could result in personal injury. (Grounding one conductor of a two conductor outlet is not sufficient protection.)

Whenever it is likely that the protection has been impaired, the instrument must be made inoperative and be secured against any unintended operation.

If this instrument is to be energized via an autotransformer (for voltage reduction) make sure the common terminal is connected to the earthed pole terminal (neutral) of the power source.

Instructions for adjustments while covers are removed and for servicing are for use by service-trained personnel only. To avoid dangerous electric shock, do not perform such adjustments or servicing unless qualified to do so.

For continued protection against fire, replace the line fuse(s) only with 250V fuse(s) of the same current rating and type (for example, normal blow, time delay). Do not use repaired fuses or short-circuited fuseholders.

When measuring power line signals, be extremely careful and always use a step-down isolation transformer whose output voltage is compatible with the input measurement capabilities of this product. This product's front and rear panels are typically at earth ground, so **NEVER TRY TO MEASURE AC POWER LINE SIGNALS WITHOUT AN ISOLATION TRANSFORMER.**

TABLE OF CONTENTS

Section	Title	Page
SECTION I - GENERAL INFORMATION		1-1
1-1.	INTRODUCTION	1-1
1-4.	SPECIFICATIONS.....	1-1
1-6.	INSTRUMENTS COVERED BY MANUAL	1-1
1-13.	HP-IB INTERFACING, AND PROGRAMMING INFORMATION	1-4
1-15.	SAFETY CONSIDERATIONS.....	1-4
1-17.	DESCRIPTION	1-4
1-21.	OPTIONS	1-5
1-24.	ACCESSORIES SUPPLIED	1-5
1-26.	EQUIPMENT AVAILABLE	1-5
1-28.	RECOMMENDED TEST EQUIPMENT.....	1-5
SECTION II - INSTALLATION		2-1
2-1.	INTRODUCTION	2-1
2-3.	INITIAL INSPECTION	2-1
2-5.	PREPARATION FOR USE	2-1
2-6.	Power Requirements.....	2-1
2-8.	Line Voltage Selection	2-1
2-10.	Power Cable	2-2
2-12.	Interconnections	2-4
2-15.	5370B Listen Address.....	2-4
2-17.	HP-IB Description.....	2-6
2-19.	Bench Operation	2-6
2-21.	OPERATING ENVIRONMENT	2-6
2-22.	Operating and Storage Temperature	2-6
2-24.	Cooling System	2-6
2-26.	STORAGE AND SHIPMENT	2-6
2-27.	Environment	2-6
2-29.	Packaging	2-6
SECTION III - OPERATING AND PROGRAMMING.....		3-1
3-1.	INTRODUCTION	3-1
3-3.	OPERATING CHARACTERISTICS	3-1
3-5.	Frequency Mode.....	3-1
3-7.	Period Mode.....	3-1
3-9.	Time Interval Mode	3-1
3-11.	PANEL FEATURES	3-2
3-13.	OPERATOR'S CHECKS.....	3-2
3-15.	OPERATING INSTRUCTIONS	3-2
3-17.	External Arming/External Holdoff.....	3-3
3-26.	Power/Warm-Up	2-5
3-29.	PROGRAMMING	2-17
3-30.	Introduction	2-17

TABLE OF CONTENTS (Continued)

Section	Title	Page
SECTION IV PERFORMANCE TESTS		4-1
4-1.	INTRODUCTION	4-1
4-3.	EQUIPMENT REQUIRED.....	4-1
4-5.	CALIBRATION CYCLE	4-1
4-9.	HP-IB OPERATION VERIFICATION	4-1
4-11.	PERFORMANCE TEST	4-1
4-13.	TEST RECORD.....	4-1
SECTION V ADJUSTMENTS.....		5-1
5-1.	INTRODUCTION.....	5-1
5-5.	SAFETY CONSIDERATIONS.....	5-1
5-9.	EQUIPMENT REQUIRED.....	5-2
5-11.	ADJUSTMENT LOCATIONS.....	5-2
5-13.	Adjustment Procedure.....	5-2
5-15.	ASSEMBLY REMOVAL AND REPLACEMENT	5-2
SECTION VI REPLACEABLE PARTS		6-1
6-1.	INTRODUCTION	6-1
6-3.	REFERENCE DESIGNATIONS.....	6-1
6-5.	REPLACEABLE PARTS.....	6-1
6-8.	HOW TO ORDER A PART	6-1
6-10.	Parts Identification	6-1
6-14.	Contacting Hewlett-Packard	6-2
6-18.	CABINET PARTS AND HARDWARE:	6-2
SECTION VII MANUAL CHANGES.....		7-1
7-1.	INTRODUCTION	7-1
7-3.	Older Instruments	7-1
7-5.	Newer Instruments.....	7-1
7-7.	MANUAL CHANGES	7-1
8-90.	A1, A6, Power Supply Motherboard/Power Supply Control Assembly	7-2
8-143.	A6 Power Supply	7-2
SECTION VIII SERVICE		8-1
8-1.	INTRODUCTION.....	8-1
8-3.	THEORY OF OPERATION.....	8-2
8-5.	TROUBLESHOOTING.....	8-2
8-7.	RECOMMENDED TEST EQUIPMENT.....	8-2
8-9.	SCHEMATIC DIAGRAM NOTES.....	8-2
8-11.	Reference Designations	8-2
8-13.	Identification Markings on Printed Circuit Boards	8-2
8-16.	SAFETY CONSIDERATIONS.....	8-4
8-20.	SERVICE ACCESSORY KIT 10870A.....	8-4
8-22.	Equipment Supplied.....	8-5
8-24.	Replaceable Parts	8-6
8-26.	Using Extender Board 05370-60075	8-6
8-28.	Theory of Operation (05370-60014)	8-7
8-33.	SIGNAL DESCRIPTIONS	8-8

TABLE OF CONTENTS (Continued)

Section	Title	Page
SECTION VIII SERVICE (CONTINUED)		8-1
8-35.	CABLES	8-15
8-37.	LOGIC SYMBOLS	8-15
8-60.	REPLACING FRONT PANEL LIGHTS	8-16
8-62.	Seven-Segment Display and Annunciator LEDs	8-16
8-65.	Push-button Switch and Clock Loss LEDs	8-16
8-71.	Trigger Light LEDs	8-17
8-73.	PUSH-BUTTON SWITCH REMOVAL	8-17
8-75.	BLOCK DIAGRAM THEORY	8-18
8-76.	Introduction	8-18
8-80.	Interpolating Technique	8-19
8-84.	The Equation	8-19
8-86.	Typical Instrument Operation	8-19
8-90.	A1, A6 Power Supply Motherboard/Power Supply Control Assembly	8-21
8-93.	A3 and A4 Input Assemblies	8-21
8-95.	A5 HP-IB Connector Assembly	8-21
8-97.	A8 Reference frequency Buffer Assembly	8-21
8-99.	A9 Processor Assembly	8-21
8-103.	A11 Display Interface Assembly	8-22
8-105.	A15 HP-IB Interface Logic Assembly	8-22
8-107.	A16 Arming Interface Assembly	8-22
8-109.	A17 Count Chain Assembly	8-22
8-112.	A18 DAC/N0 Logic Assembly	8-23
8-116.	A19 and A20 Interpolator Assemblies	8-23
8-122.	A21 200 MHz Multiplier Assembly	8-24
8-124.	A22 Arming Assembly	8-24
8-128.	A23 Display/Control Panel Assembly	8-24
8-130.	A69 10 MHz Oscillator Assembly	8-24
8-132.	DETAILED THEORY	8-24
8-134.	A3 Input Amplifier	8-24
8-140.	A4 Interconnect Board Assembly	8-25
8-143.	A6 Power Supply	8-25
8-149.	A7 oven Oscillator Power Supply	8-26
8-151.	A8 Reference Frequency Buffer	8-26
8-157.	A9 Microprocessor	8-28
8-163.	A11 Display Interface	8-29
8-168.	A15 HP-IB Interface	8-30
8-188.	A16 Arming Interface	8-34
8-195.	A17 Count Chain	8-35
8-199.	A18 DAC/N0 Logic	8-35
8-206.	A19/A20 Interpolators	8-36
8-227.	A21 200 MHz Multiplier	8-41
8-233.	A22 Arming Assembly	8-42
8-243.	A23 Front Panel Display	8-44
8-247.	A69 10 MHz Oscillator (Oven)	8-44
8-249.	TROUBLESHOOTING	8-44
8-251.	MICROPROCESSOR ADDRESS MAPPING	8-45
8-253.	Setup Procedure for Mapping	8-45
8-255.	Common Map Patterns	8-48

TABLE OF CONTENTS (Continued)

Section	Title	Page
SECTION VIII SERVICE (CONTINUED)		8-1
8-257.	A3/A4 INPUT AMPLIFIER/INTERCONNECT BOARD TROUBLESHOOTING ...	8-53
	DC Voltage Checks:	8-53
	Signal Checks:	8-53
8-259.	A8 REFERENCE FREQUENCY BUFFER TROUBLESHOOTING	8-54
8-261.	A18 DAC/NO LOGIC TROUBLESHOOTING	8-65
	8-263. DAC Circuit Troubleshooting	8-65
	8-266. NO Logic State Troubleshooting for +T.I. Only Arming	8-65
	8-270. NO Logic Static Troubleshooting for +T.I. Arming	8-66
8-274.	A19/A20 START/STOP INTERPOLATOR TROUBLESHOOTING	8-67
8-277.	A21 200 MHZ MULTIPLIER TROUBLESHOOTING	8-72
8-279.	A23 FRONT PANEL TROUBLESHOOTING	8-75
	8-280. Digit LED Displays	8-75
	8-283. Push-button Switch LEDs	8-75
	8-286. Push-button Switches	8-75
	8-289. Annunciator LEDs	8-76

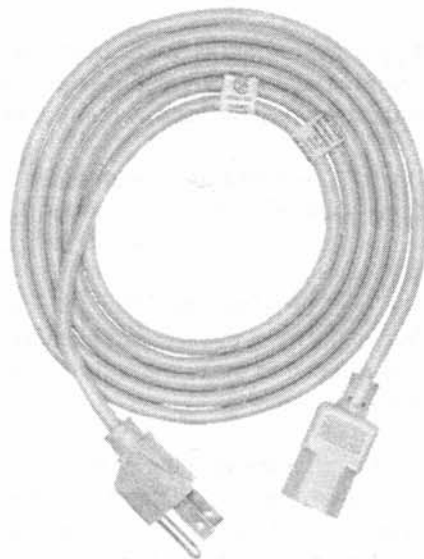

Figure 1-1. HP 5370B Universal Time Interval Counter and Accessories Supplied

SECTION I GENERAL INFORMATION

1-1. INTRODUCTION

1-2. This manual provides information about installation, operation, testing, adjustments, and servicing the Hewlett-Packard Model 5370B Universal Time Interval Counter. *Figure 1-1.* shows the 5370B with accessories supplied.

1-3. This manual has eight sections, each covering a particular topic for the operating and servicing the HP 5370B. The topics by section number are:

Section	Topic
I	General Information
II	Installation
III	Operating and Programming
IV	Performance Tests
V	Adjustments
VI	Replaceable Parts
VII	Manual Changes
VIII	Service

1-4. SPECIFICATIONS

1-5. The instrument specifications are listed in *Table 1-1.* These specifications are the performance standards or limits against which the instrument may be tested.

1-6. INSTRUMENTS COVERED BY MANUAL

1-7. If the serial number of your instrument is lower than the serial number on the title page of this manual, you must modify your manual for agreement with your instrument. Refer to Section VII, Manual Changes, for the information that will adapt this manual to your instrument.

1-8. The 5370B Options 908, 910, and 913 are documented in this manual. The differences are noted in the appropriate locations such as Options in Section I, and the Replaceable Parts List in Section VI.

1-9. This instrument has a two-part serial number. The first four digits and the letter comprise the serial number prefix. The last five digits form the sequential suffix that is unique to each instrument. The contents of this manual apply directly to instruments having the same serial number prefix(es) as listed under Serial Prefix on the title page.

1-10. An instrument manufactured after the printing of this manual may have a serial prefix that is not listed on the title page. This unlisted prefix indicates that the instrument is different from those documented in this manual. The manual for this instrument is supplied with a yellow Manual Changes supplement which contains change information that documents the difference.

1-11. In addition to change information, the supplement may contain information for correcting errors in the manual.

Table 1-1. HP 5370B Specifications *

INPUT AMPLIFIERS

SEPARATE INPUTS:

- Sensitivity:** 100 mV p-p, 35 mV rms sine wave times attenuator setting.
- Impedance:** Selectable 1 MΩ || <50 pF⁽¹⁾ or 50Ω **NOMINAL.**
- Trigger Level:** Adjustable from -2V to +2V with 10 mV displayed resolution.
- Trigger Slope:** Independent selection of + or - slope.
- Attenuators:** +1 and +10 **NOMINAL.**
- Dynamic Range (preset):**
 - 50Ω +1 100 mV to 4V p-p pulse
 - +10 1V to 7V p-p pulse
 - 1 MΩ +1 100 mV to 4V p-p pulse
 - +10 1V to 10V p-p pulse

Dynamic range for rms sine wave is one-third of the above values.
- Signal Operating Range:**
 - 50Ω +1 -4V to +4V
 - +10 -7V to 7V
 - 1 MΩ +1 -4V to +4V
 - +10 -25V to 10V.

Coupling: AC or DC, switchable.

Maximum Pulse Width: 5 ns

Maximum Input:

- 50Ω +1 ±7V DC
7V rms below 5 MHz
3.5V rms (+24 dBm) above 5 MHz
- +10 ±7V DC, 7V rms (+30 dBm)
- 1 MΩ +1 ±350 V DC
250V rms to 20 kHz decreasing to
3.5V rms above 5 MHz
- +10 ±350V
250V rms to 20 kHz decreasing to
35V rms above 5 MHz.

COMMON INPUT

All specifications are the same as for separate operation with the following differences:

Impedance: 1 MΩ becomes 500 kΩ shunted by <80 pF.
50Ω same as in separate.

Sensitivity (preset):

- 50Ω +1 200 mV p-p, 70 mV rms sine
- +10 2V p-p, 700 mV rms sine
- 1 MΩ Same as in separate

Dynamic Range (preset):

- 50Ω +1 200 mV to 5V p-p pulse
- +10 2V to 5V p-p pulse
- 1 MΩ Same as in separate

Maximum Input:

- 50Ω ±5V DC or 5 V rms
- 1 MΩ same as in separate

Attenuators: Becomes +2 and +20 for 50Ω, **NOMINAL.**

TIME INTERVAL MEASUREMENTS

TIME INTERVAL RANGE:

- ± **Mode:** -10 seconds to +10 seconds including 0 seconds.
- ± **Only Mode:** 10 ns to 10 seconds.
- Sample Size (N):** 1, 100, 1000, 10,000, 100,000
1 to 16777215 via HPIB
- Statistics:** Mean, Standard Deviation, Maximum, Minimum, Time between measurements ≈330 μs; minimum rise time 1 ns.
- Least Significant Digit Displayed:**

$$20 \text{ ps} / \sqrt{N}$$

Resolution (2):

$$\pm \frac{100 \text{ ps rms}}{\sqrt{N}} \pm \frac{\text{Start Trigger Error}}{\sqrt{N}} \pm \frac{\text{Stop Trigger Error}}{\sqrt{N}}$$

Accuracy (3): ± Resolution ± Time Base Error × Time Interval ± Trigger Level Timing Error ± 1 ns Systematic (4).

Differential Linearity: ±20

Trigger Error:

$$\frac{\sqrt{(150\mu\text{V})^2 + e_n^2}}{\text{Input voltage slew rate at trigger points (V/s)}} \text{ seconds rms}$$

Where 150 μV is the **TYPICAL** rms input amplifier noise on the 5370B and E_n is the rms noise of the input signal for a 500 MHz bandwidth.

FREQUENCY MEASUREMENTS

FREQUENCY RANGE: 0.1 Hz to 100 MHz

TIMED GATES:

Internal Gate Time: 1 period, 0.01, 0.1, 1 seconds

Least Significant Digit Displayed:

$$\frac{20\text{ps}}{\text{Gate Time}} \times \text{FREQ}$$

Resolution:

$$\pm \frac{100 \text{ ps rms}}{\text{Gate Time}} \times \text{FREQ} \pm 1.4 \frac{\text{Trigger Error}}{\text{Gate Time}} \times \text{FREQ}$$

Accuracy: ± Resolution ± (Time Base Error) × FREQ

$$\pm \frac{100 \text{ ps Systematic}}{\text{Gate Time}} \times \text{FREQ}$$

Statistics: Mean

SAMPLE MODE (single period):

Sample Size: Same as Time Interval

Least Significant Digit Displayed:

$$20\text{ps} / (\text{Gate Time} \times \sqrt{N}) \times \text{FREQ}$$

where Gate Time is the period of the input signal.

Statistics: Mean, Standard Deviation, Maximum, Minimum.

EXTERNAL GATE:

Gate Input: 20 ns to 10 seconds.

Resolution and accuracy estimates may be made with the same specification as Timed Gates above.

Table 1-1. HP 5370B Specifications *

PERIOD MEASUREMENTS

PERIOD RANGE: 10 ns to 10 seconds.

TIMED GATES:

Internal Gate Time: 1 period, 0.01, 0.1 1 seconds

Least Significant Digit Displayed:

$$\frac{20\text{ps}}{\text{Gate Time}} \times \text{PERIOD}$$

Resolution:

$$\pm \frac{100 \text{ ps rms}}{\text{Gate Time}} \times \text{PERIOD} \pm 1.4 \frac{\text{Trigger Error}}{\text{Gate Time}} \times \text{PERIOD}$$

Accuracy: \pm Resolution \pm Time Base Error \times PERIOD

$$\pm \frac{100 \text{ ps Systematic}}{\text{Gate Time}} \times \text{PERIOD}$$

SAMPLE MODE (single period):

Sample Size (N): Same as Time Interval.

Least Significant Digit Displayed: 20 ps/ \sqrt{N}

Resolution: $\pm 100 \text{ ps rms} / \sqrt{N} \pm 1.4 \text{ Trigger Error} / \sqrt{N}$

Accuracy: \pm Resolution \pm Time Base Error \times PERIOD $\pm 100 \text{ ps}$

Systematic

Statistics: Mean, Standard Deviation, Maximum, Minimum.

EXTERNAL GATE:

Gate Input: 20 ns to 10 seconds.

Resolution and Accuracy estimates may be made with the same specifications as timed measurements above.

GENERAL

EXTERNAL GATE

Input Impedance: 1 M Ω || 10 pF NOMINAL.

Slope: Selectable + or -

Level: Continuously adjustable -2V to +2V, preset 0V.

Sensitivity: 10 mV

Minimum Pulse Width: 20 ns

External Gate Range: 20 ns to 10 s/sample size

TRIGGER OUTPUTS (rear panel)

Start: Edge going from 0 to -0.7V **NOMINAL** into 50 Ω in sync with the opening of the start channel.

Stop: 0 to -0.7V edge into 50 Ω in sync with the closing of the stop channel.

FREQUENCY STANDARD INPUT (rear panel)

5 or 10 MHz >1.0V p-p into 1 k Ω . Maximum Input 10V.

FREQUENCY STANDARD OUTPUT (rear panel)

10 MHz

1V p-p into 50 Ω in sync with time base chosen (INT or EXT)

DISPLAY: 16 digits + sign, suppressed leading zeros.

DISPLAY RATE: 10 ms to 5 s or hold.

MINIMUM TIME BETWEEN MEASUREMENTS:

330 μ s

165 μ s (in the fast binary)

OPERATING TEMPERATURE: 0° to 50° C.

POWER REQUIREMENTS: 100, 120, 220, or 240 Vac +5% - 10%, 48 to 66 Hz, less than 250 VA.

DIMENSIONS: 425 mm (16-3/4 in) wide, 133mm (5-1/4 in) high, 457 mm (18 in) deep.

WEIGHT: 14.55 kg (32 lbs).

TIME BASE:

Crystal Frequency: 10 MHz

Stability:

Aging Rate:

- A. $< 5 \times 10^{-10}$ (s) per day after 24-hour warm-up when:
 1. oscillator off-time was less than 24 hours.
 2. Oscillator aging rate was $< 5 \times 10^{-10}$ per day prior to turn-off.
- B. $< 5 \times 10^{-10}$ (s) per day in less than 30 days of continuous operation for off-time greater than 24 hours.
- C. $< 1 \times 10^{-7}$ (s) per day for continuous operation.

Warm-up:

Within 5×10^{-9} of final value (see below) 10 minutes after turn-on when:

1. oscillator is operated in a 25°C environment with 20 Vdc Oven Supply voltage supplied.
2. oscillator off-time was less than 24 hours.
3. Oscillator aging rate was $< 5 \times 10^{-10}$ per day prior to turn-off.

Final value is defined as oscillator frequency 24 hours after turn-on.

Short Term: $< 1 \times 10^{-10}$ rms for 1 s average

Temperature: $< 7 \times 10^{-9}$ 0°C to 50° C.

Line Voltage: $< 1 \times 10^{-10}$ (s), $\pm 10\%$ from

NOMINAL.

(1) Use of 10013A (or equivalent) proves is recommended for time interval measurements in the 1M Ω position.

(2) Typically 35 ps rms.

(3) For precise time interval measurements, the input signal and trigger levels must comply with the following criteria in order to remain in the linear operating range of the input amplifiers: the peak input signal (V_S) must be at least 150 mV but not greater than 1.75V above or below the trigger voltage (V_{TL}), i.e.,

$$.15 \text{ V} < |V_S - V_{TL}| < 1.75 \text{ V}$$

(4) Typical systematic error ≈ 300 ps. With recommended warm-up time of 20 minutes and use of the SET REF feature, systematic error can be reduced to < 30 ps.

(5) 15 minutes after change.

* Specifications describe the instrument's warranted performance. Supplemental characteristics are intended to provide information useful in applying the instrument by giving **TYPICAL** or **NOMINAL**, but nonwarranted performance parameters.

1-12. For information concerning a serial number prefix not listed on the title page or in the Manual Changes supplement, contact your nearest Hewlett-Packard office.

1-13. HP-IB INTERFACING, AND PROGRAMMING INFORMATION

1-14. Section II of this manual contains instructions for interfacing Model 5370B with the HP-IB. A brief description of the sequence of events comprising the transfer of data by the HP-IB is provided in Section III, followed by programming information. Information concerning the design criteria of the bus is available in IEEE Standard 488-1975, titled "*IEEE Standard Digital Interface for Programmable Instrumentation*".

1-15. SAFETY CONSIDERATIONS

1-16. This product is a Safety Class I instrument (provided with a protective earth terminal). Safety information pertinent to the operation and servicing of this instrument is included in appropriate sections of this manual.

1-17. DESCRIPTION

1-18. The Hewlett-Packard Model 5370B Universal Time Interval (T.I.) Counter is capable of making single-shot T.I. measurements with ± 20 ps resolution. It uses a phase-locked vernier interpolating technique in which the interpolating oscillators are locked to the time base, thus retaining its basic accuracy at all times. The technique also allows positive, zero, and negative time interval measurements, and a resident microprocessor extends the usefulness of the instrument by offering statistical data such as mean, standard deviation, max, min, etc., for repetitive time intervals.

1-19. Other features include push-button user-defined time interval reference for systematic error cancellation; "hysteresis" in arming circuitry eliminates possible random fluctuations between + and - measurements in repetitive time intervals. In addition to time interval, high resolution frequency and period measurements can be made with gates from one period to 1 second. Both time and event information are provided for interrogating complex waveforms.

1-20. The HP 5370B has a sensitive high-speed input amplifier with digital trigger level set, and a precision quartz crystal oscillator for accurate long T.I. measurements.

1-21. OPTIONS

1-22. The following is a list of equipment and accessory options available with the 5370B.

Hardware Options

908	Rack Mount Flange Kit (for use without handles)
910	One Additional Manual
913	Rack Mount Flange Kit (for use with handles)

Support Options

W30	Three-year customer return repair coverage
W32	Three-year customer return calibration coverage
W34	Three-year customer return Standard Compliant Calibration Service
W50	Five-year customer return repair coverage
W52	Five-year customer return calibration coverage
W54	Five-year customer return Standard Compliant Calibration service

Support options are available only at time of purchase. Service contracts are available from Hewlett-Packard for instruments which did not include support options at time of purchase. For information, contact your nearest Hewlett-Packard Sales and Support office (offices are listed at the back of this manual)

1-23. For more information concerning these options, contact your local Hewlett-Packard Sales and Support Office. A list of HP Sales and Support offices is provided at the end of this manual.

1-24. ACCESSORIES SUPPLIED

1-25. The HP 5370B is supplied with a power cord (HP Part Number 8120-1378) as shown in *Figure 1-1*.

1-26. EQUIPMENT AVAILABLE

1-27. A service accessory kit for the HP 5370B is available for convenience of troubleshooting and repairing the instrument. The service accessory kit contains extender boards and a service aid board. The accessory kit may be obtained from Hewlett-Packard by ordering Service Accessory Kit part number 10870A.

1-28. RECOMMENDED TEST EQUIPMENT

1-29. Equipment required to maintain the HP 5370B is listed in *Table 1-2*. Other equipment can be substituted if it meets or exceeds the critical specifications listed in the table.

Table 1-2. Recommended Test Equipment

Instrument	Critical Specifications	Recommended Model	Use
Service Kit Consists of:			A, T
Service Board	No Substitute	05370-60014	T
Extender Board	30 Pin X2	5060-0049	T
Extender Board	22 Pin X2	5060-0630	T
Extender Board	For A22 Arming (No Substitute)	05370-60074	T
Extender Board	For A7 Oscillator Power Supply (6 Pin X2)	05370-60076	T
Extender Board	For Digital Section (A9 through A17)	05370-60075	T
Extender Board	For 5359A Use	05359-60078	T
Extender Board	For Analog Section (A18 through A21)	05370-60077	T
Time Synthesizer	<20 ns Rise Time	5359A	P
Pulse Generator	<5 ns Rise Time	8082A	A
Frequency Synthesizer/ Function Generator	0.1 Hz to 1 MHz	3325A	P
Signal Generator	100 MHz Signal	8640B	A
Frequency Synthesizer	10 MHz to 100 MHz	8656B	P
Oscilloscope	200 MHz	1725A	A, T
Sampling Oscilloscope	1 GHz Bandwidth	182C	A
Sampling Plug-In		1810A	A
Spectrum Analyzer	200 MHz Center Frequency with >100 MHz Bandwidth	141T/8552A/8554L	A
Active Probe		1120A	A, T
Probe P.S.		1122A	A, T
Signature Analyzer	No Substitute	5005A/5006A	T
DMM	3½ Digit with 0.1% Accuracy	3435A	A, T
Controller	No Substitute	9825A	P, T
Logic Probe		545A	T
Pulser		546A	T
Current Tracer		547A	T
Cables (7)	4' BNC 50Ω Cables (2 matched length with 1/2-in)	11170C	P,A,T
Tuning Wand	Ceramic	8730-0013	A
Tuning Wand	Long Plastic	8730-0011	A

*P = Performance Tests, A = Adjustments, T = Troubleshooting

SECTION II INSTALLATION

2-1. INTRODUCTION

2-2. This section provides all information necessary to install the HP 5370B. Covered in this section are initial inspection, power requirements, line voltage selection, interconnection, mounting, storage, and repackaging for shipment.

2-3. INITIAL INSPECTION

2-4. Inspect the shipping container for damage. If the shipping container or cushioning material is damaged, it should be kept until the contents of the shipment have been checked for completeness and the shipment has been checked mechanically and electrically. The contents of the shipment should be as shown in *Figure 1-1*. If the contents are incomplete, if there is mechanical damage or defect, or if the instrument does not pass the electrical performance test, notify the nearest Hewlett-Packard office. Procedures for checking electrical performance are given in Section IV. If the shipping container is damaged, or the cushioning material shows signs of stress, notify the carrier as well as the Hewlett-Packard office. Keep the shipping material for the carrier's inspection.

2-5. PREPARATION FOR USE

2-6. Power Requirements

2-7. The HP 5370B requires a power source of 100, 120, 220, or 240V ac, +5%, -10%, 48 to 66 Hz single phase. Power consumption is approximately 200 watts nominal.

WARNING

IF THIS INSTRUMENT IS TO BE ENERGIZED VIA AN AUTOTRANSFORMER FOR VOLTAGE REDUCTION, MAKE SURE THE COMMON TERMINAL IS CONNECTED TO THE EARTHED POLE OF THE POWER SOURCE.

2-8. Line Voltage Selection

CAUTION

BEFORE SWITCHING ON THIS INSTRUMENT, make sure the instrument is set to the voltage of the power source.

2-9. Figure 2-1 provides instructions for the line voltage and fuse selection. The line voltage selection card and the proper fuse are factory installed for 120V ac operation.

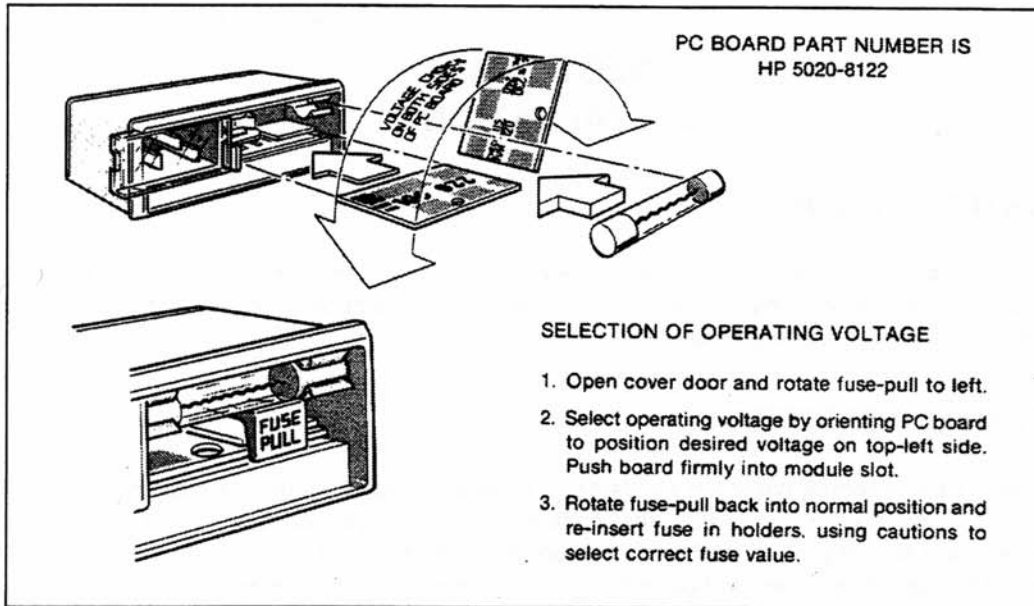

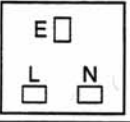

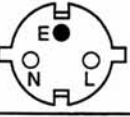

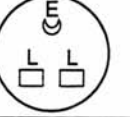

Figure 2-1. Line Voltage Selection

2-10. Power Cable

WARNING

BEFORE SWITCHING ON THIS INSTRUMENT, THE PROTECTIVE EARTH TERMINALS OF THIS INSTRUMENT MUST BE CONNECTED TO THE PROTECTIVE CONDUCTOR OF THE (MAINS) POWER CORD. THE MAINS PLUG SHALL ONLY BE INSERTED IN A SOCKET OUTLET PROVIDED WITH A PROTECTIVE EARTH CONTACT. THE PROTECTIVE ACTION MUST NOT BE NEGATED BY THE USE OF AN EXTENSION CORD (POWER CABLE) WITHOUT A PROTECTIVE CONDUCTOR (GROUNDING).

2-11. The 5370B is shipped with a three-wire power cable. When the cable is connected to an appropriate ac power source, this cable connects the chassis to earth ground. The type of power cable plug shipped with each instrument depends on the country of destination. Refer to Figure 2-2 for the part numbers of the power cable and plug configurations available.

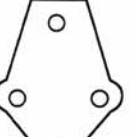
Plug Type	Cable HP Part No.	*C D	Plug Description	Cable Length (Inches)	Cable Color	For Use In Country
250V 	8120-1351	0 6	Straight **BS1363A 90°	90 90	Mint Gray Mint Gray	United Kingdom, Cyprus, Nigeria, Zimbabwe, Singapore
250V 	8120-1369 8120-0696	0	Straight NZSS198/ASC112 90°	70 87	Gray Gray	Australia, New Zealand
250V 	8120-1689 8120-1692	7 2	Straight **CEE7-Y11 90°	79 79	Mint Gray Mint Gray	East and West Europe, Egypt, (Unpolarized in many nations)
125V 	8120-1348 8120-1389 8120-1754 8120-1378 8120-1521 8120-1676 8120-4753	5 5 7 1 6 1	Straight **NEMA5-15P 90° Straight **NEMA5-15P Straight **NEMA5-15P 90° Straight **NEMA5-15P Straight **NEMA5-15P	80 80 36 80 80 30 90	Black Black Black Jade Gray Jade Gray Jade Gray Dark Gray	United States, Canada, 100V or 200V, Mexico, Philippines, Taiwan, Saudi Arabia, Japan
250V 	8120-2104	3	Straight **SEV1011 1959-24507	79	Gray	Switzerland
250V 	8120-0698	6	Straight **NEMA6-15P			United States, Canada
220V 	8120-2956 8120-2957	2 3	Straight **DHCK 107 90°	79 79	Gray Gray	Denmark
220V 	8120-4211 8120-4600		Straight 90°		Gray Gray	South Africa, India

*CD = Check Digit (refer to Replaceable Parts in Service Manual).

**Part number shown for plug is industry identifier for plug only. Number shown for cable is HP Part Number for complete cable including plug.

E = Earth Ground L = Line N = Neutral

Figure 2-2. Power Cable HP Part Numbers versus Mains Plugs Available

2-12. Interconnections

2-13. HEWLETT-PACKARD INTERFACE BUS. Interconnection data concerning the rear panel HP-IB connector is provided in *Figure 2-3*. This connector is compatible with the HP 10631A/B/ C/D HP-IB Cables. With the HP-IB system, you can interconnect up to 15 (including the controller) HP-IB compatible instruments. The HP-IB cables have identical "piggyback" connectors on both ends so several cables can be connected to a single source without special adapters or switch boxes. You can interconnect system components and devices in virtually any configuration you desire. There must, of course, be a path from the calculator (or other controller) to every device operating on the bus. As a practical matter, avoid stacking more than three or four cables on any one connector. If the stack gets too large, the force on the stack produces leverage which can damage the connector mounting. Be sure each connector is firmly screwed in place to keep it from working loose during use.

2-14. CABLE LENGTH RESTRICTIONS. To achieve design performance with the HP-IB, proper voltage levels and timing relationships must be maintained. If the system cable is too long, the lines cannot be driven properly and the system will fail to perform properly. Therefore, when interconnecting an HP-IB system, it is important to observe the following rules:

- a. The total cable length for the system must be less than or equal to 20 meters (65 feet).
- b. The total cable length for the system must be equal to or less than 2 meters (6.6 feet) times the total number of devices connected to the bus.
- c. The total number of instruments connected to the bus must not exceed 15.

2-15. 5370B Listen Address

2-16. The 5370B contains a rear panel HP-IB Instrument ADDRESS SELECTION switch. There are five switches designated (5, 4, 3, 2, 1) which are used to select the address. Instructions for setting and changing the listen address are provided in Section III of this manual along with 5370B programming codes.

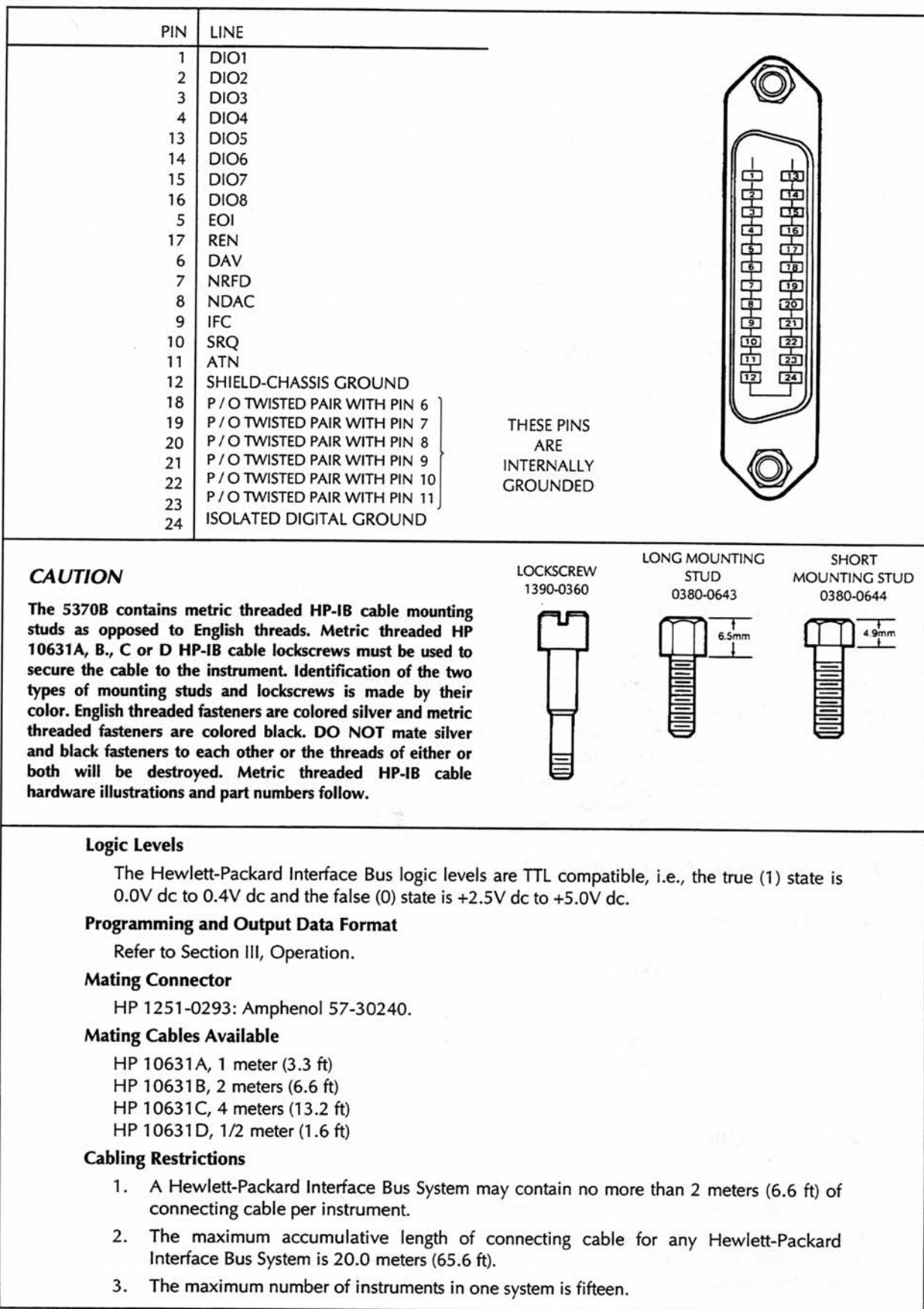

Figure 2-3. Hewlett-Packard Interface Bus Connection

2-17. HP-IB Description

2-18. A description of the HP-IB is provided in Section III of this manual. A study of this information is necessary if you are not familiar with the HP-IB concept. Additional information concerning the design criteria and operation of the bus is available in IEEE Standard 488-1975, titled "IEEE Standard Digital Interface for Programmable Instrumentation".

2-19. Bench Operation

2-20. The instrument has plastic feet and a fold-away tilt stand for convenience in bench operation. The tilt stand raises the front of the instrument for easier viewing of the control panel. The plastic feet are shaped to make full width modular instruments self-aligning when stacked.

2-21. OPERATING ENVIRONMENT

2-22. Operating and Storage Temperature

2-23. In order for the 5370B to meet the specifications listed in *Table 1-1*, the operating environment must be within the following limits:

Temperature	0° to +50° C
Humidity	<80% relative
Altitude	<15,000 feet

2-24. Cooling System

2-25. A forced air cooling system is used to maintain the operating temperature required by the instrument. The cooling fan is located on the left-side of the rear panel (while looking at the rear panel). When operating the 5370B, choose a location that provides at least 8 cm (3 inches) of clearance at the rear and at least 2 cm (1 inch) for each side. Failure to provide adequate air clearance will result in excessive temperature reducing instrument reliability. The clearances provided by the plastic feet in bench stacking and the filler strip in rack mounting allow air passage across the top and bottom cabinet surfaces.

2-26. STORAGE AND SHIPMENT

2-27. Environment

2-28. The instrument should be stored in a clean, dry environment. The following environmental limitations apply to both storage and shipment:

Temperature	-40°C to +75°C
Humidity	<95% relative
Altitude	<50,000 feet

2-29. Packaging

2-30. ORIGINAL PACKAGING. Containers and materials equivalent to those used in factory packaging are available through Hewlett-Packard offices. If the instrument is being returned to Hewlett-Packard for servicing, attach a tag indicating the type of service required, return address, model number, and full serial number. Also, mark the container FRAGILE to assure careful handling. In any correspondence, refer to the instrument by model number and full serial number.

2-31. OTHER PACKAGING. The following general instructions should be used for repackaging with commercially available materials.

- a. Wrap the instrument in heavy paper or plastic. (If shipping to a Hewlett-Packard office or service center, attach a tag indicating the type of service required, return address, model number, and full serial number.)
- b. Use a strong shipping container. A double-wall carton made of 250-pound test material is adequate.
- c. Use enough shock-absorbing material (3- to 4-inch layer) around all sides of the instrument to provide firm cushion and prevent movement inside the container. Protect the control panel with cardboard.
- d. Seal the shipping container securely.
- e. Mark the shipping container FRAGILE to assure careful handling.

SECTION III OPERATING AND PROGRAMMING

3-1. INTRODUCTION

3-2. This section provides complete operating and programming information needed for the HP 5370B Universal Time Interval Counter. This section includes a description of all front and rear panel controls, connectors and indicators, operator's check, operating instructions both manually and remotely, and operator's maintenance.

3-3. OPERATING CHARACTERISTICS

3-4. The following paragraphs describe the operating ranges, resolution, and accuracy for Frequency, Period, and Time Interval modes.

3-5. Frequency Mode

3-6. All frequency measurements are made through the STOP channel input. The frequency range is 0.1 Hz to 100 MHz with a minimum input level of 100 mV p-p, or 35 mV rms sine wave times attenuator setting. The 5370B has 12 digits resolution with a 1-second measurement time. The accuracy is described using the following formula:

$$\text{Accuracy} = \pm \text{Resolution} \pm (\text{Time Base Error}) \times \text{Frequency} \pm \frac{100 \text{ ps rms Systematic}}{\text{gate time}} \times \text{Frequency}$$

3-7. Period Mode

3-8. The 5370B makes period measurements from 10 nanoseconds to 10 seconds with a minimum input signal level of 100 mV p-p, or 35 mV rms sine wave times the attenuator setting. All period measurements are made through the STOP channel input jack. The 5370B gives 12 digits resolution using a 1-second measurement (gate time). The resolution is described using the following formula:

$$\text{Resolution} = \pm \frac{100 \text{ ps}}{\text{Gate Time}} \times \text{Period} \pm 1.4 \left(\frac{\text{Trigger Error}}{\text{Gate Time}} \right) \times \text{Period}$$

The accuracy is the same as for the frequency measurements as described in paragraph 3-6.

3-9. Time Interval Mode

3-10. The 5370B measures time from 10 nanoseconds to 10 seconds in +T.I. ONLY, and -10 seconds to +10 seconds in \pm T.I. The minimum input level for a two source T.I. measurement is 100 mV p-p times the attenuator setting. For a one source T.I. measurement, the input signal must be applied to the START channel, the START COM/SEP switch must be set to START COM, both attenuators and both input impedance switches must be set to the same values. (NOTE: The 5370B divides the amplitude of an input signal by two when 50 Ω input impedances are used in the START COM mode. Input trigger levels should be divided in half to compensate for the reduced signal level.) For one source T.I. measurements with 50 Ω input impedances, the minimum input level is 200 mV p-p times the attenuator setting. The 1 M Ω minimum input level is 100 mV p-p times the attenuator setting. The resolution is described using the following formula:

$$\text{Resolution} = \frac{\pm 20 \text{ ps}}{\sqrt{N}} \pm \frac{\text{Start Trigger Error}}{\sqrt{N}} \pm \frac{\text{Stop Trigger Error}}{\sqrt{N}}$$

$$\text{Accuracy} = \pm \text{Resolution} \pm \text{Time Base error} \times \text{Time Interval} \\ \pm \text{Trigger Level Timing Error} \pm 1 \text{ ns Systematic}$$

The accuracy is described using the following formula: Accuracy = jitter \pm 1 ns systematic \pm time base $\frac{\pm \text{trigger error}}{\sqrt{N}}$ where jitter equals 35 ps typical, trigger error equals $\frac{\pm 2 \times \text{noise peak voltage}}{\text{Signal Slope V}/\mu\text{s}}$ microseconds and N equals sample size.

NOTE:

To make accurate Time Interval measurements at 1 M Ω input impedance the following HP 10013A probe compensation procedure should be done.

1. Set the HP 1725A Oscilloscope input coupling to dc.
2. Set the HP 8082A Pulse Generator to obtain a square wave pulse that is 100 kHz, 3V p-p, and has a 1 ns transition time.
3. Connect the 10013A probe to the oscilloscope input and probe the output of the 8082A Pulse Generator. Observe the square wave on the 1725A Oscilloscope display.
4. Adjust the 10013A probe's compensation capacitor for the under compensation (observed from the display).
5. Connect the same 10013A probe to the HP 5370B. Probe the output of the 8082A and adjust the 5370B LEVEL pot until the trigger LED starts flashing. Now, adjust pot back until trigger LED just turns off.
6. Adjust the 10013A compensation capacitor on the probe until the trigger LED on the 5370B starts flashing again.

The 10013A probe is now correctly calibrated.

3-11. PANEL FEATURES

3-12. Front and rear panel features of the HP 5370B are described in *Figure 3-1* and *Figures-2*, respectively. These figures contain a description of the controls and connectors. Front panel indicators are described in *Figure 3-3*. Description numbers match the numbers on the illustrations.

3-13. OPERATOR'S CHECKS

3-14. A procedure for verifying the major functions of the HP 5370B is provided in *Figure 3-4*. The only accessory needed for the verification procedure is a 4-foot length coaxial BNC cable HP Part Number 10503A or equivalent and a 5 kHz oscilloscope.

3-15. OPERATING INSTRUCTIONS

WARNING

BEFORE THE INSTRUMENT IS SWITCHED ON, ALL PROTECTIVE EARTH TERMINALS, EXTENSION CORDS, AUTOTRANSFORMERS, AND DEVICES CONNECTED TO THE INSTRUMENT SHOULD BE CONNECTED TO A PROTECTIVE EARTH GROUNDED SOCKET. ANY INTERRUPTION OF THE PROTECTIVE EARTH GROUNDING WILL CAUSE A POTENTIAL SHOCK HAZARD THAT COULD RESULT IN PERSONAL INJURY.

ONLY FUSES WITH THE REQUIRED RATED CURRENT AND SPECIFIED TYPE SHOULD BE USED. DO NOT USE REPAIRED FUSES OR SHORT CIRCUITED FUSEHOLDERS. TO DO SO COULD CAUSE A SHOCK OR FIRE HAZARD.

CAUTION

BEFORE THE INSTRUMENT IS TURNED ON, it must be set to the voltage of the power source, or damage to the instrument could result.

3-16. Figures 3-5, 3-6, 3-7, and 3-8 show general operating procedures with the HP 5370B Universal Time Interval Counter connected in a typical measurement test setup. Many other applications are possible but not shown because the general operating procedure is the same. Description numbers match the group containing the particular designated switch.

3-17. External Arming/External Holdoff

3-18. The EXTERNAL Input jack (front panel) allows the 5370B to be externally armed and held off. The input works in conjunction with the EXT HOLDOFF, EXT ARM, and MAN INPUT switches. The specifications for the input signal are in Table 1-1.

3-19. EXTERNAL ARMING. To operate the counter in the EXTERNAL ARM mode, press the EXT ARM switch on the front panel. The selected trigger edge at the external input then arms the counter. The next START or STOP input pulse begins the measurement as illustrated in the diagram.

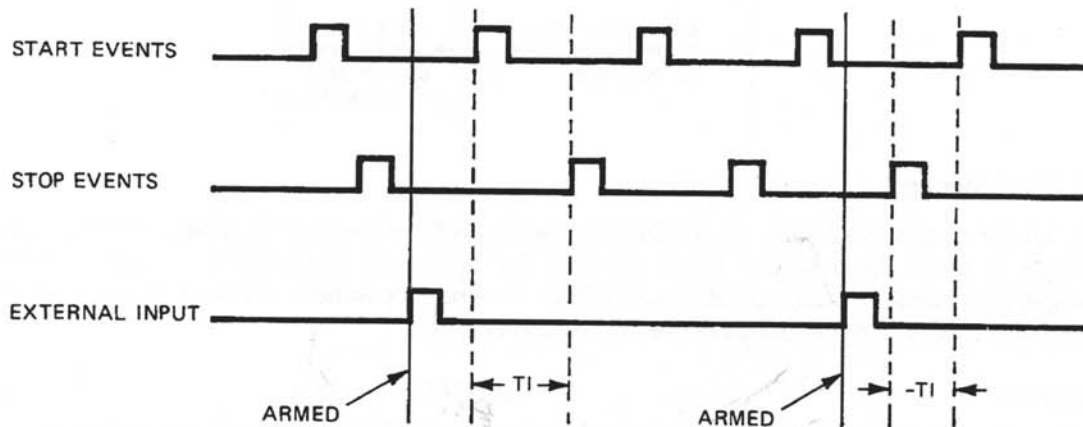

3-20. EXTERNAL ARM/ EXTERNAL HOLDOFF. To operate the counter in the EXTERNAL HOLDOFF mode, press the EXT HOLDOFF switch on the front panel. The selected trigger edge at the external input then arms the counter. The next START input pulse begins the measurement. The STOP pulses are held off as long as the external input holdoff is present as illustrated in the diagram.

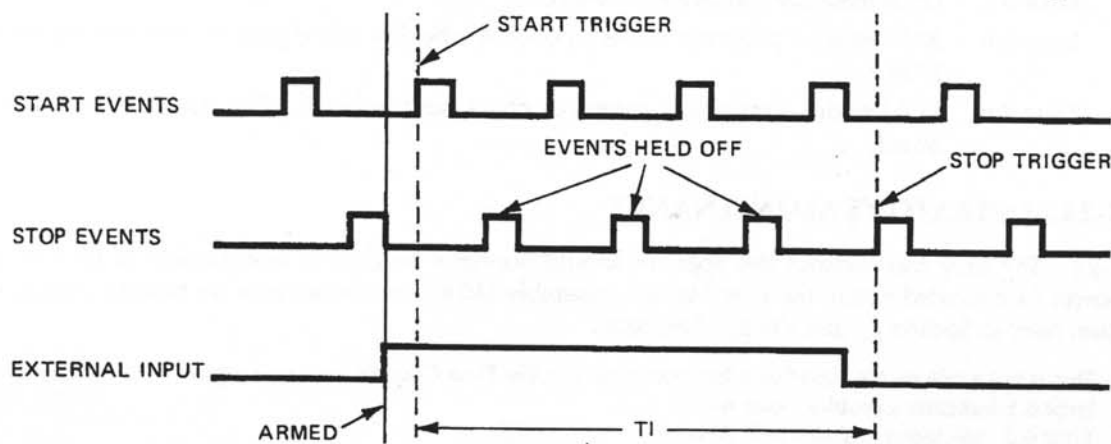

The number of events held off are counted and stored by the 5370B and can be displayed by pressing the DSP EVTS switch on the front panel.

3-21. EXTERNAL GATE. The 5370B may be operated in the External Gate mode for Frequency and Period measurements. To do this, press the EXT HOLDOFF switch on the front panel. The selected trigger edge at the external input then opens the main gate. The next edge then closes the gate. The following diagram illustrates the gate times for external gates with the 5370B front panel SLOPE switch set to *positive* and *negative*, respectively.

NOTE

Regardless of the length of the external gate, the 5370B displays 12 digits.

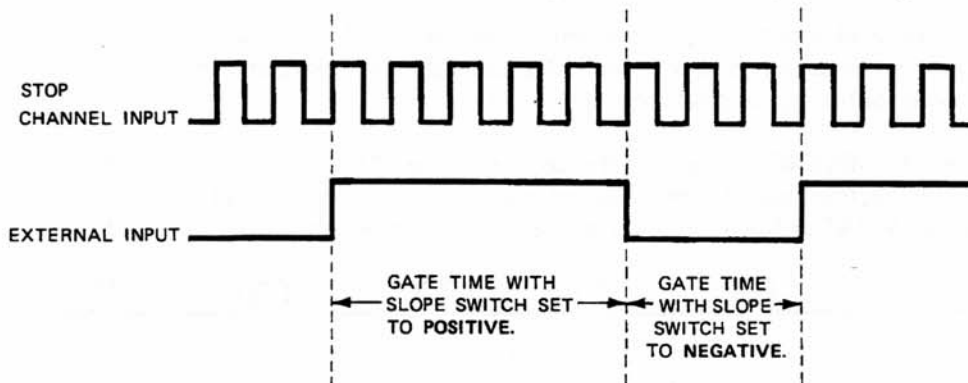

3-22. Error Messages

3-23. Under certain conditions, the 5370B will display an Error message (number). There are eight messages in all as listed below. Errors 6.n and 7.n pertain to power-up only. The remaining messages occur under certain operating conditions. In remote operation, the error message remains in the Status Byte until the initiation of the next measurement.

ERROR	MESSAGE
Error 0	A measurement has been completed and the 5370B has not yet been addressed.
Error 1	Indicates an illegal remote command or an undefined function (HP-IB) sent to 5370B.
Error 2	Data out of range (overrange). ¹
Error 3	Illegal key combination (local or HP-IB).
Error 4	Phase-locked loop out of lock.
Error 5	Undefined key (hardware problem).
Error 6.n	RAM error — processor writes into RAM (checker board pattern) and verifies error in RAM n. ²
Error 7.n	ROM error — processor computes check sum; error in ROM (U3) on A9 Processor board.

3-24. OPERATOR'S MAINTENANCE

3-25. The only maintenance the operator should normally perform is replacement of the primary power fuse located within the Line Module Assembly (A24). For instructions on how to change the fuse, refer to Section II, Line Voltage Selection.

¹ This is not a failure. No Stop Event has occurred, and the Time Counter has overrange.

² Error 6.1 indicates a problem with A9U1.

Error 6.2 indicates a problem with A9U8.

Error 6.3 indicates a problem with A9U5.

CAUTION

Make sure that only fuses with the required rated current and of the slow-blow type are used for replacement. The use of repaired fuses and the short-circuiting of fuse-holders must be avoided.

3-26. Power/Warm-Up

3-27. The HP 5370B requires a power source of 100, 120, 220, or 240 Vac, +5%, -10%, 48 to 66 Hz single phase. The selection of line voltage and input power fuse is described in Section II, paragraph 2-5, Preparation for Use.

3-28. The 5370B has a two-position power switch, STBY and ON. It is important that the instrument remain connected to the power source in the STBY mode when not in use. This supplies power to the crystal oven maintaining a constant oven temperature thus eliminating the need for a warm-up period. When the STBY mode is not used and power is disconnected from the instrument, allow 30 minutes from the application of external power in the ON mode for the instrument (crystal oven) to warm up.

WARNING

POWER IS ALWAYS PRESENT AT THE LINE SWITCH AND TRANSFORMER, AND UNREGULATED DC IS PRESENT WHENEVER THE LINE CORD IS ATTACHED. UNPLUGGING THE POWER CORD IS NECESSARY TO REMOVE ALL POWER FROM THE INSTRUMENT.

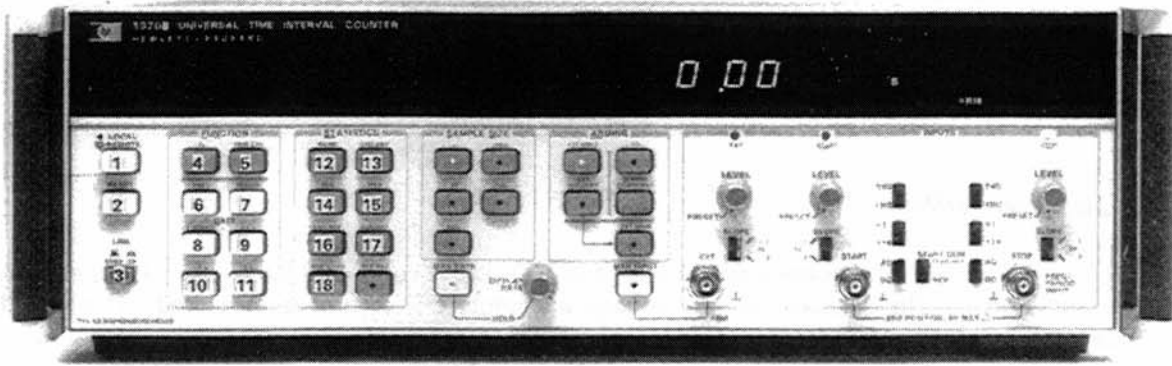

- | | | |
|---|---------------------|---|
| 1 | LOCAL REMOTE | Returns control from HP-IB to front panel. |
| 2 | RESET | Aborts current sample, performs lamp test, clears display, prepares machine to accept new samples and disarms instrument if manually armed. It does not destroy REFERENCE, EVENTS HOLDOFF, or the machine configuration. |
| 3 | STBY ON | Supplies power to entire machine in the ON position. Supplies power only to the oscillator oven in the STBY (standby) position. |
| 4 | T.I. | Time Interval function measures time differences from START channel to STOP channel. |
| 5 | TRIG LVL | Measures the voltage of the trigger levels of the START and STOP input channels and simultaneously displays them continuously. |
| 6 | FREQ | Measures frequency of the STOP channel signal by taking the reciprocal of a period average. START channel is ignored. |
| 7 | PERIOD | Measures a period average of STOP channel input events. START channel is ignored. Input amplifier control switch must be set to SEP. |
| 8 | 1 PERIOD | Measures one period of the input signal of the STOP channel and displays it as either frequency or period depending on the chosen function. 1 PERIOD is disabled when machine is in Time interval function. |
| NOTE: Gate Times 9, 10, and 11 are for frequency and period measurements only. | | |
| 9 | 0.01 s | Gate time of 0.01 second is enabled. |
| 10 | 0.1 s | Gate time of 0.1 second is enabled. |
| 11 | 1 s | Gate time of 1 second is enabled. |
| 12 | MEAN | Causes counter to measure and display the mean estimate which is the sample average from N time interval measurements minus a constant REFERENCE value. |
| 13 | STD DEV | Displays the standard deviation estimate for the selected sample size. |
| 14 | MIN | Displays the minimum time interval within the sample minus the REFERENCE. |
| 15 | MAX | Displays the maximum time interval within the sample minus the REFERENCE. |
| 16 | DSP REF | Displays the current value of REFERENCE stored. This value remains constant until changed by switch SET REF or by switch CLR REF. The power-up value of REFERENCE is zero. |
| 17 | CLR REF | Sets REFERENCE value to zero. |
| 18 | DSP EVTS | Displays the number of events input to the STOP channel which were held off during the sample measurement window. If HOLDOFF signal is not present, it displays the number of samples that have occurred per display cycle. |

Figure 3-1. Front Panel Controls, Indicators, and Connectors

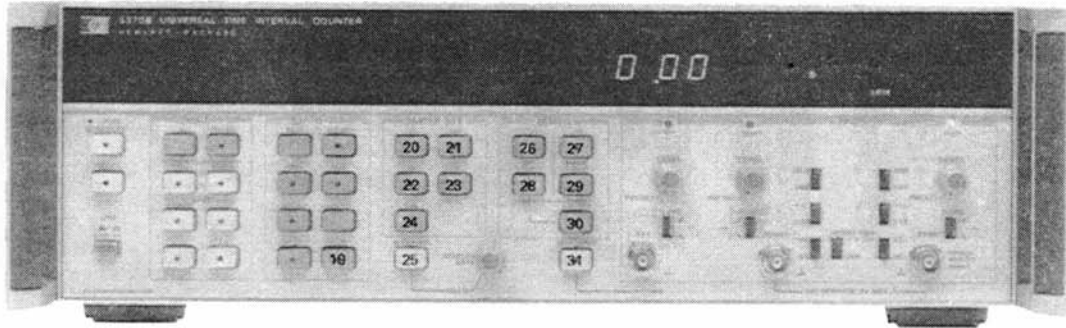

- 19 **SET REF** Establishes a new REFERENCE value equal to the average time interval of the latest sample.
- 20 **1** Instrument makes one measurement and displays result.
- 21 **100** Instrument makes one hundred measurements and displays result.
- 22 **1K** Instrument makes one thousand measurements and displays result.
- 23 **10K** Instrument makes ten thousand measurements and displays result.
- 24 **100K** Instrument makes one hundred thousand measurements and displays result.

NOTE

SAMPLE SIZE operates only with 1 PERIOD GATE. When gates other than 1 PERIOD are selected, SAMPLE SIZE is disabled. When a SAMPLE SIZE is selected, the 5370B automatically goes to 1 PERIOD mode.

- 25 **MAN RATE** Initiates a new sample for measurement when DISPLAY RATE control is in HOLD position. Old measurement value remains on display until replaced by new value. Also see DISPLAY RATE 32.
- 26 **+T.I. ONLY** In the +T.I. ONLY mode, all STOP channel events are ignored until the arrival of the START event. The counter is armed internally.
- 27 **± T.I.** In the ±T.I. mode, START event occurring before STOP event will automatically be assigned as a positive time interval and vice versa as a negative time interval. First incoming signal (either START or STOP) arms the counter.
- 28 **EXT HOLDOFF** Used in conjunction with EXT ARM mode switch; it enables the EXTERNAL HOLDOFF signal to inhibit STOP channel input signal.
- 29 **PERIOD COMPLMNT** In the ±T.I. mode, a T.I. measurement can be armed by the START or STOP channel using the PERIOD COMPLMNT switch. For repetitive signals, a T.I. measurement will switch from a +T.I. when armed on the STOP channel to a -T.I. when armed on the START channel. The selected arming channel is shown on the front panel display. Period Complement operates only in the ±T.I. mode. This switch has no effect when the instrument is externally armed, or when the T.I. is less than 10 nanoseconds.
- 30 **EXT ARM** In ±T.I. mode, the START and STOP channels are simultaneously armed after the arrival of the EXT input signal. As soon as the channels are armed, the time interval defined by the first event occurring in each channel is measured, regardless of the order of arrival. In +T.I. ONLY mode the START channel is armed after the arrival of the EXT input. Time Interval is defined by the first event in the START channel and the first event in the STOP channel arriving after the first event in the START channel.
- 31 **MAN INPUT** EXT INPUT signals for EXT ARM and/or EXT HOLDOFF functions can be generated manually through the MAN INPUT switch.

Figure 3-1. Front Panel Controls, Indicators, and Connectors

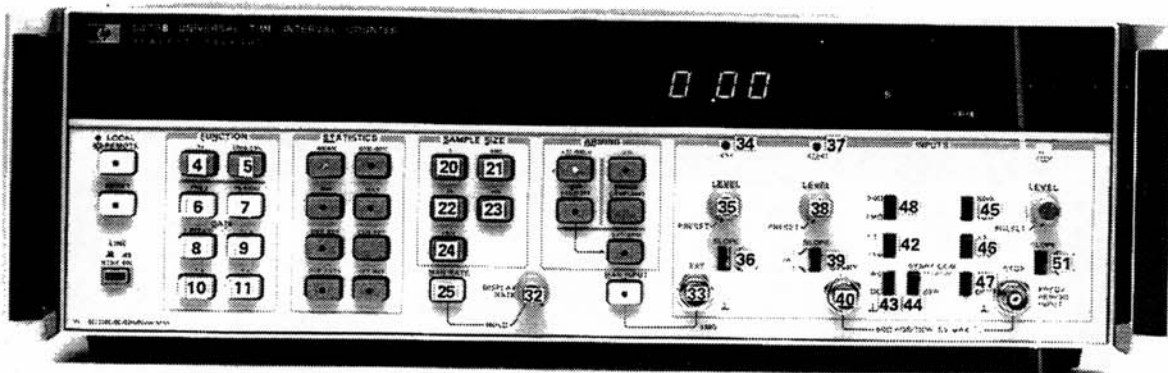

- 32 DISPLAY RATE** Determines time between sample measurements. Rotating this control more counter clockwise will add more time between measurements which in turn, displays previous measurements longer and gives a more stable display.
- When the DISPLAY RATE control is in the HOLD position, a new measurement can be initiated in several ways:
1. Pressing MAN RATE [25]
 2. Changing functions (4 through 7)
 3. Changing gate times (8 through 11)
 4. Changing sample size (20 through 24)
 5. Changing arming mode (\pm T.I. to +T.I. or reverse)
- 33 J1** Input BNC connector for the EXT HOLDOFF and/or EXT ARM signals with an input load impedance of 1 megohm. See *Table 1-1* for specifications.
- 34 EXT** LED indicator which when blinking, indicates that the external signal is triggering.
- 35 LEVEL** Trigger level control for the external input signal.
- 36 1 SE 2** This switch setting determines which slope of the external input signal will be used as the triggering slope.
- 37 49** LED indicators which when blinking, indicate that the START and/or STOP channel is triggering the machine.
- 38 50** LED indicators which when blinking, indicate that the START and/or STOP channel is triggering the machine.
- 39 1 SA 2** This switch setting determines which slope of the START channel input signal will be used as the triggering slope.
- 51 1 SO 2** This switch setting determines which slope of the STOP channel input signal will be used as the triggering slope.
- 40 48** Input BNC connectors for the START and STOP channel signal inputs.
- 41 45** Input impedance switches used to select an input impedance of 50 Ω or 1 Meg Ω shunted by less than 30 pF.
- 42 46** Selects attenuation for input signal. Used in conjunction with LEVEL control to set trigger point. Input level is not affected in +1 position. Input signal amplitude is reduced by a factor of 10 in +10 position.
- 43 47** Coupling switches used to select direct or capacitor coupling for input signal.
- 44** Input Amplifier Control switch.
- a. START COM - Operationally connects START and STOP channels in parallel. Used for single source time interval measurement. STOP channel jack is not active. START and STOP input impedance switches must be set to same position.
 - b. SEP - Allows independent operation of START and STOP channels.

Figure 3-1. Front Panel Controls, indicators, and Connectors (Continued)

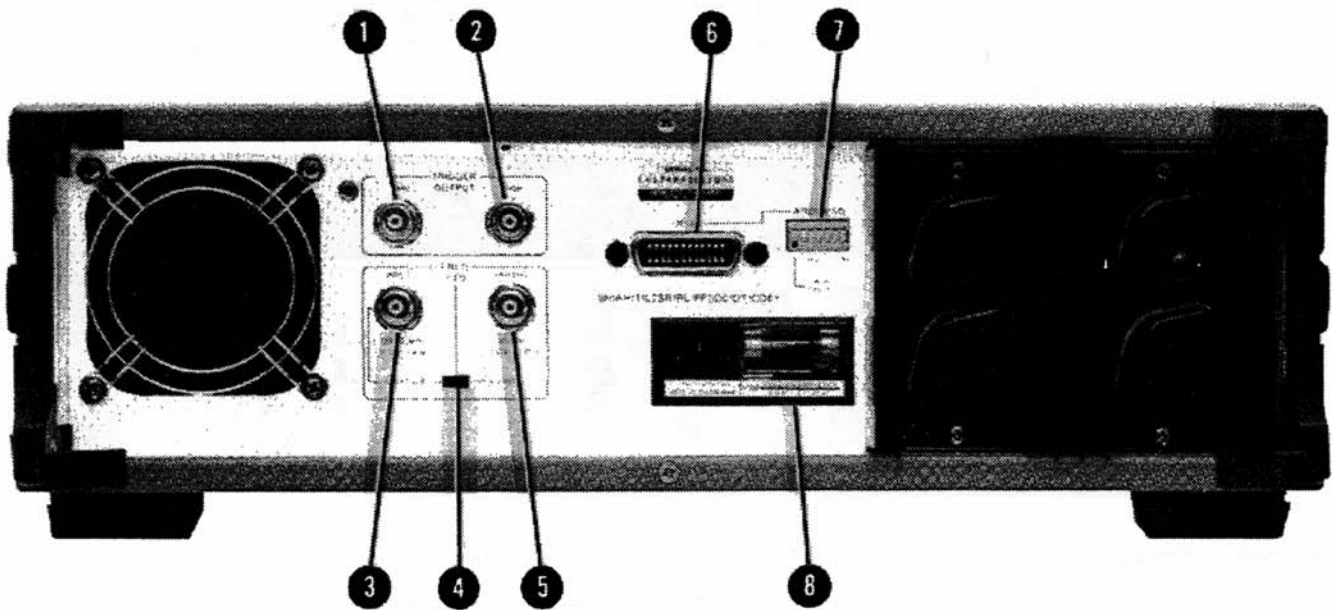

- 1 TRIGGER OUTPUT START jack. Edge going from 0 to -0.7 volt nominal into 50 Ω in sync with the opening of the START channel.
- 2 TRIGGER OUTPUT STOP jack. Edge going from 0 to -0.7 volt nominal into 50 Ω in sync with the closing of the STOP channel.
- 3 FREQ STD INPUT jack. Allows 5370B to be operated synchronous with an external standard of either 5 or 10 megahertz with drive of 1 volt rms across 1 kilohms. FREQ STD select switch 4 must be set to EXT position.
- 4 FREQ STD select switch.
 - a. INT allows the 5370B to operate with the internal time base standard.
 - b. EXT allows the 5370B to operate with an external time base standard.
- 5 FREQ STD OUTPUT jack. Provides 10 megahertz internal standard signal for external use. Amplitude is 1 volt rms into 50 ohms. FREQ STD select switch 4 set to INT position, provides output of the internal 10 MHz clock. EXT position provides a buffered output of the external time base standard being used.
- 6 Interface connector for 5370B connection to HP-IB remote interface.
- 7 ADDRESS switch cluster containing address switch A1 through A5 and TALK ONLY switch A7- Switch A6 is not internally connected. See programming in this section for detailed explanation.
- 8 AC power input module permits 5370B operation from 100, 120, 220, or 240 volts ac. The number visible in the window indicates nominal line voltage to which instrument must be connected (see *Figure 2-1*). Protective ground conductor connects to the instrument through this module.

WARNING

ANY INTERRUPTION OF THE PROTECTIVE (GROUNDING) CONDUCTOR INSIDE OR OUTSIDE THE INSTRUMENT OR DISCONNECTING OF THE PROTECTIVE EARTH TERMINAL IS LIKELY TO MAKE THE INSTRUMENT DANGEROUS. (SEE SECTION II.)

Figure 3-2. Rear Panel Features

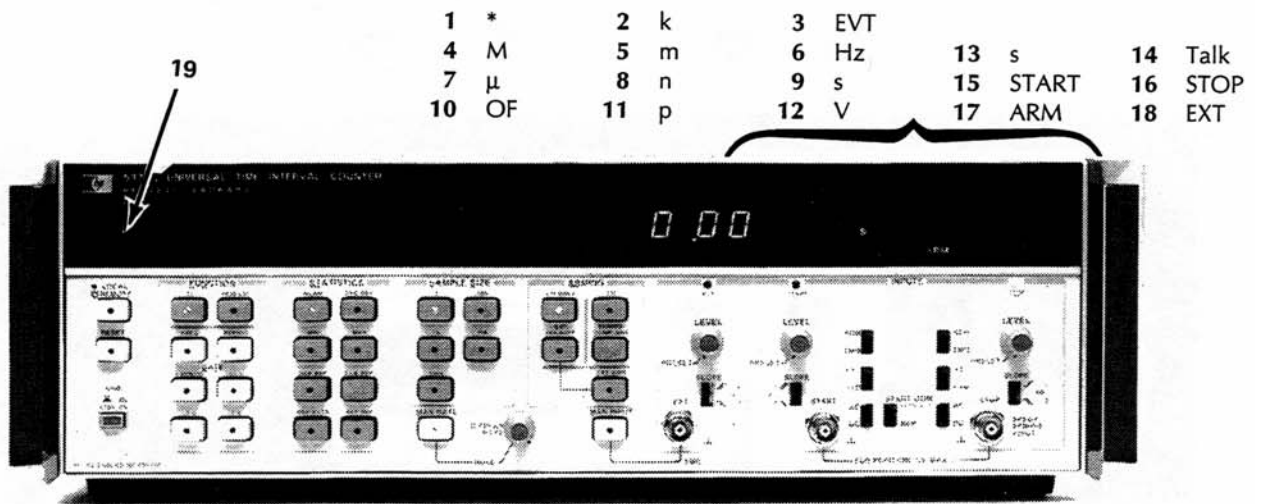

- | | | | | |
|---------|------|-------|----------|---------|
| 1 * | 2 k | 3 EVT | | |
| 4 M | 5 m | 6 Hz | 13 s | 14 Talk |
| 7 μ | 8 n | 9 s | 15 START | 16 STOP |
| 10 OF | 11 p | 12 V | 17 ARM | 18 EXT |

Number	Symbol	Description
1	*	<p>ASTERISK — Indicates crystal oscillator oven is below operating temperature (cold), as is the case when the 5370B is first plugged into the line supply.</p> <p>NOTE: The ASTERISK (*) was designed to only come on when the crystal oscillator oven is cold AND the unit is making a measurement. Otherwise, if the unit has been unplugged, and no measurement is being made, the ASTERISK LED will remain off.</p> <p>Pressing the RESET button will cause the ASTERISK to come on if the crystal oscillator is cold. It will remain on until the oven is at the normal operating temperature AND you press RESET again.</p>
2	k	kilo (10^3)
3	EVT	Events
4	M	Mega (10^6)
5	m	Milli (10^{-3})
6	Hz	Hertz
7	μ	Micro (10^{-6})
8	n	nano (10^{-9})
9	s	seconds
10	OF	overflow
11	P	pico (10^{-12})
12	V	volts
13	LSTN	Listen - Active when 5370B is programmed to listen.
14	TALK	Active when 5370B is programmed to talk.
15	START	Active when Time Interval measurement is armed by START channel signal input in the +T.I. mode.
16	STOP	Active when Time Interval measurement is armed by STOP channel signal input in the +T.I. mode.
17	ARM	Indicates 5370B is armed (ready to measure input signal). ARM light is actually flickering while measuring N samples but so fast as to appear to be continually on. ARM light may not appear lit for single samples of narrow events. Light stays on during measurement time.
18	EXT	Indicates machine is in the EXTERNAL ARM mode.
19		Oscillator clock loss indicator. Indicates loss of internal clock signal, possibly due to setting of rear panel FREQ STD switch. Once clock signal is returned, the 5370B power may need to be turned off and on again before internal circuits can operate properly.

Figure 3-3. Front Panel Display Indicators

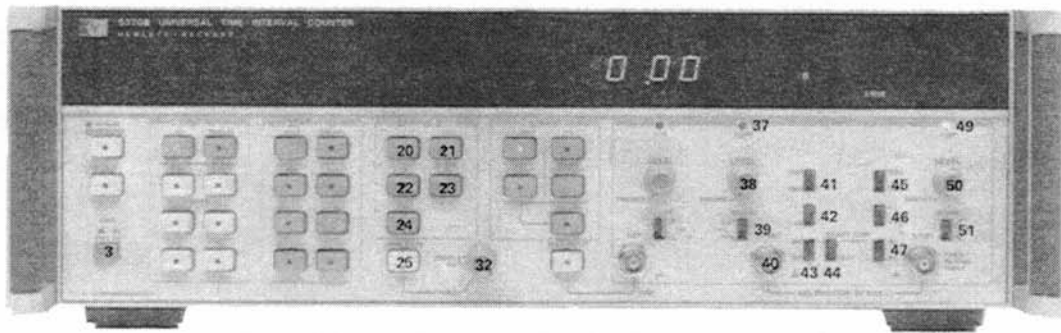

- 1 Before switching on the instrument, ensure that the power transformer primary is matched to the available line voltage, the correct fuse is installed, and the safety precautions are taken. See Power Requirements, Line Voltage Selection, Power Cables, and associated warnings and cautions in Section II of this manual. Description numbers match the numbers in *Figure 3-1* and *Figure 3-2*.
2. Connect a 4-foot BNC cable, such as HP 10503A, from the rear panel FREQ STD OUTPUT jack to the front panel START input jack 40.
3. Set the rear panel Frequency Select switch to INT.
4. Set the input impedance switches 41 45 to the 50 Ω position.
5. Set the attenuator switches 42 46 to the +1 position.
6. Set the AC, DC switches 43 47 to the DC position.
7. Set the input slope switches 39 51 to the 1 (positive going slope) position.
8. Set the LEVEL controls 38 50 to the preset position.
9. Set the COM, SEP switch 44 to the START COM position.
10. Adjust DISPLAY RATE 32 to maximum (full cw).
11. Press the LINE switch 3 to turn on the 5370B.

NOTE

When instrument is first turned on, the processor performs a self-check routine on the ROMs and RAMs. If, when power is first applied, or during operation, an error message is displayed, refer to paragraph 3-22 ERROR MESSAGES in this section for error explanation.

12. For the first second after the instrument is turned on, the display will remain blank. For the next second, all segments and decimal points and all annunciator lights (except START, STOP, and ARM) in the display will be lit as well as all LEDs in all the front panel switches.
13. After this initial power-up reset, the 5370B will be in the T.I. FUNCTION, MEAN STATISTICS, SAMPLE SIZE 1, and +T.I. ONLY. The display should indicate 100.00 nanoseconds ± 1.0 nanosecond with both the START and STOP channel trigger LEDs 37 49 flashing. Also, because of the sample size of one, the ARM light will not be visible in the display.
14. Press SAMPLE SIZE 100 switch 21. The least significant digit (LSD) will be one-digit greater (1 picosecond), the ARM light will be visible and flashing and the LED in the MAN RATE switch 25 will be flashing at approximately the same rate as the ARM light. Press SAMPLE SIZE 1K switch 22 and display will have same LSD (1 picosecond) with ARM light and MAN RATE switch flashing about twice per second. Press SAMPLE SIZE 10K 23 and display LSD will be 100 femtoseconds with ARM light flashing about once every four seconds. Press SAMPLE SIZE 100K switch 24 and the ARM light will flash about once every 40 seconds. Press SAMPLE SIZE 1 20.

Figure 3-4. Operators Checks

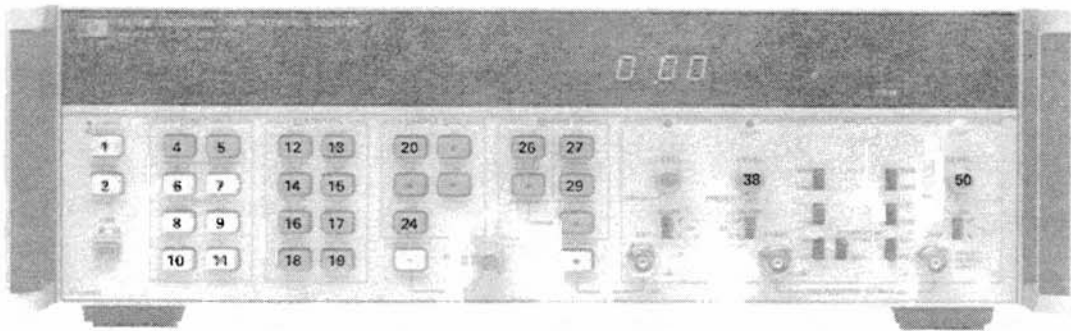

15. Press STD DEV 13 and +T.I. switch 27. Display should read less than 100 ps (this reading is the instrument's jitter). Notice that SAMPLE SIZE automatically goes to 100. For STD DEV measurements, SAMPLE SIZE must be ≥ 100 . Press MIN switch 14 and minimum T.I. should be displayed. Press MAX switch 15 and the maximum T.I. should be displayed. Press +T.I. ONLY 26 .
16. Press DSP REF switch 16 and three zeros should be displayed. Press SET REF switch 19 and approximately 100 nanoseconds should be displayed. This reference is the MEAN T.I. Press CLR REF switch 17 and six zeros should be displayed (if 99.99X ns is displayed, CLR REF will give five zeros), three zeros on either six of the decimal point. Press DSP EVTS switch 18 and 100 should be in the display. This number corresponds to the SAMPLE SIZE. Notice also EVT is displayed in the right hand side of the window.
17. Press MEAN switch 12 and SAMPLE SIZE 1 switch 20 . Press \pm T.I. switch 27 and the display should show less than 1 nanosecond. The STOP or START light in the display will also be on. Press PERIOD COMPLMNT switch 29 and the display should be the same except the other (STOP or START) light will be on in the display. Press the PERIOD COMPLMNT switch again and the first arming channel light should come back on. This switch operation is identical to a toggle switch.
18. Press TRIG LVL 5. There will be two groups displayed, three digits each, on the left and the right of the display. They indicate the DC trigger level voltage on the START and STOP channel inputs, respectively. Rotate the LEVEL controls 38 50 and note the voltage should change from approximately -2 to +2 volts. Turn both LEVEL controls fully counterclockwise until they click in the preset position. The display should show zero volts for both inputs.
19. Press FREQ switch 6. Press 0.01 s switch 9 and display should read approximately 10.000 000X MHz. Press 0.1 s switch 10 and display should read approximately 10.000 000 0X MHz. Press 1 s switch 11 and display should read approximately 10.000 000 0XX MHz. Press 1 PERIOD switch 8
20. Press PERIOD switch 7. Display should indicate approximately 100 nanoseconds.
21. Press Function switch T.I. 4 , 100K SAMPLE SIZE 24 , rotate DISPLAY RATE control maximum cw and check the rear panel START and STOP outputs 1 and 2 using an oscilloscope. Both signals should be $\geq -0.7V$ (into 50Ω) and approximately 320 μs wide as shown below.

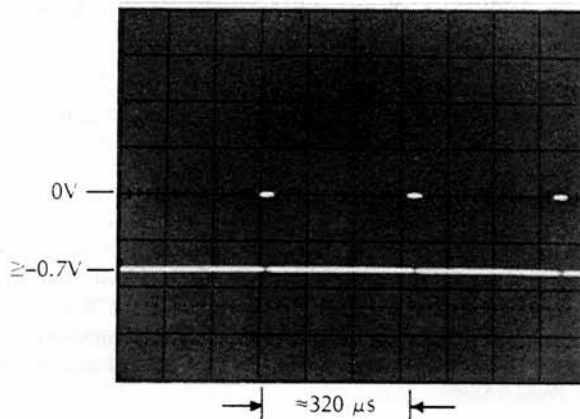
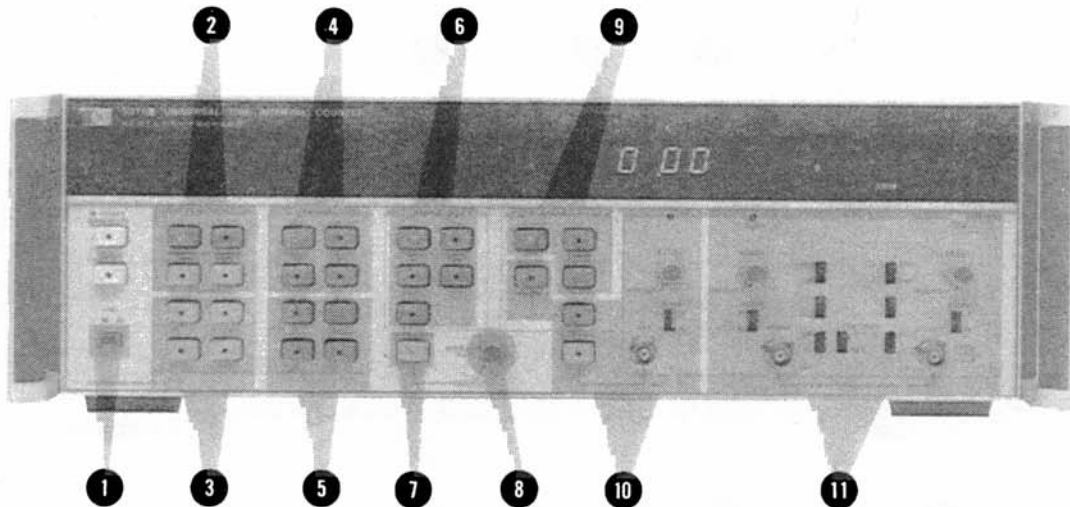

Figure 3-4. Operators Checks (Continued)



NOTE

See *Table 1-1* for specifications on all input signals concerning bandwidth, accuracy, and amplitude.

1. Set LINE switch **1** to ON position.

NOTE

All GATE switches are disabled when 5370B is in T.I. FUNCTION.

2. Set START and STOP input impedance, attenuation, and coupling switches to desired position; see specifications in *Table 1-1*.
3. Set START COM/SEP switch **11** to START COM position. When START COM/SEP switch is set to START COM, impedance switches must be set to the same impedance.
4. Connect input signal to START channel input jack.
5. Set START channel slope switch SA **11** to 1 for triggering on positive slope or to 2 for triggering on negative slope.
6. Set STOP channel slope switch SO **11** to 1 for triggering on positive slope or to 2 for triggering on negative slope.
7. Set START LEVEL control to start measurement at desired voltage level. Press TRIG LVL (trigger level) to display triggering voltage (if desired).
8. Set STOP LEVEL control to stop measurement at desired voltage level. Press T.I. FUNCTION.
9. Press desired STATISTICS **4**. When STD DEV is pressed in T.I. FUNCTION, the 5370B automatically goes to SAMPLE SIZE of 100 (unless SAMPLE SIZE is greater than 100). EXT HOLDOFF **10** and DSP EVT **5** will not operate when 5370B is set for \pm T.I. ARMING **9**.
10. Press desired SAMPLE SIZE **6**.
11. Press desired ARMING mode **9**. See *Table 1-1* for specifications on EXT input signal used for EXT HOLDOFF and/or EXT ARM.
12. Adjust DISPLAY RATE control **8** for a convenient interval between measurements.
13. If more than one piece of information is desired for a sample, turn DISPLAY RATE control **8** fully counterclockwise until it clicks in the HOLD position. Then press the MAN RATE (manual rate) switch **7** to start measurement. At the end, different statistical information for that one sample can be obtained by pressing the appropriate switches. Press **7** again for a new sample. For measurement of single-shot signal, set input conditioning as desired. Press T.I., MEAN, SAMPLE SIZE 1, EXT ARM MAN INPUT (or use external arming signal via EXT input) and DISPLAY RATE to HOLD. The instrument is now ready for the single-shot signal.

Figure 3-5. One Source Time Interval Measurement

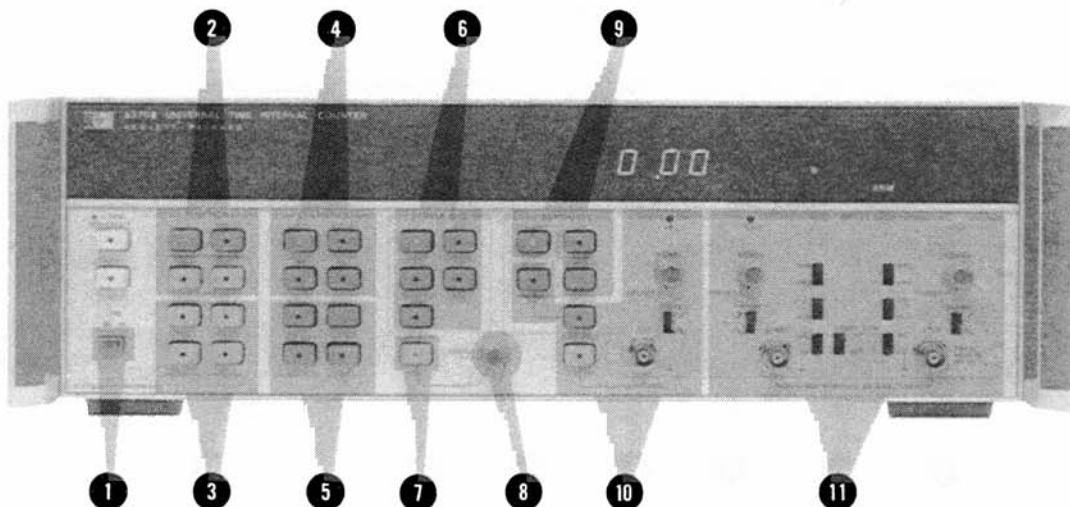

NOTE

See *Table 1-1* for specifications on all input signals concerning bandwidth, accuracy, and amplitude.

1. Set LINE SWITCH 1 to ON position.

NOTE

All GATE switches are disabled when the 5370B is in T.I. FUNCTION.

2. Set START and STOP input impedance, attenuation, and coupling switches 11 to desired position; see specifications in *Table 1-1*.
3. Set START COM/SEP switch 11 to SEP position.
4. Connect START signal to START input jack and STOP signal to STOP input jack.
5. Set START channel slope switch SA 11 to 1 for triggering on positive slope or to 2 for triggering on negative slope.
6. Set STOP channel slope switch SO 11 to 1 for triggering on positive slope or to 2 for triggering on negative slope.
7. Set START LEVEL control to start measurement at desired voltage level. Press TRIG LVL to display triggering voltage (if desired).
8. Set STOP LEVEL control to stop measurement at desired voltage level. Press T.I. FUNCTION.
9. Press desired STATISTICS 4. When STD DEV is pressed in T.I. FUNCTION, the 5370B automatically goes to SAMPLE SIZE of at least 100. EXT HOLDOFF (10) and DSP EXT 5 will not operate when 5370B is set for \pm T.I. ARMING 9 .
10. Press desired SAMPLE SIZE 6 .
11. Press desired ARMING mode 9 . See *Table 1-1* for specifications on EXT input signal used for EXT HOLDOFF and/or EXT ARM. See also paragraphs 3-17 through 3-21.
12. Adjust DISPLAY RATE control 8 for a convenient interval between measurement.
13. For one-shot measurements, see step 13 in *Figure 3-5*.

Figure 3-6. Two Source Time Interval Measurement

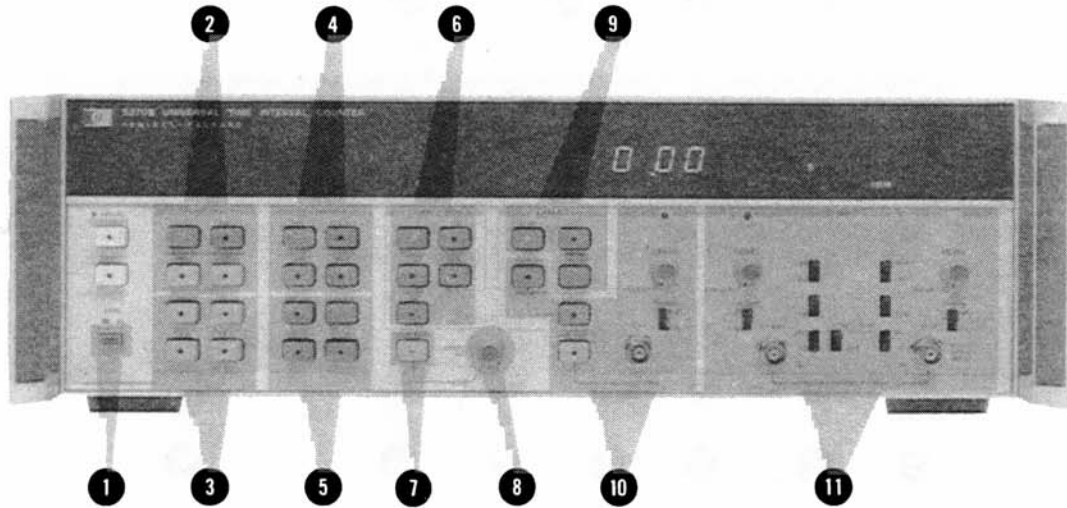

NOTE

See *Table 1-1* for specifications on all input signals concerning bandwidth, accuracy, and amplitude.

1. Set LINE switch **1** to ON position.
2. Set STOP LEVEL control to trigger measurement at desired voltage level. Press TRIG LVL **2** to display actual DC voltage of trigger level. Use PRESET for sine waves.
3. Set START COM/SEP switch **11** to SEP position.
4. Set STOP impedance, attenuation, and coupling switches **11** to desired position; see specifications in *Table 1-1* for details.
5. Connect input signal to STOP channel input jack **11**.
6. Press FREQ switch in FUNCTION group **2**.
7. Press GATE switch, group **3**, for desired integration time or press desired SAMPLE SIZE **6**.
8. Press desired STATISTICS switch **4**.
9. Adjust DISPLAY RATE control **8** for a convenient interval between measurements. If one-shot measurements are desired, see step 13 in *Figure 3-5*.

Figure 3-7. Frequency Measurements

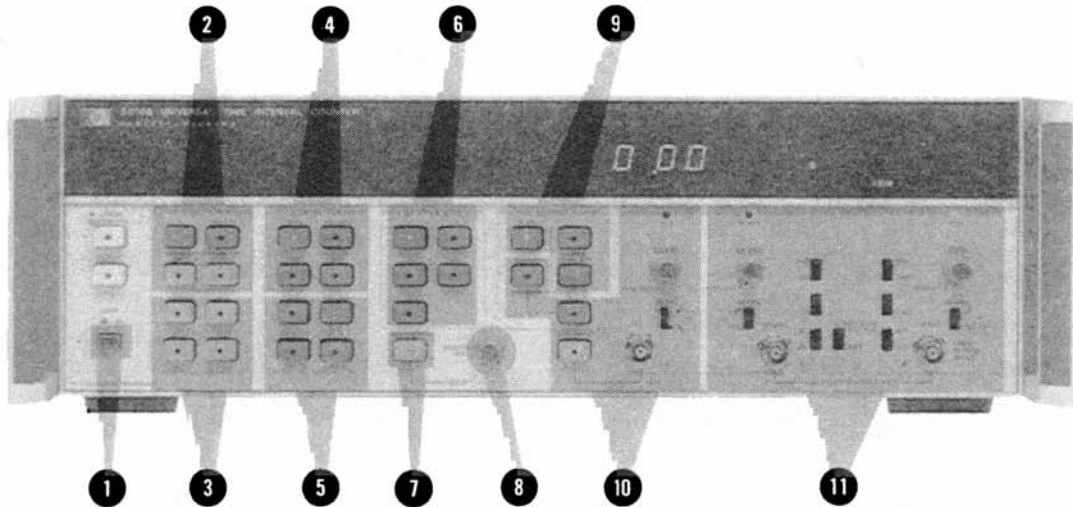

NOTE

See *Table 1-1* for specifications on all input signals concerning bandwidth, accuracy, and amplitude.

1. Set LINE switch **1** to ON position.
2. Press PERIOD switch in FUNCTION group **2**.
3. Set STOP impedance, attenuation, and coupling switches **11** to desired position; see specifications in *Table 1-1* for details.
4. Set STOP LEVEL control to trigger measurement at desired voltage level. Press TRIG LVL, group **2**, to display actual DC voltage of trigger level; press PERIOD again. Use PRESET for sine waves.
5. Set START COM/SEP switch **11** to SEP position.
6. Connect input signal to STOP channel input jack **11**.
7. Press desired SAMPLE SIZE switch **6** or GATE time switch **3**. If STD DEV (standard deviation) is to be displayed, SAMPLE SIZE must be >100.
8. Press desired STATISTICS switch **4**; statistics can only be performed while machine is in the 1 PERIOD **3** mode.
9. +T.I. is the only ARMING mode **9** usable in the PERIOD function.
10. Press desired switch for EXT ARM and/or EXT HOLDOFF **10**. See *Table 1-1* for specifications for External Gate input signal. See also paragraphs 3-17 through 3-21.
11. Adjust DISPLAY RATE control **8** for a convenient interval between measurements. If one-shot measurements are desired, see step 13 in *Figure 3-5*.

Figure 3-8. Period Measurements

3-29. PROGRAMMING

3-30. Introduction

3-31. The 5370B Universal Time Interval Counter is fully compatible with the Hewlett-Packard Interface Bus (HP-IB). The bus capability is installed as standard equipment and allows the counter or respond to remote control instructions and output measurement results via the HP-IB. At the simplest level, the 5370B can output data to other devices such as the 5150A Thermal Printer or the 59303A Digital-to-Analog Converter. In more sophisticated systems, a computing controller or other controllers can remotely program the 5370B to perform a specific type of measurement, trigger the measurement, and read the results.

NOTE

HP-IB is Hewlett-Packard's Implementation of IEEE Standard 4881975, "Standard Digital Interface for Programmable instrumentation".

3-32. This section describes how to use the HP 9825A and HP 9830A Calculators on the HP-IB bus as computing controllers to program the 5370B. Before starting to operate a system, it is helpful to be familiar with the selected calculator, the capabilities of the HP-IB, and the manual operation and capabilities of the 5370B. The following HP manuals provide useful background information:

- HP-IB Users Guide, 9830A (P/N 59300-90002)
- Hewlett-Packard 9825A Calculator General I/O Programming (P/N 09825-90024)
- Abbreviated Description of Hewlett-Packard Interface Bus (P/N 5955-2903)
- HP-IB Quick Reference (P/N 5955-2902)
- Hewlett-Packard 9825A Calculator Extended I/O Programming (09825-90025)

3-33. The capability of a device connected to the bus is specified by its interface functions. *Table 3-1* lists the 5370B Interface Functions using the terminology of the IEEE Std. 488-1975. These functions are also listed below the rear panel HP-IB connector. The number following the interface function code indicates the particular capability of that function as listed in Appendix C of IEEE Std. 488-1975. Interface functions provide the means for a device to receive, process, and send messages over the bus.

Table 3-1. HP-IB Interface Capability

CODE	INTERFACE FUNCTION
SH1	Source Handshake capability
AH1	Acceptor Handshake capability
T1	Talker (basic talker, serial poll, talk only mode)
L2	Listener (basic listener)
SR1	Service Request capability
RL1	Remote/Local capability
PP0	No Parallel Poll capability
DC1	Device Clear capability
DT1	Device Trigger capability
C0	No Controller capability
E1	One Unit Load

Table 3-2. Bus Message Usage

Message	Description	5370B Use	Sample 9825 Statements (5370B Set to Address 03)
Data	Transfers device-dependent information from one device to one or more devices on the bus.	Input: Accepts program codes. See Table 3-4 for program code set. Output: Sends measurement data. Output format is TI = SD.DDDDDDDDDDESDD	wrt 703,"SS3AR2" red 703,A
Trigger	Causes a group of selected devices to simultaneously initiate a set of device-dependent actions.	Starts a new measurement. Equivalent to the "MR" (manual rate) remote command.	trg 7 or trg 703
Clear	Causes an instrument to be set to a predefined state (a certain range, function, etc.).	Same as front panel RESET. Generates lamp test, clears status byte, followed by "MR. Does not set counter to predefined function.	clr 7 or clr 703
Remote	Permits selected devices to be set to remote operation, allowing parameters and device characteristics to be controlled by Bus Messages.	Causes counter to go to remote operation if REN is true and counter is addressed to listen. In absence of program data, remote operation is according to state of front panel settings just prior to going to remote. Locks out all pushbuttons except local (RTL).	rem 703
Local	Causes selected devices to return to local (front panel) operations.	Returns 5370B to front panel control.	lcl 703
Local Lockout	Disables local (front panel) controls for selected devices.	Disables local (RTL) push-button.	ll07
Clear Lockout and Local	Returns all devices to local (front panel) control and simultaneously clears the Local Lockout Message)	Returns counter to local (front panel) control and clears the local lockout message.	lcl7
Require Service	Indicates a device's need for interaction with the controller.	Used to flag an error condition or to indicate that measurement is complete. Error message is coded in status byte..	rds (703)→A
Status Byte	Presents status information of a particular device; one bit indicates whether or not the device currently requires service, the other 7 bits (optional) are used to indicate the type of service required.	Bit 8 is set if device is running debug monitor (diagnostic tool). Bit 7 is set if service is requested. Bit 6 is set if oven heater is on. Bit 5 is set if an external timebase is used. Bits 1-4 indicate error message if bit 7 is used. Error 0: Measurement is complete and counter is ready to output. Error 1: Illegal remote command. Error 2: Overrange (TI is too long or statistics overflow). Error 3: Undefined routine. Error 4: Out of lock (refers to internal phase lock loop). Error 5: Undefined key (indicates a hardware problem). Error 6: Fault in RAM storage. Error 7: Fault in ROM storage.	
Status Bit	A single bit of device-dependent status information which may be logically combined with status bit information from other devices by the controller.	Does not use.	
Pass Control	Passes bus controller responsibilities from the current controller to a device which can assume the Bus supervisory role.	Does not use.	
Abort	Unconditionally terminates Bus communications and returns control to the system controller.	Clears Talk, Listen, Serial Poll Enable registers on 5370B HP-IB Interface. Front panel setup does not change.	cli 7

3-34. Messages are the means by which devices exchange control and measurement information. These messages permit communication and/or control between: 1) controller and device(s); 2) device and device(s); and 3) controller and controller(s). *Table 3-2* lists the Bus Messages and gives a brief description of each.

3-35. Setting the Address Switches

3-36. To use the 5370B in an HP-IB system, the first step is to set the rear panel address switches as shown in *Table 3-3*. The leftmost switch sets the counter to the ADDRESSABLE mode or the TALK ONLY mode. ADDRESSABLE mode is used whenever a calculator or other controller is used within the system. TALK ONLY mode is used when the counter is operating under its own control (no controller on bus) and outputs its measured result to another device on the bus, such as a printer.

3-37. The five right-hand switches, A5 through A1, set the talk and listen addresses of the 5370B when it is used in the ADDRESSABLE mode. *Table 3-3* shows the possible address settings and the corresponding ASCII codes for talk and listen.

3-38. The examples listed in this section assume an address setting of 00011, which is a 5-bit binary code for the decimal number three. This number is important when using an HP 9825A calculator, since the calculator addresses the 5370B to talk and listen by using the code 703. (The "03" being the 5370B address.) The ASCII characters for this same switch setting are "C" for a talk address and "#" for a listen address. These characters are used when the computing controller is an HP 9830A calculator.

3-39. Program Codes

3-40. There are effectively three types of program codes that are used to remotely program the counter's functions. The first type uses two letters of the particular function, e.g., FN for FuNction, and a number associated with the specific function, see *Figure 3-9*. For example, selecting FN3 as the program code programs the frequency function. Notice that for commands such as FN, the front panel controls are numbered 1 through n, left to right and then top to bottom.

3-41. Other codes have only two functions, coded 0 and 1. The "0" indicates the selected function is off or disabled and the "1" indicates on or enabled. For example, EA0 is the code for EXT ARM disable.

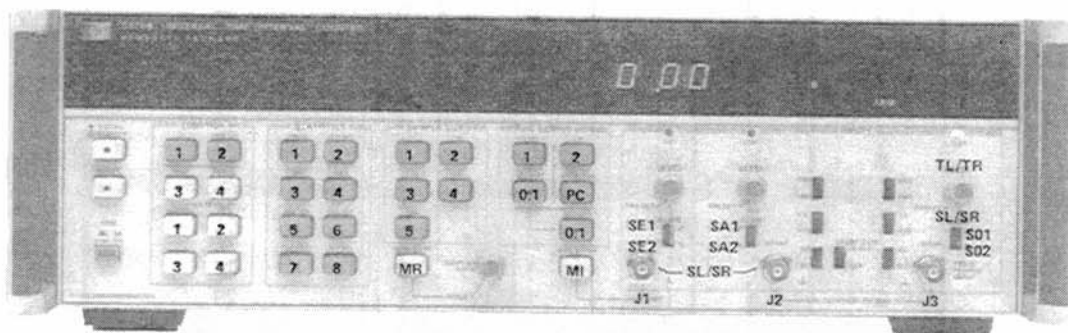
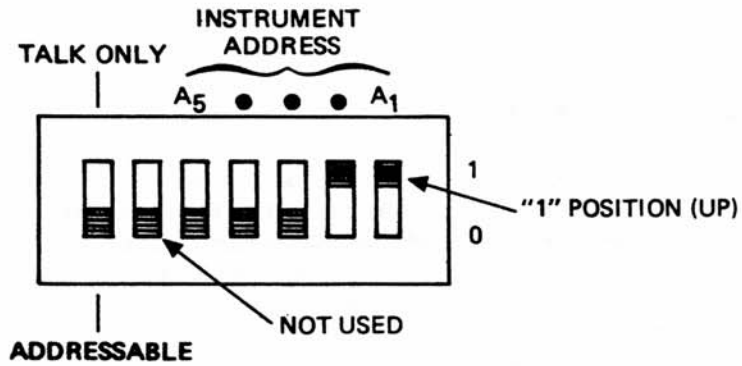

Figure 3-9. Program Codes Relating to Switch Functions



ASCII CODE CHARACTER		ADDRESS SWITCHES					DECIMAL EQUIVALENT OF BINARY SWITCH SETTING
LISTEN	TALK	A ₅	A ₄	A ₃	A ₂	A ₁	
SP	@	0	0	0	0	0	00
!	A	0	0	0	0	1	01
"	B	0	0	0	1	0	02
#	c	0	0	0	1	1	03
\$	D	0	0	1	0	0	04
%	E	0	0	1	0	1	05
&	F	0	0	1	1	0	06
'	G	0	0	1	1	1	07
(H	0	1	0	0	0	08
)	I	0	1	0	0	1	09
*	I	0	1	0	1	0	10
+	K	0	1	0	1	1	11
,	L	0	1	1	0	0	12
—	m	0	1	1	0	1	13
.	N	0	1	1	1	0	14
/	O	0	1	1	1	1	15
0	p	1	0	0	0	0	16
1	Q	1	0	0	0	1	17
2	R	1	0	0	1	0	18
3	s	1	0	0	1	1	19
4	T	1	0	1	0	0	20
5	u	1	0	1	0	1	21
6	v	1	0	1	1	0	22
7	w	1	0	1	1	1	23
8	x	1	1	0	0	0	24
9	y	1	1	0	0	1	25
:	z	1	1	0	1	0	26
;	[1	1	0	1	1	27
<	\	1	1	1	0	0	28
=]	1	1	1	0	1	29
>	~	1	1	1	1	0	30

3-42. The third type of function selection places portions of the front panel to either remote or local operation. For example, program code SR sets the slope switches to remote programming control. Program code SA1 or SA2 must now be programmed to choose the particular slope, positive or negative, for the START channel. These are the basic types of function codes for remote programming. Those that require special consideration are described in *Table 3-4, Program Code Set*.

3-43. Output Formats

3-44. The 5370B can output data in three different formats. Two of the formats are described in detail, in the back of this section, in Examples 2 and 5. Example 2 describes the Display All output format which outputs not only the resultant measurement but all related statistics. Example 5 describes in detail, the Binary Output or Computer Dump format. The third format is the Standard Output format and is described in the following paragraph.

3-45. The standard output byte contains 22 characters per measurement. The characters are arranged as follows:

AAAASD.DDDDDDDDDDDDESDD

where

A = TI = for Time Interval
FREQ = for Frequency
PER = for Period
S = Sign of measurement or exponent (space for positive and - for negative)
D = Digits
E = Exponent

The output byte is followed by a CR (carriage return) and LF (line feed).

Table 3-4. Program Code Set

Codes shown in **bold face** are start-up conditions. These conditions are set when the instrument powers up on turn-on. They cannot be selected by using the bus commands of Device Clear or Selected Device Clear.

1. **FUNCTION**
 FN1 **Time Interval**
 FN2 Trigger Levels
 FN3 Frequency
 FN4 Period
2. **GATE TIME** (for FREQUENCY or PERIOD mode)
 GT1 **Single Period**
 GT2 0.01 second
 GT3 0.1 second
 GT4 1 second
3. **STATISTICS**
 ST1 **Mean**
 ST2 Standard Deviation (requires >100 sample size)
 ST3 Minimum
 ST4 Maximum
 ST5 Display Reference
 ST6 Clear Reference (immediate execution)
 ST7 Display Events
 STB Set Reference (immediate execution)
 ST9 Display All. In the TIME INTERVAL mode, the counter displays and outputs the following: mean, standard deviation, minimum, maximum, reference, and events. In FREQUENCY or PERIOD mode with a gate time selected, the counter displays and outputs the following: mean and events. In FREQUENCY or PERIOD mode with a sample size selected, the counter displays and outputs the following: mean, standard deviation, minimum, maximum, and events (Use ST9 with a zero Reference value; see Example B.)
4. **SAMPLE SIZE**
 SS1 **Sample Size = 1**
 SS2 Sample Size = 100
 SS3 Sample Size = 1K
 SS4 Sample Size = 10K
 SS5 Sample Size = 100K
 } See also "SB", Sample Size Binary in this table.
5. **MODE**
 MD1 **Front Panel Display Rate Control is Functional.** Output only if addressed.
 MD2 Display Rate Hold Until "MR" command (or GET) (Display Rate control is locked out). Wait until addressed. Changing functions while in MD2 mode causes the first measurement output data to be invalid. With the new function programmed, the first data output will be the previous measurement data in terms of the new function. For example, with 5370B in frequency and a measurement of 1 MHz taken, if a new function was programmed, say Period, then the first output data will be 1 μ s (which is the previous Frequency measurement of 1 MHz converted to the new function of Period).
 MD3 Display Rate Fast (Display Rate control is locked out). Only if addressed.
 MD4 Display Rate Fast (Display Rate control is locked out). Wait until addressed. NOTE: Using MD4 causes the 5370B to assert SRQ (Service Request) after each measurement. This is useful when it is desirable to have the controller notified when a measurement ends.
6. **INPUT SELECTION** (see Example 3)
 IN1 **Input selection for normal time interval operation.** START event = START channel input, STOP event = STOP channel input.

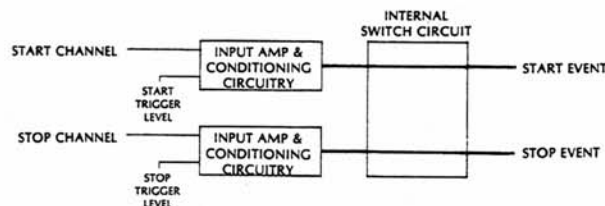

IN2 Normal input selection for frequency or period measurement. START event = STOP channel input, STOP event = STOP channel input.

NOTE

IN2 allows the following measurements to be made using the Time Interval Binary Output (TB1) mode:

1. Period measurements on the STOP channel using the T.I. function (FN1).
2. Period measurements preceded by cancellation of internal delay. With the T.I. function (FN1), first use \pm T.I. arming (AR2) and Set Reference (ST8) to compensate for the delay, then use +T.I. Only arming (AR1) to make the period measurements.

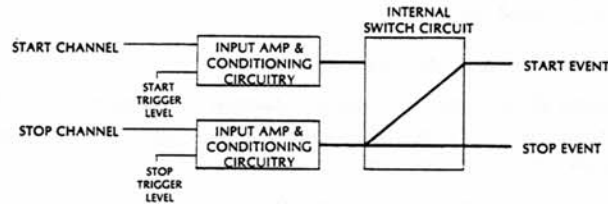

IN3 Input selection for operator convenience in switching input to a different channel. START event = START channel input, STOP event = START channel input. (Not equivalent to START COM mode.)

NOTE

IN3 allows the following measurements to be made using the Time Interval Binary Output (TB1) mode:

1. Period measurements on the START channel using the T.I. function (FN1).
2. Period measurements preceded by cancellation of internal delay. With the T.I. function (FN1), first use \pm T.I. arming (AR2) and Set Reference (ST8) to compensate for the delay, then use +T.I. Only arming (AR1) to make the period measurements.

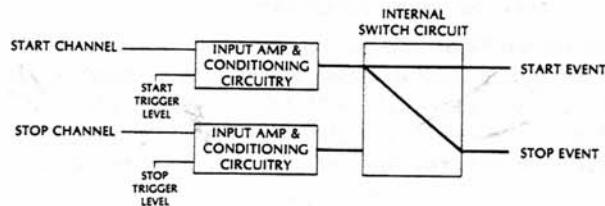

IN4 Input selection for operator convenience in switching inputs to different channels. START event = STOP channel input, STOP event = START channel input.

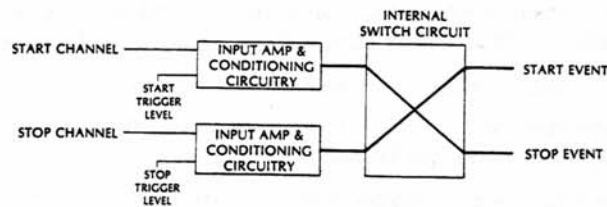

7. START CHANNEL SLOPE SELECT

- SA1 Start Channel Slope: Positive
- SA2 Start Channel Slope: Negative

8. STOP CHANNEL SLOPE SELECT

- SO1 Stop Channel Slope: Positive
- SO2 Stop Channel Slope: Negative

9. EXTERNAL ARM SLOPE SELECT

- SE1 External Arm Slope: Positive
- SE2 External Arm Slope: Negative

10. ARM SELECT

- AR1 +T.I. Arming Only
- AR2 +T.I. Arming

11. **EXTERNAL HOLDOFF**
EH0 External Holdoff Disable
EH1 External Holdoff Enable (must also use EA1 and AR1)
12. **EXTERNAL ARM**
EA0 External Arm Disable
EA1 External Arm Enable
13. **INTERNAL ARM**
Used with \pm T.I. Arm Mode only. Forces counter to arm on either START or STOP channel always, regardless of input phase relation. Disables internal phase detection circuit.
IA1 Internal Arm Auto
IA2 Start Channel Arm
IA3 Stop Channel Arm

The following terse commands have also been defined.

1. **MRM** Manual Rate. Used to initiate a sample of measurements. Typically used with MD2. MR must be sent at least 10 ms after the previous program command. For example, a typical 9825A program should be:
 - a. wrt 703, "FN1ST1SS1MD2IN1SA1SO2TRSR"
 - b. wait 10; wrt 703 "MR"
2. **MI** Manual Input. Same operation as front panel MANUAL INPUT. Used to manually arm the counter. Use wtb calculator command.
3. **SL** **Slope Local.** Set slope switches to local (front panel) operation.
4. **SR** Slope Remote. Sets slope switches to remote operation.
5. **TL** **Trigger Local.** Sets trigger level controls to front panel operation.
6. **TR** Trigger Remote. Set trigger level controls to remote operation.
7. **TE** Teach. When addressed to talk, the 5370B transfers all front panel information (or remotely programmed information) from its memory into the controller's memory. See Example 4.
8. **PC** Period Complement. Performs the same operation as the front panel switch.
9. **TB0** Disable Time Interval Binary Output.
10. **TB1** Time Interval Binary Output. For short time intervals OF <320 ps. Counter does not perform any type of statistical measurement (mean, standard deviation, etc.). Instead, counter outputs raw data: N0(ST), N1N2(CT1), N1N2(CT2), N0(CT1), and N0(CT2) in that order, and places "-----" in display. Measurements occur at up to a 6 kHz rate. See Example 5.
NOTE — Intended for use with plus or minus time interval arming mode only.

The following binary commands have also been defined.

1. **SB** Sample Size Binary. Allows a theoretical setting of sample sizes from 1 to 16,777,215. Must be entered in binary form. See Example 6. Use wtb calculator command.
2. **LN** Learn. Enters program information into 5370B (RAM memory) that was stored into the calculator with an earlier TEACH (TE) command. See Example 4.

The following decimal commands have also been defined.

1. **TA** Trigger Start. Sets the trigger level of the START channel from -2V to +2V (-0.00 is an illegal trigger level input). See Example 7.
2. **TO** Trigger Stop. Sets the trigger level of the STOP channel from -2V to +2V- See Example 7.

NOTE

To output the trigger level setup data from the 5370B to the controller, program the 5370B to Trigger Level function (FN2) and "red (counter talk address)". The output format is as follows:

```
STA = SD.DD,          STO = SD.DD  <CR LF>
where STA = START channel Trigger level
      S = Polarity of Trigger voltage
      D = Digit value
      STO = STOP Channel Trigger level
```

3-46. EXAMPLE PROGRAMS

3-47. Eight example programs are given as follows:

```
0: wrt 703,"FN3
  GT3MD2"
1: wrt 703,"MR";
  red 703,A;dsp
  A!wait 500
2: goto 1
*1132
```

EXAMPLE 1. TYPICAL MEASUREMENT FORMAT

This program forces the counter to perform a simple frequency measurement (FN3) with a 0.1 s gate time (GT3). The MD2 code prevents the counter from taking a measurement until the MR command is reached. The counter takes a measurement and reads it into the A register. The result is displayed by the calculator. After waiting 500 ms, the program loops back to the next "take a measurement" command (MR) and the process is repeated.

EXAMPLE 2. DISPLAY ALL STATISTICS

```
10 DIM C#E300
20 OUTPUT 703 : "MD2"
30 OUTPUT 703 : "ST1"
40 ENTER 703 : C#0 PRINT C#
50 OUTPUT 703 : "ST2"
60 ENTER 703 : C#0 PRINT C#
70 OUTPUT 703 : "ST3"
80 ENTER 703 : C#0 PRINT C#
90 OUTPUT 703 : "ST4"
100 ENTER 703 : C#0 PRINT C#
110 OUTPUT 703 : "ST5"
120 ENTER 703 : C#0 PRINT C#
130 OUTPUT 703 : "ST7"
140 ENTER 703 : C#0 PRINT C#
150 OUTPUT 703 : "MD1"
160 END
TI = 9.997500000000E-03
STD = 1.600000000000E-11
MIN = 9.994000000000E-03
MAX = 1.000400000000E-07
REF = 0.000000000000E-10
EVT = 1.000000000000E+02
```

This is an example program written in basic that allows the counter to display all statistical data available for a Time Interval measurement per sample size. Step 10 dimensions a string variable in the calculator to accept the forthcoming data. Step 20 programs the counter to hold data and prevents the counter from being updated by the next set of data (in other words, the front panel DISPLAY RATE CONTROL is disabled). Step 30 puts the counter in the Mean mode; while, Step 40 causes the counter to read into the string and print the contents of the string. Step 50 programs the counter into the Standard Deviation mode. Step 60 causes it to read into the string and print the contents of the string. Programming statements in Step 70 through 140 causes the counter to execute in the same manner described in Steps 30 through 60 (for program codes ST3, ST4, ST5, and ST7). Step 150 causes the front panel DISPLAY RATE CONTROL to be functional. The counter automatically selected 100 samples because a standard deviation was programmed. The output format for a Time Interval measurement is as follows:

```
T.I. = <CR LF>
STD = <CR LF>
MIN = <CR LF>
MAX = <CR LF>
REF = <CR LF>
EVT = <CR LF>
```

where

```
T.I. = Time Interval
STD = Standard Deviation
MIN = Minimum
MAX = Maximum
REF = Reference
EVT = Events
<CR LF> = Carriage Return, Line Feed
```

**This is from an old version of the manual.
For which I only have a poor electronic copy.**

```
0: flt 6
1: wrt 703,"FN1
  IN3"
2: red 703,A;
  dsp A;wait 2000
3: wrt 703,"FN3"
4: red 703,A;
  dsp A;wait 2000
5: eto 1
*31746
```

EXAMPLE 3. INPUT SELECTION

To demonstrate the input selection feature, connect signals of different frequencies to the input channels and set the START COM/SEP switch to SEP. Program Step 1 causes the counter to make a period measurement on the START channel signal. This is read and displayed in Step 2, along with a 2-second wait. Program Step 3 causes the counter to make a frequency measurement on the STOP channel signal. Step 4 duplicates Step 2, and Step 5 repeats the two measurements.

EXAMPLE 4. TEACH/LEARN

The following program serves as an example of the TEACH/LEARN mode. For demonstration purposes, perform the following steps:

1. Load the program into the 9825A Desk Top Computer.
2. Power up the 5370B.
3. On 5370B, push **FREQ**, **MIN**, and **SAMPLE SIZE** of 1K.
4. On 9825A, push **RUN**. The 5370B will teach the 9825A.
5. Turn 5370B power off, then on again. The counter will power up in **T.I.**, **MEAN**, **SAMPLE SIZE** of 1, and **+T.I.**
6. On 9825A, push **CONTINUE**.
7. 5370B will learn from the 9825A and the front panel will indicate **FREQ**, **MIN**, and **SAMPLE SIZE** of 1K.

```
0: dim A#[50]
1: buf "BIN",A#,
  3
2: wtb 703,"te"
3: tfr 703,"BIN"
  ,21
4: if rds("BIN")
  <0;eto +0
5: wrt 703,"nr"
6: dsp "5370B+98
  25A";beep;stp
7: wrt 703,"ln",
  A#[1,21]
8: dsp "9825A+53
  70B";beep;stp
*16965
```

The program sets the dimension of the A\$ string variable and names the buffer into which data will be read (BIN). It then specifies size of buffer (A\$) and selects the type of buffer: 3 equals fast read/write buffer. Step 2 programs 5370B to the TEACH mode. Step 3 transfers 21 bytes of information into buffer and step 4 ensures transfer is complete before continuing. Step 5 initiates a measurement. Step 6 displays message to indicate "TEACH" is complete. Step 7 generates the "LEARN" function, and step 8 gives a display to indicate the process is complete.

This is from an old version of the manual.

For which I only have a poor electronic copy.

EXAMPLE 5. TIME INTERVAL BINARY OUTPUT (Computer Dump)

NOTE — Intended for use with plus or minus time interval arming mode only.

The 5370B outputs raw measurement data in the following order: $N_0(ST)$, $N1N2(CT1)$, $N1N2(CT2)$, $N_0(CT1)$, and $N_0(CT2)$; where CT stands for count and ST stands for status. $N1N2$ is an 18-bit 2's complement quantity consisting of $N1N2(CT1)$, $N1N2(CT2)$, and the two least significant bits of $N_0(ST)$.

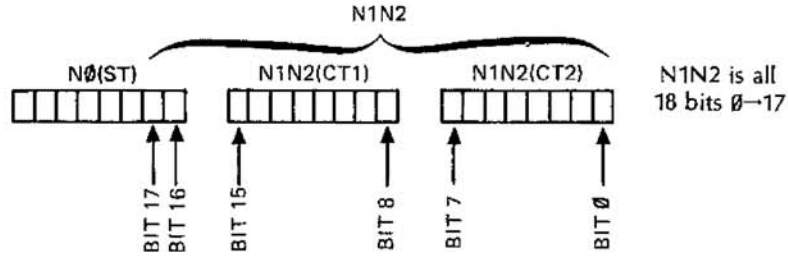

$N1N2$ actually represents the internal calculation of $257(N1-N2)$. This is done in preparation of solving the equation: T.I. $5 \left[\frac{257}{256} (N1-N2) + N_0 \right]$ ns. The number 257 in $257(N1-N2)$ is part of the ratio $257/256$.

$N_0(ST)$ contains the following status bits:

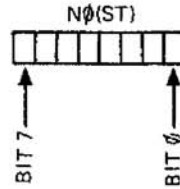

- Bit 7 = Event counter range flag
- Bit 6 = End of measurement
- Bit 5 = Sign of N_0 (High=+)
- Bit 4 = Armed flag
- Bit 3 = PLL out of lock flag
- Bit 2 = N_0 range flag
- Bit 1 = Bit 17 of $N1N2$
- Bit 0 = Bit 16 of $N1N2$

N_0 is a 16-bit quantity consisting of $N_0(CT1)$ and $N_0(CT2)$. It is expressed in sign-magnitude binary, **not** in 2's complement. To be complete, N_0 requires a sign, which is contained in bit 5 of $N_0(ST)$.

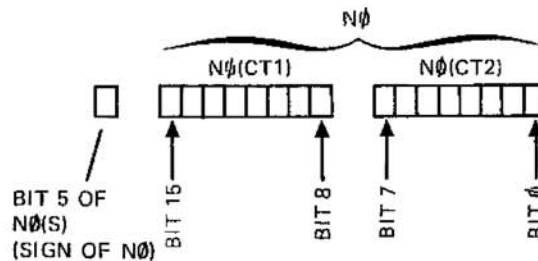

This is from an old version of the manual.

For which I only have a poor electronic copy.

These five bytes of data will give the measured time interval when combined in the following equation:

$$T.I. = [N1N2/256 + N0] 5 \text{ ns}$$

This can be rewritten for the 9825A example shown on the next page, by letting

$$N1N2 = B$$

$$N0 = N$$

$$\text{Sign of } N0 = Q$$

$$\therefore T.I. = (B/256 + N \cdot Q) 5e-9$$

9825A EXAMPLE PROGRAM. The following program causes the counter to output in the fast binary output mode, store the five bytes of data in a buffer, perform the calculation, and display the result. Data is entered into the following string variables.

```

A$(1) = N0(ST)
A$(2) = N1N2(CT1)
A$(3) = N1N2(CT2)
A$(4) = N0(CT1)
A$(5) = N0(CT2)
0: flt 6
1: dim A$(21);
  buf "ti",A$,3
2: wrt 703,"tb1"
3: buf "ti";tfr
  703,"ti",5
4: if rds("ti") <
  0;eto +0
5: num(A$(4))*
  256+num(A$(5))*
  N
6: 1→Q
7: if bit(5,num(
  A$(1)))=0;-1→Q
8: band(num(A$(1)
  ),3)*65536+
  num(A$(2))*256+
  num(A$(3))→B
9: if B>=131072;
  B-262144→B
10: (B/256+N*Q)*
  5e-9→T;dsp T
11: wait 500;
  eto 3
  *25017
  
```

PROGRAM STEP	PURPOSE
0:	Sets up floating point format for 6 digits.
1:	Sets up string variable (A\$) and specifies its size (21)*. Names buffer into which data will be read (ti) and specifies size of buffer (A\$). Selects type of buffer: 3 = fast read/write buffer.
2:	Programs 5370B to "fast binary output" mode (tb1).

*In 9825A, always allow for 16 bytes of "overhead"; then, allow for the number of bytes to be transferred. One sample = 16 + 5 = 21; one hundred sample = 16 + 5 (5 × 100) = 516.

**This is from an old version of the manual.
 For which I only have a poor electronic copy.**

- 3: Initializes buffer "ti" prior to inputting data. Transfer five bytes of data from 5370B into buffer "ti".
- 4: Reads status of transfer. Stays in transfer mode as long as status remains -1. When status goes to "5", program advances to next step.
- 5: Sets the two N0 bytes next to each other in their proper binary order and places that value in the variable N.
- 6: Assigns variable Q the value of 1.
- 7: Examines the sign of N0 bit (bit 5 of N0(ST)). If bit 5 is 0, the variable Q is given a negative number.
- 8: Removes bits 0 and 1 from N0(ST) and positions them and N1N2(CT1) and N1N2(CT2) in their proper binary order. Places that values in the variable B.
- 9: Tests the N1N2 number to determine if it is positive or negative. If number in B is less than $(2^{18})/2$, go to step 10. If number in B is equal to or greater than $(2^{18})/2$, subtract 2^{18} from B and place result in B. This converts B into a negative number.
- 10: Performs proper mathematical operation on data and displays result as time interval.
- 11: Wait half a second and repeat program.

HP-85 EXAMPLE PROGRAM. The following example program is in basic using a HP-85 controller. The program causes the counter to output in the fast binary output mode; store 500 bytes of data in a buffer; perform the calculation; and print the result.

```

10 C=0
20 M=0
30 DIM A$(500),Z$(500)
40 IOBUFFER Z$
50 OUTPUT 703 : "SS1TB1"
60 TRANSFER 703 TO Z$ FHS
70 ENTER Z$ USING "#, #K" ; A$
80 FOR I=1 TO 500 STEP 5
90 Q=1
100 N=NUM(A$(I+3))*256+NUM(A$(I+
4))
110 IF BIT(NUM(A$(I)),5)=0 THEN
Q=-1
120 B=BINAND(NUM(A$(I)),3)*65536
+NUM(A$(I+1))*256+NUM(A$(I+2
))
130 IF B>=131072 THEN B=B-262144
140 T=(B/256+N*Q)*.000000005
150 M=M+T
160 C=C+1
170 NEXT I
180 M=M/C
190 PRINT "MEAN OF SAMPLE SIZE":
C;"IS":M
200 END

```

**This is from an old version of the manual.
For which I only have a poor electronic copy.**

PROGRAM STEP	PURPOSE
10	Assigns variable C the value of 0. (C is the variable for SAMPLE SIZE).
20	Assigns variable M the value of 0. (M is the variable for storing sum of the TIME INTERVALS.
30	Sets up string variables A\$ and Z\$ and specifies there size*.
40	Sets up Z string as I/O buffer.
50	Programs 5370B to SAMPLE SIZE 1 (SS1) and to "fast binary output" mode (TB1).
60	Transfer 500 bytes of data from 5370B to the buffer Z string.
70	Enters data from buffer Z string to A string.
80	Sets up a loop (100 times).
90	Assigns variable Q the value 1.
100	Sets the two N0 bytes next to each other in their proper binary order and places the value in the variable N.
110	Examines the sign of N0 bit (bit 5 of N0(ST)). If bit 5 is 0, the variable Q is given a negative number.
120	Removes bits 0 and 1 from N0(ST) and positions them and N1N2(CT1) and N1N2(CT2) in their proper binary order. Places the value in the variable B.
130	Tests the N1N2 number to determine if it is positive or negative. If number in B is less than $(2^{18})/2$, go to step 140, if number in B is equal to or greater than $(2^{18})/2$, subtract 2^{18} from B and place result in B. This converts B into a negative number.
140	Equation for calculating Time Interval.
150	Accumulates total of 100 Time Intervals.
160	Counts number of Time Interval samples.
170	Increments loop.
180	Calculates the MEAN.
190	Prints the MEAN.

EXAMPLE 6. SAMPLE SIZE BINARY

```

0: wrt 703, "FN3
  ST7"
1: 568→S
2: wtb 703, "SB",
  int(S/65536),
  int((S-int(S/
  65536)*65536)/
  256), Smod256
3: stop
*4534

```

This program permits the selection of any sample size from 1 to a theoretical maximum of 16, 777, 215. "ST7" causes the counter to display the programmed sample size, assuming the counter is taking measurements. Step 1 indicates that, for this example, 568 samples are being requested. Change this number to change the sample size. Step 2 must always be programmed to allow proper data entry to the counter.

* In HP-85, always allow for 8 bytes of "overhead".

**This is from an old version of the manual.
For which I only have a poor electronic copy.**

EXAMPLE 7. REMOTE TRIGGER LEVELS

```

0: wrt 703, "FN2
  TR"
1: wrt 703, "TA
  -2"
2: wrt 703, "TO
  2"
3: end
*9047

```

This program causes the counter to display its trigger level (FN2) on the front panel and allows these levels to be set remotely (TR). "TA -2" sets the start channel trigger level (TA) to -2V; while "TO 2" sets the stop channel trigger level (TO) to 2V. Changing FN2 to FN1 will cause the counter to make a T.I. measurement at the programmed trigger levels.

This is an alternate program using a variable (T) for entering data.

```

0: wrt 703, "fn2t
  r"
1: -2+T
2: fmt f5.2
3: wrt 703, "to",
  T
4: 2+T;wrt 703,
  "to",T
5: end
*30013

```

EXAMPLE 8. DISPLAY ALL STATISTICS (Using ST9 with a Zero Reference)

```

0: dim C#[80],
  D#[80]
1: wrt 703, "ST6S
  T9"
2: red 703, C#, D#
3: prt C#, D#
4: wrt 703, "ST1"
5: stp
6: end
*11067

```

PROGRAM STEP**PURPOSE**

- | | |
|----|---|
| 0: | Sets up string variables and specifies their size for data input. |
| 1: | Clears the Reference and activates Display All Statistics mode. |
| 2: | Reads the data from the counter. |
| 3: | Displays the data on the calculator. |
| 4: | Exits from the ST9 mode. (This is necessary before changing any instrument settings.) |
| 5: | Stops program execution. |

**This is from an old version of the manual.
For which I only have a poor electronic copy.**

SECTION IV PERFORMANCE TESTS

4-1. INTRODUCTION

4-2. The three procedures in this section test the 5370B electrical performance using the specifications of *Table 1-1* as performance standards. The first test is an operation verification which checks all major functions of the 5370B via the front panel controls. The second test is an HP-IB operation verification which checks all major remote controllable functions of the 5370B. The third test is the full performance test which checks all specifications.

4-3. EQUIPMENT REQUIRED

4-4. Equipment required for the performance test is listed in *Table 1-2*, Recommended Test Equipment. Any equipment that satisfies the critical specifications given in the table may be substituted for the recommended models.

4-5. CALIBRATION CYCLE

4-8. The abbreviated checks given in *Table 4-1* can be performed to give a high degree of confidence the 5370B is operating properly without performing the complete performance test. The operation verification should be used for incoming QA, routine maintenance and after instrument repair.

4-9. HP-IB OPERATION VERIFICATION

4-10. The 9825A program listed in *Table 4-2* exercises the 5370B through the various operating modes via the HP-IB interface. If the 5370B successfully completes all phases of the verification program, there is a very high probability that the interface and counter are working properly. The HP-IB program is contained on a cassette, HP Part No. 59300-10001.

4-11. PERFORMANCE TEST

4-12. The performance test is given in *Table 4-3*. The performance test verifies all specifications listed in *Table 1-1*. All tests can be performed without access to the interior of the instrument.

4-13. TEST RECORD

4-14. Results of the performance tests may be tabulated on the Test Record at the end of *Table 4-3*. The test record lists all of the tested specifications and their acceptable limits. The results recorded at incoming inspection can be used for comparison in periodic maintenance and troubleshooting and after repairs or adjustments.

Table 4-1. Operation Verification

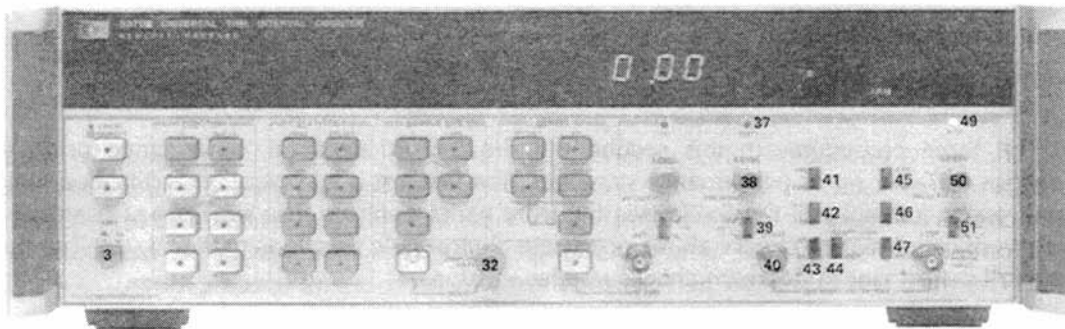

1. Before switching on the instrument, ensure that the power transformer primary is matched to the available line voltage, the correct fuse is installed, and the safety precautions are taken. See Power Requirements, Line Voltage Selection, Power Cables, and associated warnings and cautions in Section II of this manual. Description numbers match the numbers in *Figure 3-1* and *Figure 3-2*.
2. Connect a 4-foot BNC cable, such as HP 10503A, from the rear panel FREQ STD OUTPUT jack to the front panel START input jack [40].
3. Set the rear panel Frequency Select switch to INT.
4. Set the input impedance switches [41] [45] to the 50Ω position.
5. Set the attenuator switches [42] [46] to the +1 position.
6. Set the AC, DC switches [43] [47] to the DC position.
7. Set the input slope switches [39] [51] to the 1 (positive going slope) position.
8. Set the LEVEL controls [38] [50] to the preset position.
9. Set the COM, SEP switch [44] to the START COM position.
10. Adjust the DISPLAY RATE [32] to maximum (full cw).
11. Press the LINE switch [3] to turn the 5370B on.

NOTE

When the instrument is first turned on, the processor performs a selfcheck routine on the ROMs and RAMs. If, when power is first applied, or during operation, an error message is displayed, refer to paragraph 3-14 ERROR MESSAGES in Section III for error explanation.

12. For the first second after the instrument is turned on, the display will remain blank. For the next second, all segments and decimal points and all annunciator lights (except START, STOP, and ARM) in the display will be lit as well as LEDs in all the front panel switches.
13. After this initial power-up reset, the 5370B will be in T.I. FUNCTION, MEAN STATISTICS, SAMPLE SIZE 1, and +T.I. ONLY. The display should indicate 100.00 nanoseconds ±1.0 nanosecond with both the START and STOP channel trigger LEDs [37] [49] flashing. Also, because of the sample size of one, the ARM light will not be visible in the display.

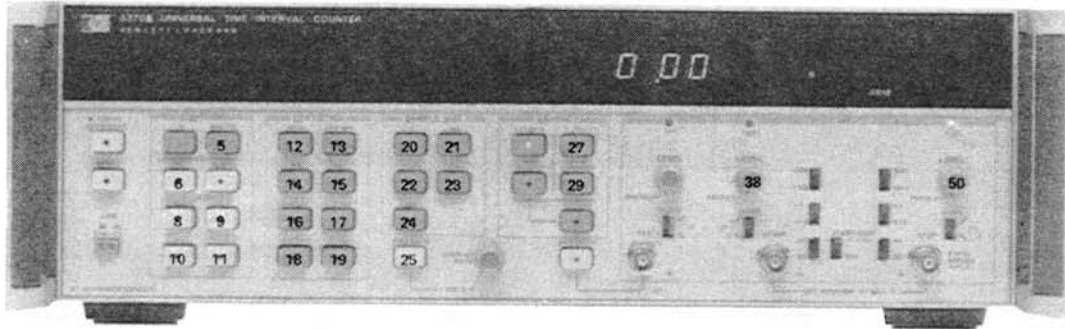

14. Press SAMPLE SIZE switch [21]. The least significant digit (LSD) will be one digit greater (1 picosecond), the ARM light will be visible and flashing and the LED in the MAN RATE switch [25] will be flashing at approximately the same rate as the ARM light. Press SAMPLE SIZE 1K switch [22] and display will have the same LSD (1 picosecond) with ARM light and MAN RATE switch flashing about twice per second. Press SAMPLE SIZE 10K [23] and display LSD will be 100 femtoseconds with ARM light flashing about once every four seconds. Press SAMPLE SIZE 100K switch [24] and the ARM light will flash about once every 40 seconds. Press SAMPLE SIZE 1 [20].
15. Press STD DEV [13] and \pm T.I. [27]. Display should read less than 100 ps (this reading is the instrument's jitter). Notice that SAMPLE SIZE automatically goes to 100. For STD DEV measurements, SAMPLE SIZE must be ≥ 100 . Press MIN switch [14] and minimum T.I. should be displayed. Press +T.I. only.
16. Press DSP REF switch [16] and three zeros should be displayed. Press SET REF switch [19] and approximately 100 nanoseconds should be displayed. This reference is the MEAN T.I. Press CLR REF switch [17] and six zeros should be displayed (if 99.99x ns was previously displayed, CLR REF will give five zeros), three zeros on either side of the decimal point. Press DSP EVTS switch [18] and 100 should be in the display. This number corresponds to the SAMPLE SIZE. Notice also EVT is displayed in the right-hand side of the window.
17. Press MEAN switch [12] and SAMPLE SIZE 1 switch [20]. Press \pm T.I. switch [27] and the display should show less than 1 nanosecond. The STOP or START light in the display will also be on. Press PERIOD COMPLMNT switch [29] and the display should be the same except the opposite (STOP or START) light will be on in the display. Press the PERIOD COMPLMNT switch again and the first light in the display should be on. This switch operation is identical to a toggle switch.
18. Press TRG LVL [5]. There will be two groups displayed, three digits each, on the left and the right of the display. They indicate the dc trigger level voltage on the START and STOP channel inputs, respectively. Rotate the LEVEL controls [38] [50] and note the voltage should change from approximately -2 to +2 volts. Turn both LEVEL controls fully counterclockwise until they click in the preset position. The display should show zero volts for both inputs.
19. Press FREQ switch [6]. Press 0.01s switch [9] and display should read approximately 10.000 000X MHz. Press 0.1s switch [10] and display should read approximately 10.000 000 0X MHz. Press 1s switch [11] and display should read approximately 10,000 000 0XX MHz. Press 1 PERIOD switch [8].

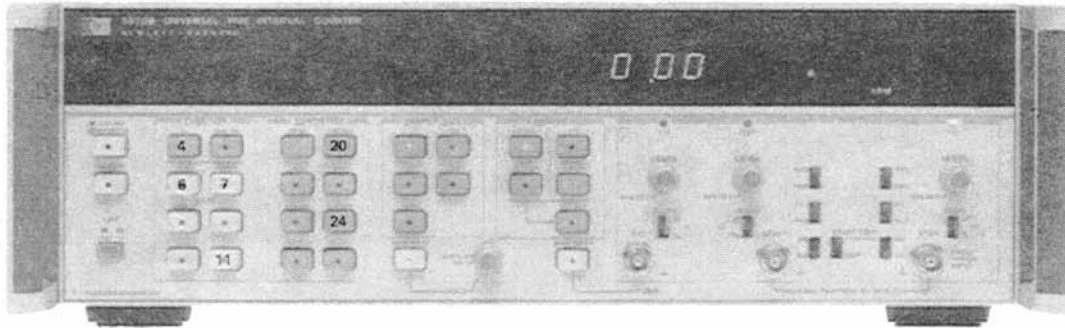

20. Press PERIOD switch [7]. Display should indicate approximately 100 nanoseconds.
21. Press T.I. switch [4], 100 K SAMPLE SIZE [24], rotate DISPLAY RATE control maximum cw and check the rear panel START and STOP outputs [1] and [2] using an oscilloscope. Both signals should be nominal -0.7V (into 50Ω) and approximately 360 μs wide as shown below.

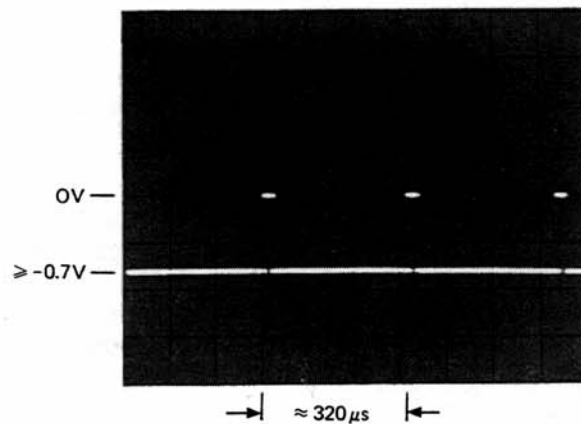

22. To check frequency input sensitivity, press FREQ [6], 1 second gate [11], SAMPLE SIZE 1 [20], both input amplifiers to 1 Meg, +1, DC, START COM, positive slope, and LEVELS to PRESET. Apply a 0.1 Hz signal at 100 mV amplitude to the START input. The reading should be 0.1 Hz. Apply a 100 MHz signal at 100 mV amplitude and reading should be 100 MHz.
23. If the 5370B is used in a system or via the HP-IB, perform EXAMPLE 1 (TYPICAL MEASUREMENT FORMAT) and EXAMPLE 4 (TEACH/LEARN) in Section III, and Table 4-2, which starts on the next page.

To perform the verification, setup the 5370B as shown below:

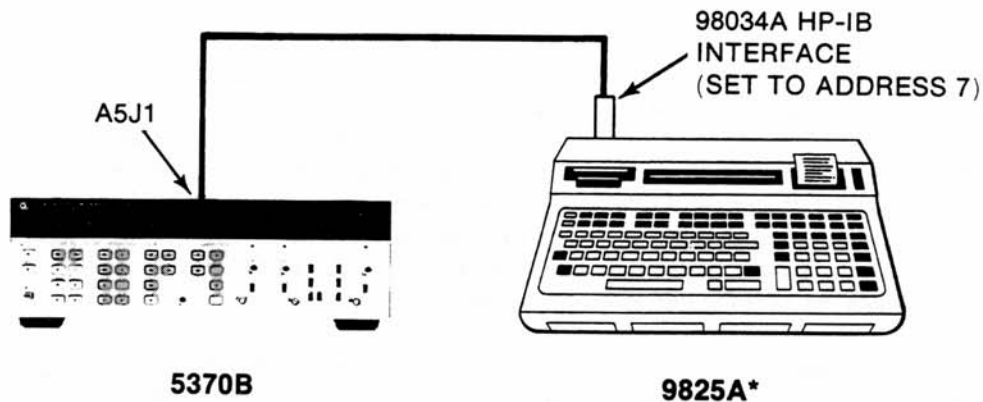

Perform the following steps:

1. Insert the cassette (HP P/N 59300-10001) into the 9825A.
2. Load and run file 0 (type: ldp0) press EXECUTE.
3. Type in model number of the instrument to be tested (example: 5370); push CONTINUE.
4. Set up counter as described in printout. Push CONTINUE.
5. Set up the 5370B rear panel ADDRESS switch (A5SW1) as follows:

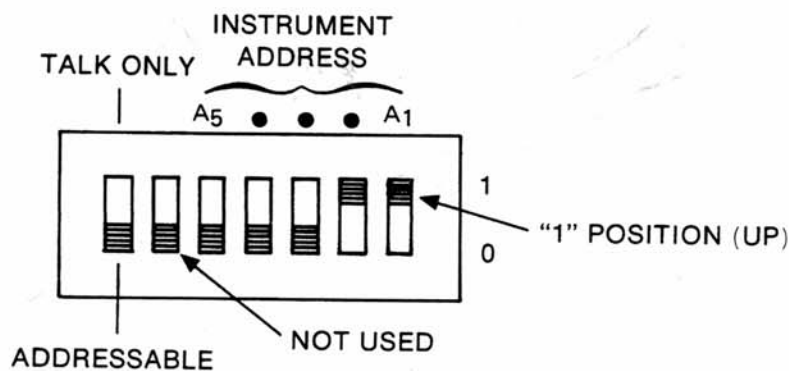

Type in select code 703; push CONTINUE.

NOTE

A select code other than 703 may be used. Remember to set the 5370B rear panel ADDRESS switch to correspond to the chosen select code. Do not use select code 721 (calculators address).

6. Always push CONTINUE to advance program.

NOTE

Leave the cassette tape in the calculator.

Because of the length of the test, the program is stored separately in files 14, 15, and 16. At the end of each file, the calculator will ask if you want to repeat one of the tests in that particular file. Answer 1 for yes and 0 for no, then push CONTINUE. If yes, the calculator then asks which test is to be repeated. Enter an appropriate number for tests contained in that particular file (as indicated on the calculator display), then push CONTINUE. The selected test is then repeated. At the end of that particular test, the question of whether or not to repeat a test is asked again. If you want to repeat the same test, simply push CONTINUE. If not, enter 0 and push CONTINUE. The program then automatically loads the next file into calculator memory.

Use the following procedure if it is desired to test a specific check point within a particular file. Load the tape in the normal manner and proceed until the calculator prints the check point 1 information. Type: cont "rpt". Then push

EXECUTE. The program will advance to the end of file 14 and ask if any of the tests need to be repeated. If so, use the method described above. If the desired program is on the next file, type 0 and push CONTINUE. The calculator will automatically load file 15 and print the first check point information. Push RECALL button on calculator to recall cont "rpt" statement. Then repeat the process described above.

File 14: Check Points 1 to 10
File 15: Check Points 11 to 16
File 16: Check Points 17 to 22

The HP-IB verification test contains 22 subtests. Each subtest is called a CHECK POINT. Each check point exercises a particular function or mode group as labeled on the 9825A printout.

Table 4-3. Performance Test

1. **SELF-TEST**

Perform steps 1 through 20 of the Operation Verification in Table 4-1. Mark the result on the test card. Perform the HP-IB Verification in Table 4-2. Mark the result on the test card.

2. **FREQUENCY/PERIOD RESPONSE**

Specification: 0.1 Hz to 100 MHz / 10 ns to 10 s

Equipment: HP 3325A HP 8656B

NOTE

Frequency and Period measurements are performed by the same circuitry. Frequency data is manipulated by the microprocessor to display period measurements. Period need only be spot checked assuming the 5370B passes Frequency Specifications.

2.1 Set the 5370B front panel controls as follows:

FUNCTION FREQ
 GATE 1s
 START COM/SEP SEP
 STOP CHANNEL
 LEVEL PRESET
 SLOPE f
 IMPEDANCE 50 Ω
 ATTENUATION + 1
 COUPLING DC

2.2. Connect the 3325A and 5370B as shown in the following diagram:

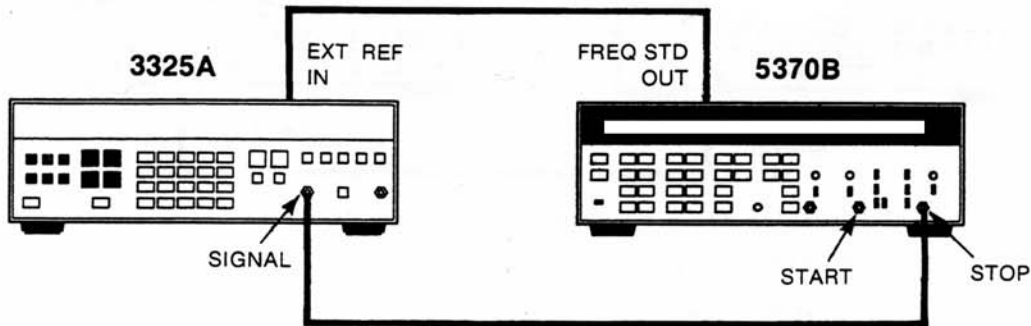

2.3 Set the 3325A for a 100 mV p-p square wave with no offset at the following frequencies. Switch the 5370B between FREQ and PERIOD functions:

3325A	HP 5370B DISPLAY	
	Frequency	Period
0.1 Hz*	0.1 Hz, ± 10 mHz	10 s, ± 1 ms
10 Hz	10 Hz, ± 1 mHz	0.1 s, ± 10 ms
1 kHz	1 kHz, ± 100 mHz	1 ms, ± 100 ns
100 kHz	100 kHz, ± 1 Hz	10 ms ± 1 ms
1 MHz	1 MHz, ± 10 Hz	1 ms ± 100 ps

2-4. Connect the 8656B and 5370B as shown in the following diagram:

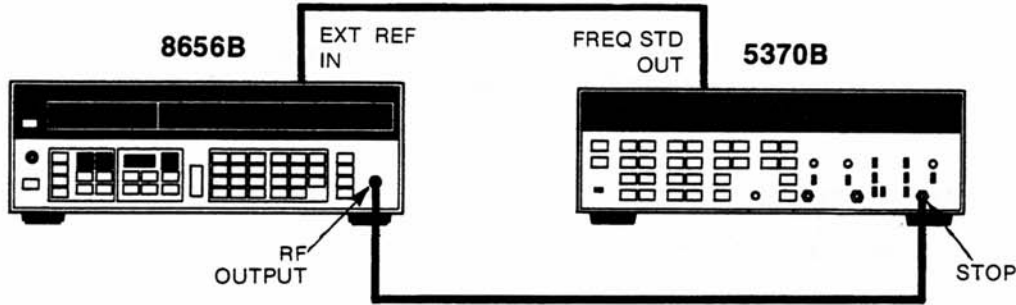

2-5. Set the 8656B for a 100 mV p-p signal at the following frequencies and switch the 5370B between FREQ and PERIOD functions:

8656B	HP 5370B DISPLAY	
	Frequency	Period
10 MHz	10 MHz, ± 100 Hz	100 ns ± 10 ps
100 MHz	100 MHz, ± 1 kHz	10 ns, ± 1 ps

Verify that the 5370B displays the correct frequency and period as indicated above. Mark the results on the test card.

3. TIME INTERVAL

Specification: -10 seconds to +10 seconds.

Equipment: HP 3325A

3.1. Connect the 3325A and 5370B as shown in the following diagram:

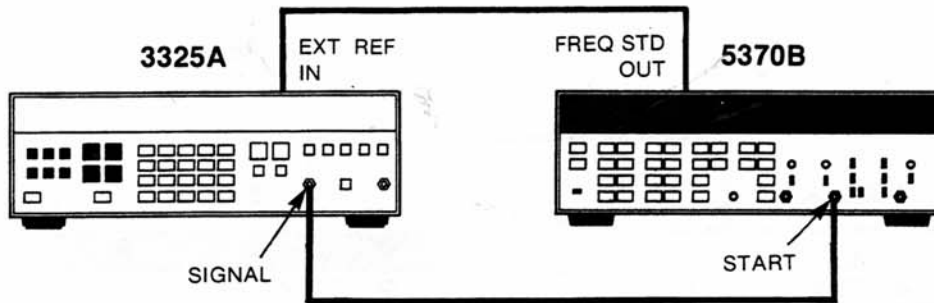

3.2. Set the 3325A for a .1 Hz square wave output. Set the output amplitude to 1 V p-p.

3.3. Set the 5370B front panel controls as follows:

- FUNCTION TI
- STATISTICS MEAN
- SAMPLE SIZE 1
- ARMING $\pm T.I.$
- START CHANNEL
- LEVEL PRESET
- SLOPE
- IMPEDANCE 50Ω
- ATTENUATION +1
- COUPLING DC
- START COM/SEP START COM

STOP CHANNEL
 LEVEL PRESET
 SLOPE
 IMPEDANCE 50Ω
 ATTENUATION +1
 COUPLING DC
 PERIOD COMPLMNT STOP (see display)

- 3.4 Verify that the 5370B displays a reading of +5s, ± 1 ms. Mark the result on the test card. (This measurement will take at least 10 second.)
- 3.5 Use PERIOD COMPLMNT to select START (see display)
- 3.6 Verify that the 5370B displays a reading of -10s, ±10ms. Mark the result on the test card.

4. SENSITIVITY

Specifications:

SEPARATE INPUTS — 100 mV p-p times attenuator setting

COMMON INPUT — 200 mV p-p times attenuator setting for 50Ω input impedance,
 1 MΩ same as Separate Inputs.

Equipment: HP 3325A

A. SEPARATE INPUTS

- 4.1 Connect the 3325A and 5370B as shown in the following diagram:

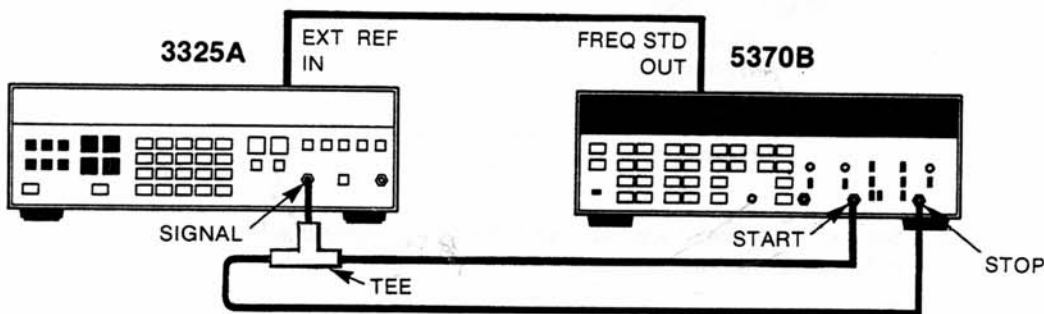

NOTE: Use BNC cables of equal length from 3325A output to 5370B inputs.

- 4.2. Set the 3325A for a 10 kHz square wave output. Set the output amplitude to 200 mV p-p.
- 4.3 Set the 5370B front panel controls as follows:

FUNCTION TI
 STATISTICS MEAN
 SAMPLE SIZE 1k
 ARMING +T.I.
 START CHANNEL
 LEVEL PRESET
 SLOPE
 IMPEDANCE 50Ω
 ATTENUATION +1
 COUPLING DC
 START COM/SEP SEP
 STOP CHANNEL
 LEVEL PRESET
 SLOPE
 IMPEDANCE 50Ω
 ATTENUATION +1
 COUPLING DC

4.4 Verify that the 5370B displays a reading of 100 μs , ± 1 ns. Mark the result on the test card.

4.5 Change the 5370B front panel controls as follows:

START CHANNEL
ATTENUATION.....+10
STOP CHANNEL
ATTENUATION.....+10

4.6 Set the 3325A output amplitude to 1V p-p. Verify that the 5370B displays a reading of 100 μs , ± 3 ns. Mark the result on the test card.

4.7 Connect the 3325A and 5370B as shown in the following diagram:

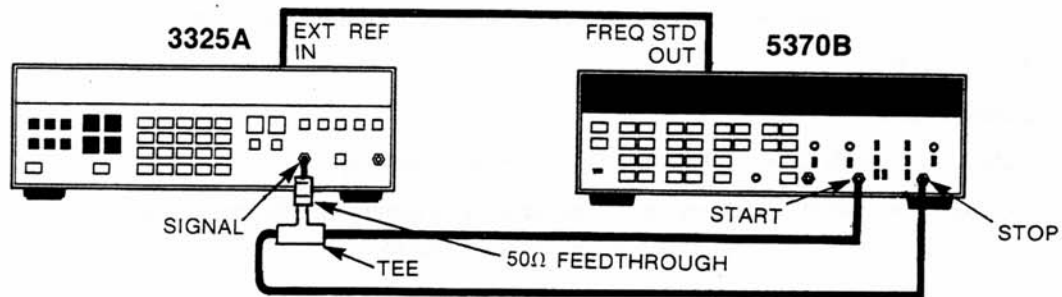

NOTE: Use BNC cables of equal length from 3325A output to 5370B inputs.

4.8 Change the 5370B front panel controls as follows:

START CHANNEL
IMPEDANCE 1M Ω
ATTENUATION.....+1
STOP CHANNEL
IMPEDANCE 1M Ω
ATTENUATION.....+1

4.9 Set the 3325A output amplitude to 100 mV p-p. Verify that the 5370B displays a reading of 100 μs , ± 3 ns. Mark the result on the test card.

4.10 Change the 5370B front panel as controls as follows:

START CHANNEL
ATTENUATION.....+10
STOP CHANNEL
ATTENUATION.....+10

4.11 Set the 3325A output amplitude to 1V p-p. Verify that the 5370B displays a reading of 100 μs , ± 3 ns. Mark the result on the test card.

B. COMMON INPUT

4-12. Connect the 3325A and 5370b as shown in the following diagram:

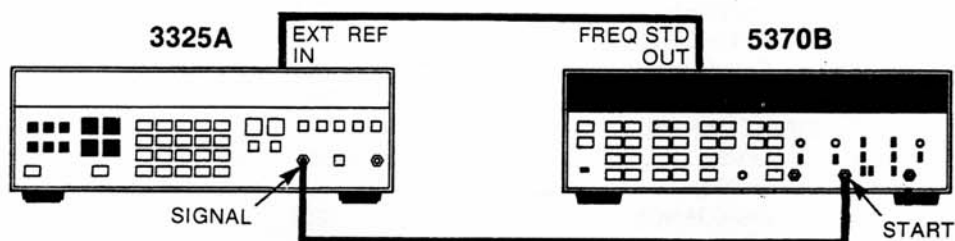

4-13. Change the 5370B front panel controls as follows:

```

START CHANNEL
  IMPEDANCE ..... 50Ω
  ATTENUATION ..... +1
START COM/SEP ..... START COM
STOP CHANNEL
  IMPEDANCE ..... 50Ω
  ATTENUATION ..... +1
  
```

4-14. Set the 3325A output amplitude to 200 mV p-p. Verify that the 5370B displays a reading of 100 μs, ±3 ns. Mark the result on the test card.

4-15. Change the 5370B front panel controls as follows:

```

START CHANNEL
  ATTENUATION ..... +10
STOP CHANNEL
  ATTENUATION ..... +10
  
```

4-16. Set the 3325A output amplitude to 2V p-p. Verify that the 5370B displays a reading of 100 μs, ±1 ns. Mark the result on the test card.

4-17. Connect the 3325A and 5370B as shown in the following diagram:

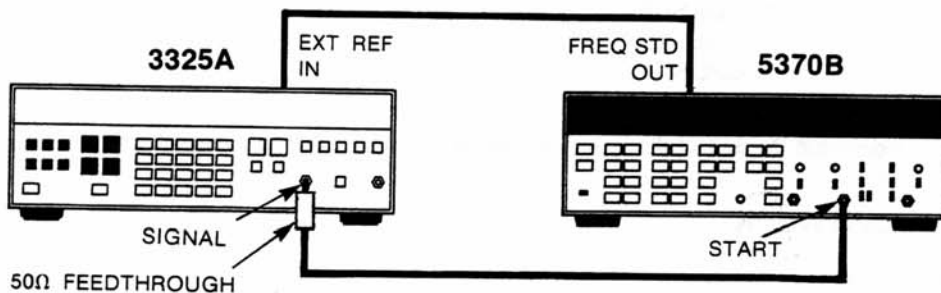

4-18. Change the 5370B front panel controls as follows:

```

START CHANNEL
  IMPEDANCE ..... 1 MΩ
  ATTENUATION ..... +1
STOP CHANNEL
  IMPEDANCE ..... 1MΩ
  ATTENUATION ..... +1
  
```

4-19. Set the 3325A output amplitude to 100 mV p-p. Verify that the 5370B displays a reading of 100 μs, ±3 ns. Mark the result on the test card.

4-20. Change the 5370B front panel controls as follows:

```

START CHANNEL
  ATTENUATION ..... +10
STOP CHANNEL
  ATTENUATION ..... +10
  
```

4-21. Set the 3325A output amplitude to 1V p-p. Verify that the 5370B displays a reading of 100 μs, ±3 ns. Mark the result on the test card.

5. ACCURACY

Specification: 10 MHz, ± 0.005 Hz.

5.1 Connect the 5370B as shown in the following diagram:

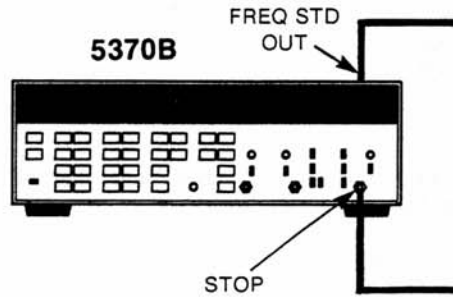

5.2 Set the 5370B front panel controls as follows:

FUNCTION FREQ
 GATE.....1 s
 STATISTICSMEAN
 STOP CHANNEL
 LEVEL..... PRESET
 SLOPE
 IMPEDANCE 50 Ω
 ATTENUATION..... +1
 COUPLING DC
 START COM/SEP SEP

5.3 Verify that the 5370B displays a reading of 10 MHz, ± 0.005 Hz. mark the result on the test card.

6. MINIMUM PULSE WIDTH

Specification: 5 ns

Equipment: HP 5359A

6.1 Connect the 5359A and 5370B as shown in the following diagram:

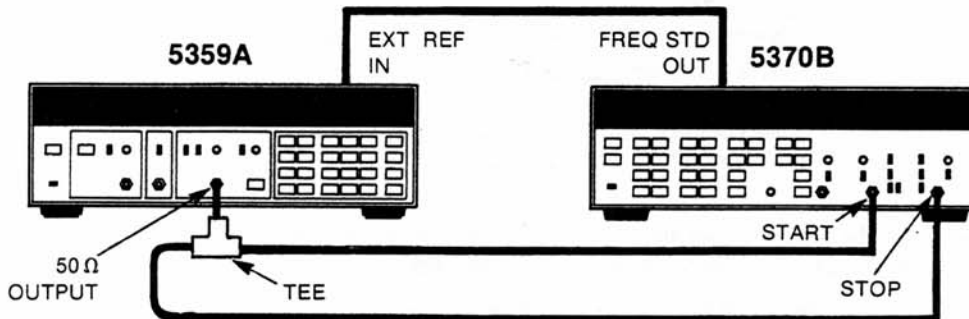

NOTE: Use BNC cables of equal length from 5359A output to 5370B inputs.

6.2 Set the 5359A front panel controls as follows:

OUTPUT
 POLARITY NORM/POS
 AMPLITUDE.....2 V
 OFFSET -1 V
 PERIOD100 μ s
 WIDTH5 ns

- 6.3 Press the CAL button on the 5359A front panel.
- 6.4 Set the 5370B front panel controls as follows:

```

FUNCTION ..... TI
STATISTICS ..... MEAN
SAMPLE SIZE ..... 1k
ARMING ..... ±T.I.
START CHANNEL
  LEVEL ..... PRESET
  SLOPE .....
  IMPEDANCE ..... 50Ω
  ATTENUATION ..... ÷1
  COUPLING ..... DC
START COM/SEP ..... SEP
STOP CHANNEL
  LEVEL ..... PRESET
  SLOPE .....
  IMPEDANCE ..... 50Ω
  ATTENUATION ..... ÷1
  COUPLING ..... DC
PERIOD COMPLMNT ..... STOP (see display)
  
```

- 6.5 Verify that the trigger lights are flashing and the 5370B displays a reading of 5 ns, ±1 ns. Mark the result on the test card.
- 6.6 Change the 5370B front panel controls as follows:

```

ARMING ..... +T.I. ONLY
STOP CHANNEL
  SLOPE .....
  
```

- 6.7 Verify that the trigger lights are flashing and the 5370B displays a reading of 100 μs, ±1 ns. Mark the result on the test card.

7. JITTER

Specification: 35 ps TYPICAL, 100 ps MAXIMUM

Equipment: HP 5359A

- 7.1 Connect the 5359A and 5370B as shown in the following diagram:

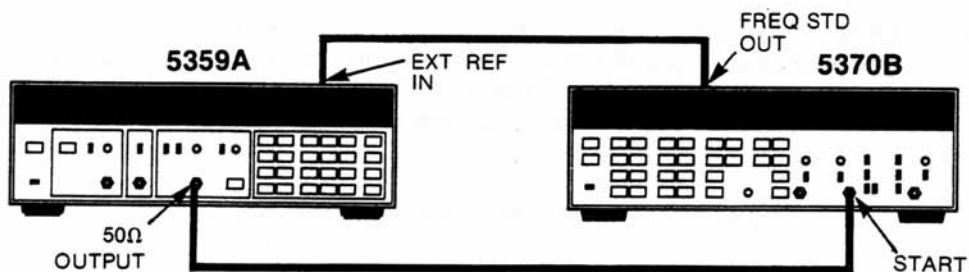

- 7.2 Set the 5359A front panel controls as follows:

```

OUTPUT ..... NORM/POS
POLARITY ..... 2 V
AMPLITUDE ..... -1 V
OFFSET ..... 10 kHz
FREQ ..... 10 kHz
WIDTH ..... 10 ns
  
```

- 7.3 Press the CAL button on the 5359A front panel.
- 7.4 Set the 5370B front panel controls as follows:

FUNCTION TI
 STATISTICS STD DEV
 SAMPLE SIZE 1k
 ARMING \pm T.I.
 BOTH CHANNELS
 LEVEL PRESET
 SLOPE
 IMPEDANCE 50 Ω
 ATTENUATION \div 1
 COUPLING DC
 START COM/SEP START COM

- 7.5 Verify that the 5370B displays a reading of less than 100 ps (35 ms TYPICAL). Mark the result on the test card.

8. DYNAMIC RANGE

Specification: 100 mV p-p to 4 V p-p into 50 Ω \div 1

Equipment: HP 3325A

- 8.1 Connect the 3315A and 5370B as shown in the following diagram:

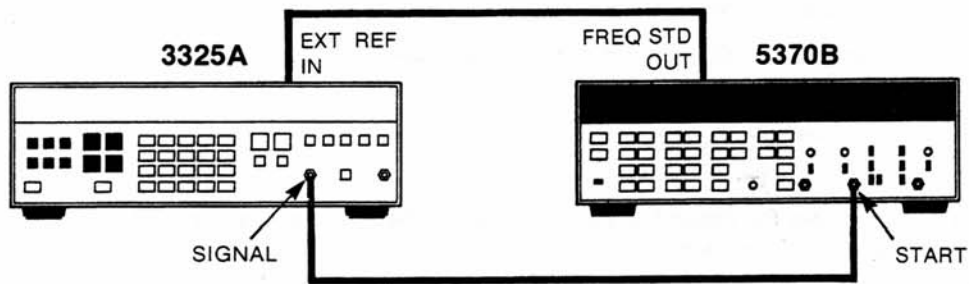

- 8.3 Set the 3325A for a 100 kHz square wave output. Set the output amplitude to 200 mV p-p. (The 5370B effectively “sees” 100 mV p-p at both input channels. This is because the input signal is divided by two when the 5370B is set to START COM and 50 Ω input impedance.) Verify that the 5370B displays a reading of 10 μ s, \pm 1 ns, Mark the result on the test card.
- 8.4 Set the 3325A output amplitude to 8 V p-p square wave at 100 kHz. (The 5370B effectively “sees” 4V p-p at both input channels. This is because the input signal is divided by two when the 5370B is set to START COM and 50 Ω input impedance.) Verify that the 5370B displays a reading of 10 μ s, \pm 1 ns. Mark the result on the test card.

THIS COMPLETES THE PERFORMANCE TESTS FOR THE 5370B.

HP 5370B PERFORMANCE TEST CARD

Hewlett-Packard Model 5370B
UNIVERSAL TIME INTERVAL COUNTER

Serial Number: _____ Repair/Work Order No. _____

Test Performed By: _____ Temperature: _____

Date: _____ Relative Humidity: _____

Notes: _____ Post Calibration Test:

Pre Calibration Test:

PARAGRAPH NUMBER	TEST	RESULTS		
		PASS	FAIL	
1.	SELF TEST Operation Verification HP-IB Verification	_____	_____	
		MINIMUM	ACTUAL	MAXIMUM
2.	FREQUENCY/PERIOD RESPONSE Amplitude = 100 mV p-p 100 mHz (0.1 Hz) 10 Hz 1 kHz 100 kHz 1 MHz 10 MHz 100 MHz	99.990 mHz 9.999 Hz 999.9 Hz 99.99 kHz 999.9 kHz 9.999 MHz 99.99 MHz	_____	100.010 mHz 10.001 Hz 1000.1 Hz 100.01 kHz 1.0001 MHz 10.001 MHz 100.01 MHz
3.	TIME INTERVAL + 10 s - 10 s	+9.99 s -10.01 s	_____	+10.01 s -9.99 s
4.	SENSITIVITY A. Separate Inputs 100 mV p-p, 50 Ω, ÷1 1 V p-p, 50Ω, ÷10 100 mV p-p, 1 MΩ, ÷1 1 V p-p, 1MΩ, ÷10 B. Common Input 200 mV p-p, 50 Ω, ÷1 2 V p-p, 50Ω, ÷10 100 mV p-p, 1 MΩ, ÷1 1 V p-p, 1MΩ, ÷10	99.999 μs 99.999 μs 99.999 μs 99.999 μs 99.999 μs 99.999 μs 99.999 μs 99.999 μs	_____	100.001 μs 100.001 μs 100.001 μs 100.001 μs 100.001 μs 100.001 μs 100.001 μs 100.001 μs
5.	ACCURACY 10 MHz	9.999 999 995 MHz	_____	10.000 000 005 MHz
6.	MINIMUM PULSE WIDTH 5 ns	4 ns 99.999 μs	_____	6 ns 100.001 μs
7.	JITTER 35 ps typical, 100 ps maximum	0	_____	100 ps
8.	DYNAMIC RANGE (PRESET) 200 mV p-p, 50Ω, START COM 8 V p-p, 50Ω, START COM	9.999 μs 9.999 μs	_____	10.001 μs 10.001 μs

SECTION V ADJUSTMENTS

5-1. INTRODUCTION

5-2. This section describes the adjustments which will return the 5370B to peak operating condition after repairs are completed or for periodic preventative maintenance. If the adjustments are to be considered valid, the 5370B must have a half-hour warm-up and the line voltage must be within +5% to -10% of nominal.

5-3. Generally, only the repaired assembly needs to be adjusted. The exception is the A3 and A4 assemblies (05345-60138 and 05345-60124, respectively), which should be adjusted together. The order or sequence in which the assemblies are adjusted is critical only when A3/A4 assemblies have been repaired or replaced. A3 and A4 input assemblies should be adjusted first and then the Interpolators (A19/A20) should be adjusted. Lastly, the phase adjustment on the A18 DAC/N0 assembly should be done.

5-4. The adjustment procedures are listed in numeric order according to the assembly number (A3, A4, A18, A19, etc.) for quick and easy reference.

5-5. SAFETY CONSIDERATIONS

5-6. Although the HP 5370B has been designed in accordance with international safety standards, this manual contains information, cautions, and warnings which **MUST** be followed to ensure safe operation and to retain the 5370B in safe condition (also see Sections II and III of this manual). Service and adjustments should be performed only by qualified personnel.

WARNING

ANY INTERRUPTION OF THE PROTECTIVE (GROUNDING) CONDUCTOR (INSIDE OR OUTSIDE THE 5370B OR DISCONNECTION OF THE PROTECTIVE EARTH TERMINAL IS LIKELY TO MAKE THE 5370B DANGEROUS.

5-7. Any adjustment, maintenance, or repair of the opened 5370B with voltage applied should be avoided as much as possible and, when inevitable, should be carried out by a skilled person who is aware of the hazard involved. Capacitors inside the 5370B may still be charged even if the 5370B has been disconnected from its source of supply.

5-8. Make sure that only fuses with the required rated current and of the specified type are used for replacement. The use of repaired fuses and the short circuiting of fuseholders must be avoided. Whenever it is likely that the protection offered by fuses has been impaired, the 5370B must be made inoperative and secured against any unintended operation.

WARNING

ADJUSTMENTS DESCRIBED HEREIN ARE PERFORMED WITH POWER SUPPLIED TO THE 5370B WHILE PROTECTIVE COVERS ARE REMOVED. ENERGY AVAILABLE AT MANY POINTS MAY, IF CONTACTED, RESULT IN PERSONAL INJURY.

5-9. EQUIPMENT REQUIRED

5-10. The test equipment required for all of the adjustment procedures is listed in *Table 1-2, Recommended Test Equipment*. The test equipment required for the adjustment of each particular assembly is listed at the beginning of the adjustment procedure for that assembly. This listing is a duplicate of the listing in *Table 1-2* and is supplied as a quick reference. The critical specifications of substitute test instruments must meet or exceed the standards listed in *Table 1-2* if the HP 5370B is to meet the specifications in *Table 1-1*.

5-11. ADJUSTMENT LOCATIONS

5-12. As an adjustment aid, locators are given for each assembly adjustment procedure and appear at the end of each adjustment procedure. These locators are photos and/or simplified illustrations of the assembly showing variable resistors, variable capacitors, test points, etc., needed for adjustment of the assembly.

5-13. Adjustment Procedure

5-14. The adjustment procedures for the assemblies in the HP 5370B are given in the following tables. *Table 5-1* is for the Input Assemblies (A3, A4); *Table 5-2* is for the DAC/NO Logic Assembly (A18); *Table 5-3* is for the Interpolator Assemblies (A19, A20); *Table 5-4* is for the 200 MHz Multiplier Assembly (A21); *Table 5-7* is for Arming Assembly (A22); and *Table 5-8* is for the Crystal Controlled Oscillator (A69).

5-15. ASSEMBLY REMOVAL AND REPLACEMENT

5-16. All of the assemblies, with the exception of the A3/A4 Input Assembly and A22 Arming Assembly can be easily removed from the HP 5370B by pulling the assembly straight up, out of the motherboard connector. The A22 assembly, in addition to plugging into the motherboard, has the A3/A4 Input Assembly connected to it at a right angle. For this reason, a removal and installation procedure is given in *Table 5-5* and *Table 5-6*, respectively.

Table 5-1. A3/A4 Input Assembly

NOTE

The A3 and A4 assemblies must be tested together as a unit.

Equipment:

- HP 1725 A Oscilloscope
- HP 8082A Pulse Generator
- * HP 182C Mainframe Oscilloscope
- * HP 1810A 1 GHz Sampling Plug-in
- HP 3435A DMM
- HP 8660C Synthesized Signal Generator
- HP 10503-6001 BNC Cables (2 matched length $\pm 1/2$ -in)
- HP 05062-60186 Female SMC to Female SMC Cable (2 matched length $\pm 1/2$ -in)
- HP 10503-6001 BNC Cables (5 each)

Accessories:

- (2) BNC to miniature male SMC RF connector (P/N 1250-0831)
- Ceramic Tuning Wand

Setup:

NOTE 1

Adjustment locators for A3 and A4 assemblies are located at the end of this table.

NOTE 2

Setup adjustment performed with no signal input.

1. Set START and STOP LEVEL controls to PRESET, and SLOPE switches to *F*.
2. Adjust all potentiometers (R3, R11, R12, and R8) on the A4 board to center position.

NOTE

Allow a half hour warm-up before performing the following adjustment procedure.

DUTY CYCLE ADJUSTMENT TO ATTAIN 20 mV SENSITIVITY

1. Set the 3435A DMM controls as follows:

FUNCTION..... Vdc
RANGE 200 mV

2. Connect 3435A DMM positive lead to Pin 8 of A3U2 (START Channel Hybrid) and connect negative lead to Pin 11 (∇) of A3U2. If the dc voltage reading is **less than** 100 mV continue to Step 3. If the dc voltage reading is **greater than** 100 mV **select** R44 until dc voltage at Pin 8 reads less than 100 mV.

NOTE 2

Increase R44 value causes offset voltage at Pin 8 of A3U2 to increase; whereas, decreasing R44 value causes the offset voltage to decrease.

3. Connect 3435A DMM positive lead to Pin 7 of A3U1 (STOP Channel Hybrid) and connect negative lead to Pin 11 (∇) of A3U1. If the dc voltage reading is **less than** 100 mV continue to START Channel Sensitivity Adjustment (next step). If the dc voltage reading is **greater than** 100 mV **select** R7 until dc voltage at Pin 8 reads less than 100 mV.

NOTE

Increasing R7 value causes offset voltage at Pin 7 of A3U1 to increase; whereas, decreasing R7 value causes the offset voltage to decrease.

*If you do not have an HP 182C/1810A scope, use another 1 GHz Oscilloscope of equivalent or better specifications.

START Channel Sensitivity Adjustment:

1. Connect a BNC cable from the 8660C RF OUTPUT to the 5370B START input.
2. Connect a BNC cable from 8660C EXT TIMEBASE (rear panel) to the 5370B 10 MHz FREQ STD OUTPUT (rear panel) to lock the 8660C with the 5370B timebase.
3. Set the 8660C frequency to 100 MHz and amplitude to 20 mV.
4. Set the 182C/1810A Oscilloscope controls as follows:
MODE..... A
..... A TRIG
POLARITY +UP (both channels)
GAIN 20 mV/cm (both channels)
TIME DIV EXPANDED
..... 2 ns/cm
TRIGGER..... NORM
..... +SLOPE
..... EXT
SCAN SWEEP
5. Set the 5370B input controls (both channels) as follows:
SEP/START COM..... SEP
IMPEDANCE 50
COUPLING DC
LEVEL..... PRESET
ATTENUATION..... $\div 1$
SLOPE..... f
6. Connect a SMC cable (05060-60186) from Channel A input of the 1810A plug-in to A22J7. (Connect a BNC to male SMC RF connector to one side of the SMC cable to enable connection to the oscilloscope.)
7. Observe that the 5370B Counter is triggering and waveform appears on 182C Oscilloscope screen.

NOTE

Triggering may not occur and the waveform may not be present. A3R41 may be too far out of adjustment; if this is the case do adjustment in Step 8. If waveform is present skip to Step 9.

8. Adjust A3R41 until waveform appears on 182C display.
9. Continue to adjust A3R41 until waveform is symmetrical.
10. Toggle SA SLOPE switch up and down; observe that waveform maintains its symmetrical form. If waveform doesn't maintain its symmetrical form, then replace the Hybrid (U2); and, repeat steps 6 through 10.
11. The 5370B START Channel is now calibrated for 20 mV sensitivity.

STOP Channel Sensitivity Adjustment:

1. Set 1810A plug-in to Channel B, TRIG B, INT TRIG.
2. Connect a SMC cable (05060-60186) from Channel B input of the 1810A plug-in to A22J8. (Connect a BNC to male SMC RF connector to one side of the SMC cable to enable connection to the oscilloscope.)
3. Observe that the 5370B Counter is triggering and waveform appears on 182C Oscilloscope screen.

NOTE

Triggering may not occur and the waveform may not be present. A3R3 may be too far out of adjustment; if this is the case, do adjustment in Step 4. If waveform is present skip to Step 5.

4. Adjust A3R3 until waveform appears on 182C screen.
 5. Continue to adjust A3R3 until waveform is symmetrical.
 6. Toggle SO SLOPE switch up and down; observe that waveform maintains its symmetrical form. If waveform doesn't maintain its symmetrical form, then replace the Hybrid (U1); and repeat steps 2 through 6.
 7. The 5370B START Channel is now calibrated for 20 mV sensitivity.
-

PULSE RESPONSE ADJUSTMENT

1. Connect a BNC cable from the 8082A OUTPUT/OUTPUT to the 1725A Channel A input.
2. Set the 8082A Pulse Generator controls as follows:
 - AMPLITUDE (50 LOAD)..... 1.0V TO 2.0V range
 - OFFSETON
 - OUTPUT POLARITYNEGATIVE COMPLEMENT
 - TRANSITION TIME..... 1 ns to 5 ns range
 - LEADING EDGE full ccw
 - TRAILING EDGE full ccw
 - PULSE PERIOD 0.1 μ s to 1 μ s range
 - VERNIER midrange
 - PULSE DELAY 2 ns to 5 ns range
 - VERNIER full cw
 - PULSE WIDTH 5 ns to 50 ns range
 - VERNIER midrange
 - PULSE normal
 - TRIGGER SWITCH NORM
 - EXT INPUT SLOPE/POLARITY NEG
3. Set the 1725A Oscilloscope controls as follows:
 - CHANNEL A GND
 - 0.5/div.
 - HORIZONTAL DISPLAY MAIN
 - VERTICAL DISPLAY A
 - INT TRIGGER INT
 - DC
 - +SLOPE
 - AUTO
 - TIME/DIV 10 ns/div.
4. Adjust the Channel A VERTICAL POSITION control to center the trace of the 1725A screen.
5. Set the 1725A Channel A input to 50 Ω . The 1725A is used to adjust the 8082A output. Measurement should be made with the 182C/1810A 1 GHz scope.
6. Adjust the 8082A AMPLITUDE VERNIER and OFFSET VERNIER controls to give a waveform from -0.9 volt to +0.9 volt (-1.8 cm to +1.8 cm) on the 1725A screen (as referenced to the zero center line). The pulse width should be about 15 ns, with an approximate repetition rate of 4.5 MHz.
7. Connect a BNC cable from the 8082A TRIG OUT to the 1810A TRIG IN.
8. Connect a BNC cable from the 5370B 10 MHz FREQ STD OUTPUT (rear panel) to the 8082A EXT INPUT.
9. Connect a BNC cable from 8082A OUTPUT/OUTPUT to the 5370B START input.
10. Connect a BNC to SMC cable to A22J7 (START TEST) of the A22 Arming Board. Connect the other end of this cable to Channel A of the 1810A plug-in.
11. Use another BNC to SMC cable to connect A22J8 (STOP TEST) to Channel B of the 1810A plug-in.
12. Set the 1810A Sampling plug-in controls as follows:
 - DISPLAY ALT
 - A TRIG
 - POLARITY +UP (both channels)
 - GAIN 20 mV/cm (both channels)
 - TIME DIV EXPANDED
 - 2 ns/cm
 - TRIGGER NORM
 - +SLOPE
 - EXT
 - SCAN SWEEP

13. Set the 5370B controls as follows:
LINEON
FUNCTION T.I.
STATISTICS MEAN
SAMPLE SIZE..... 1K
ARMING \pm T.I.
INPUTS50 Ω (both channels)
.....+1 (both channels)
..... DC (both channels)
..... +SLOPE (both channels)
..... START COM
LEVEL..... PRESET (both channels)
14. Move the 8082A trigger switch from NORM to EXT TRIG and adjust the EXT INPUT LEVEL control to midrange (0 volts). The output of the 8082A will change to have a repetition rate of 10 MHz (triggered by the 5370B clock).
15. Adjust the 1810A plug-in TRIGGER LEVEL control to sync the two traces.
16. Adjust the PULSE WIDTH control of the 8082A to give an 18 ns width of the positive half of the pulse waveforms, on the 182C screen (measure at the 50% points of the pulse edges).
17. Adjust both the 1810A VERTICAL POSITION controls so both traces are centered on the screen.
18. Set 1810A MODE control A, A TRIG.
19. Toggle SLOPE switch SA (START) up and down and observe that the midpoints of the waveforms move $\leq \pm 100$ ps (see figure below).

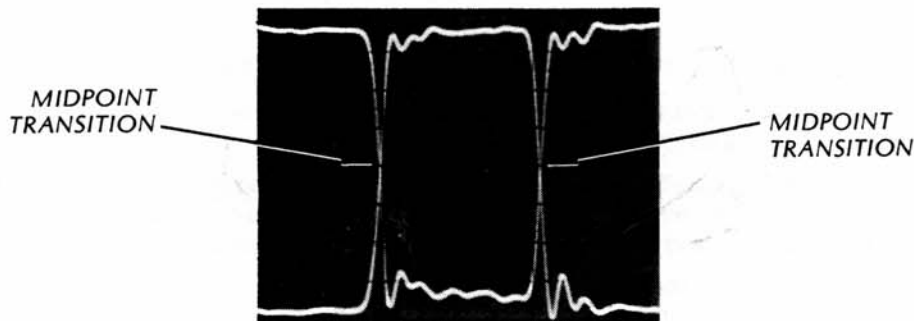

If the midpoints movement are $> \pm 100$ ps, adjust A3R41 to bring within specification.

20. Set 1810A MODE control to B, B TRIG.
21. Toggle SLOPE switch SO (STOP) up and down and observe that the midpoints of the waveforms move $\leq \pm 100$. If the midpoints movement are $> \pm 100$ ps, adjust A3R3 to bring within specification.
22. Set 1810A MODE control to ALT to display both channels A and B.
23. Observe that the START signal waveform on Channel A has a risetime of ≤ 1 ns at 10% to 90% of peak amplitude; if not, adjust A4R11.
24. Observe that the STOP signal waveform on Channel B has a risetime of ≤ 1 ns at 10% to 90% of peak amplitude; if not, adjust A4R12.
25. Observe that the pulses have the same amplitude, and the START signal (1810A Channel A) leads the STOP signal (1810A Channel B) by 800 ps, TYPICAL. In no case should this time difference be greater than 1.8 ns.

Adjustments for the A3/A4 assemblies are now complete.

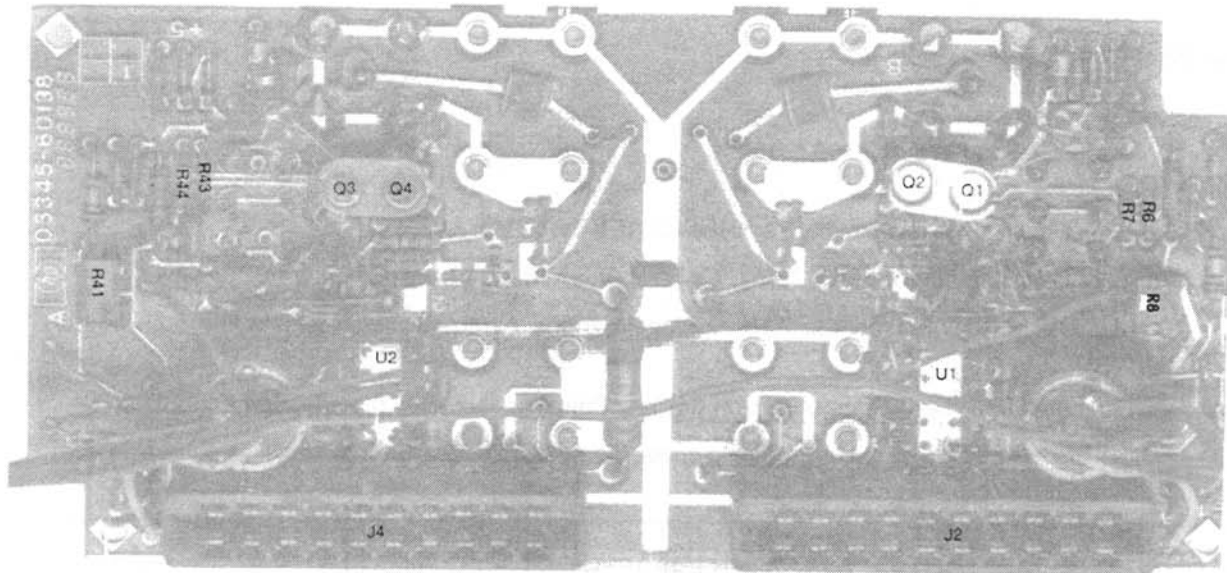

A3 Adjustment Locator

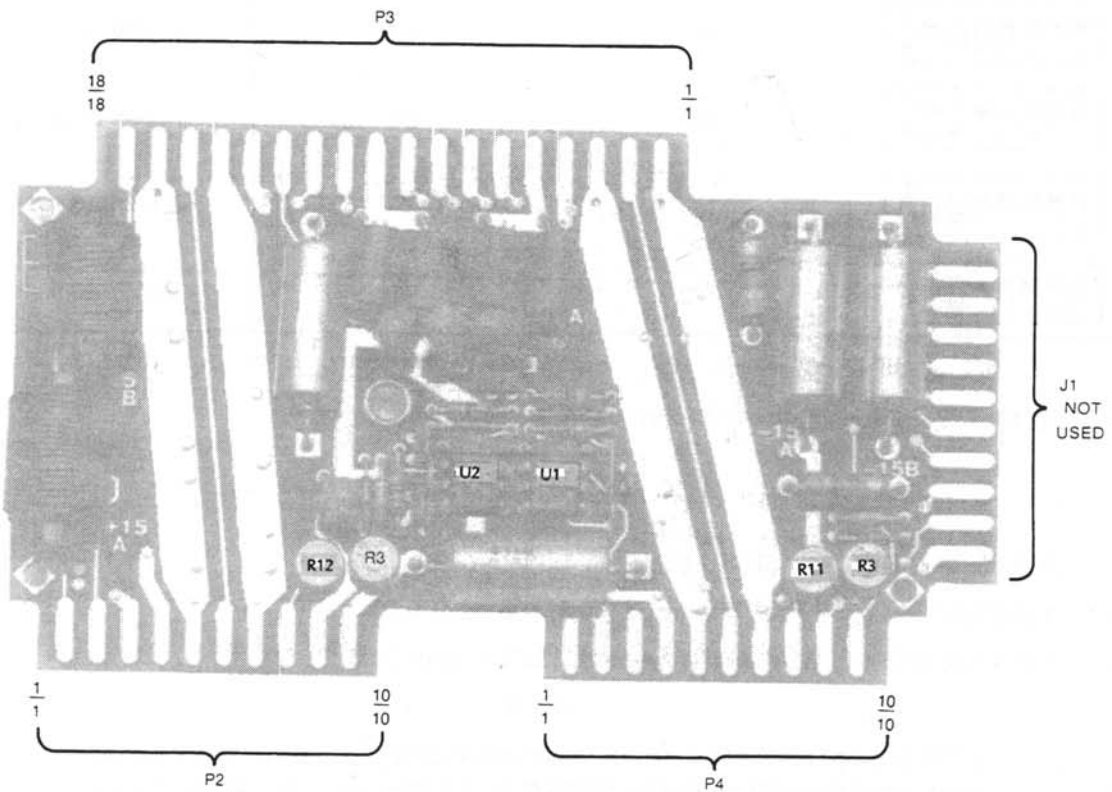

A4 Adjustment Locator

Table 5-2. A18 DAC N0 Logic Assembly

Equipment







HP 3435A DMM

Accessories:

Ceramic Tuning Wand

Setup:

1. Set the 3435A FUNCTION to Vdc and the RANGE to AUTO.
2. Turn the power switch of the 5370B to ON and press TRIG LVL function.
3. Set the DIP test switch on the A16 Arming Interface Assembly as shown in the adjustment hookup.
4. Connect the DMM between ground and the Test Points as shown in the adjustment hookup.
5. Adjust the specified pot on the A18 to meet the specified test limit voltage as shown in the adjustment hookup.

Set Test Switch	Connect DMM	Adjust Pot	Test Limit
	TP2	OO	0.000V ±0.005V
	TP3	OA	0.000V ±0.005V
	TP3	GA	-2.200V ±0.005V
	TP2	GO	-2.200V ±0.005V
	TP3	RA	+2.200V ±0.005V
	TP2	RO	+2.200V ±0.005V

6. Set the DIP test switch on the A16 assembly as shown here.



7. Set both the START and STOP LEVEL controls to PRESET.
8. Adjust pot OA until the left display on the 5370B reads 0.00.
9. Adjust pot OO until the right display on the 5370B reads 0.00.

NOTE

If OA and/or OO (Steps 8 and/or 9) are adjusted to give a display of 0.00, all other previous voltages will be different by the amount shown in the display just before step 8.

Adjustments for the A18 assembly are now complete.

NOTE

The A19 Assembly and the A20 Assembly are the same assembly board with the same HP Part Number. This procedure applies to both.

Equipment:

HP 8082A Pulse Generator
HP 1725A Oscilloscope

Accessories:

HP 10013 10:1 Scope Probe (2 each)
HP 05370-60077 Extender Board (for servicing)
HP 10503-6001 4-foot BNC Cable (2 each)

NOTE

An Adjustment locator for the A19/A20 assembly is located at the end of this table.

Setup:

A19/A20 Assembly

Anticoincidence Pot (R5).....to midrange
Symmetry Pot (R16).....to midrange
Balance Pot (R69).....to midrange
T.I. Zero Varcap (C3)..... to minimum C
(Silver semicircle away from delay line and slightly to board)

Pulse Generator

AMPLITUDE..... 1.0 to 1.0 volt range
POLARITY.....Negative
..... Complement
OFFSETto ON
DELAY to DELAY
..... 2 ns to 5 ns range
DELAY VERNIER minimum (CCW)
WIDTH to 5-50 ns range
WIDTH VERNIERto midrange
PERIOD..... to 0.1 μ to 1 μ
PERIOD VERNIER.....to midrange
TRIGGER..... to NORM

1725A Oscilloscope

CHANNEL A to GND
..... to 0.5V/cm
CHANNEL B..... to DC
..... to 0.05V/cm
HORIZONTAL DISPLAY to MAIN
VERTICAL DISPLAY to A
INT TRIGGER..... to A
MAIN TRIGGER AUTO
..... +
..... DC
.....INT
HORIZONTAL TIME/DIV to 10 ns/div

1. Center Channels A and B scope traces to midscreen.
2. Set channels (scope) to 50 Ω .
3. Connect BNC cable between pulse generator Channel A output and 1725A Channel A input.
4. Adjust pulse generator amplitude vernier and offset vernier to give a waveform from -2 cm to 2 cm on screen (-1V to +1V). DO NOT ADJUST SCOPE VERTICAL POSITION!
5. Connect the BNC cable from pulse generator Channel A output to 5370B START input.
6. Connect a BNC cable from the 5370B rear panel 10 MHz Output to pulse generator EXT TRIGGER INPUT.

Table 5-3. A19/A20 Interpolator Assembly (Continued)

Setup:

1725A Oscilloscope
 VERTICAL DISPLAY ALT
 CHANNEL DC
 0.05V/div
 TIME/DIV MAIN 0.2 μ /div
 DELAYED 10 ns/div

5370B Inputs
 BOTH CHANNELS 50 Ω
 +1
 DC
 +SLOPE
 START COM
 TRIGGER LEVELS PRESET
 DISPLAY RATE maximum (cw)

7. With both Interpolator Assemblies (A19/A20) installed in 5370B, set 5370B line switch ON.
8. Set pulse generator Trigger Select to EXT TRIG.
9. Adjust pulse generator EXTERNAL INPUT TRIGGER LEVEL fully clockwise (disable trigger).
10. Connect scope probe A to TP10 and scope probe B to TP11 of interpolator board being adjusted.
11. Adjust scope waveforms to overlay each other.
12. Adjust balance Pot R69 so the positive edge of Channel A (oscilloscope) coincides with the positive edge of Channel B as shown in the right photo below:

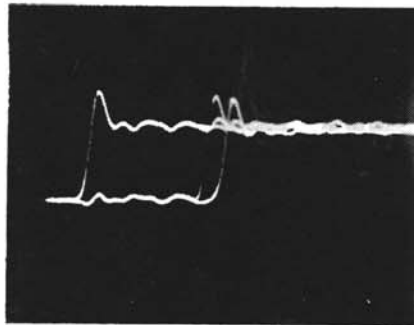

INCORRECTLY ADJUSTED R69

BOTH POSITIVE EDGES COINCIDE

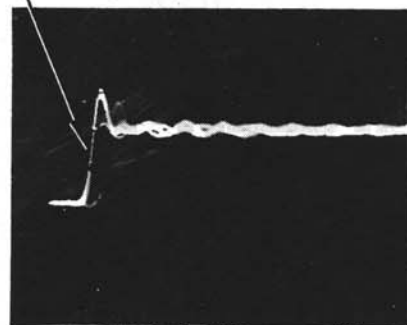

CORRECTLY ADJUSTED R69

13. Adjust symmetry pot R16 so the negative edges of Channel A (oscilloscope) and Channel B coincide as shown in the right photo below.

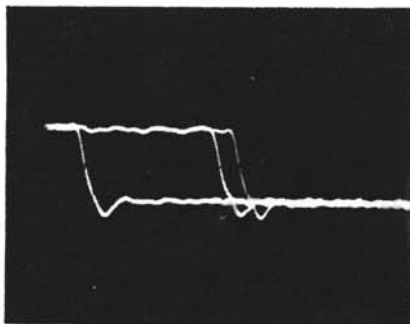

INCORRECTLY ADJUSTED R16

BOTH NEGATIVE EDGES COINCIDE

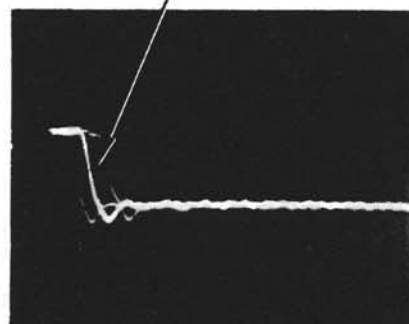

CORRECTLY ADJUSTED R16

14. Connect scope probe A to A19TP10 and probe B to A20TP10.
15. Press SAMPLE SIZE 10K and \pm T.I. (ARMING) on the front panel of the 5370B.
16. Adjust the pulse generator Trigger Level Control to midrange (0V). Set the oscilloscope HORIZONTAL DISPLAY to MAIN.

NOTE

Adjust only one capacitor (START or STOP). The other capacitor should be at minimum.

17. Adjust the T.I. Zero variable capacitor (C3) in either the START (A19) or the STOP (A20) interpolator, whichever is necessary, to align the two traces on the oscilloscope.

NOTE

The next adjustment must be made AFTER T.I. Zero adjustment and should be made each time T.I. Zero is changed.

18. Connect scope probe A to TP3 and probe B to TP10 of interpolator board under adjustment. Set the switch (on the A16 assembly) closest to the front of the 5370B down. The switch array from front to back should now be

This end toward front panel → 

NOTE

Channel A should display a positive pulse and Channel B should display a square wave.

19. Adjust the pulse generator's Delay Vernier slowly until the first positive edge of the square wave comes as close to the negative edge of the pulse as possible as shown below.

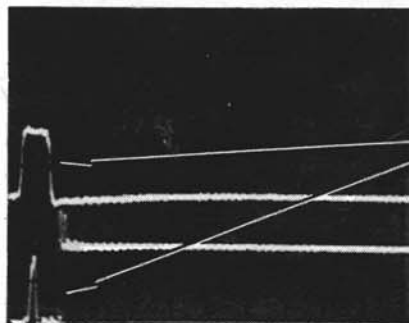

ADJUST PULSE GENERATOR
TO ALIGN THESE EDGES

PULSE SQUARE WAVE ALIGNMENT

NOTE

Ideal when the first positive half cycle flips in and out of view at random.

20. Set the oscilloscope sweep to 10 ns/div.
21. Adjust the Anticoincidence pot R5 slowly counter-clockwise increasing Channel A pulse width. The first positive slope on the B Channel waveform should fuzz just before the disappearance. Adjust the pot where the fuzz is most pronounced. If adjustment will not cause B Channel waveform to fuzz; recenter pot R5 and adjust pulse generator PULSE DELAY VERNIER to move B Channel positive edge as close to A Channel negative edge as possible. Repeat step 22. Because of drift in the test equipment, this step may have to be repeated.

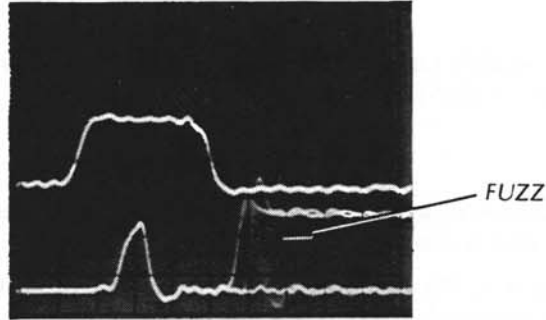

CORRECTLY ADJUSTED R5 (ANTICOINCIDENCE)

22. Adjust oscilloscope Channel A vertical position to center Channel A trace. Adjust Channel B vertical position to move Channel B waveform out of the way. Adjust oscilloscope horizontal position so the center of the negative edge of Channel A waveform is on the center of the scope grid.
23. Adjust Anticoincidence pot R5 to INCREASE pulse width by 2.25 ns as shown below. BE ACCURATE!

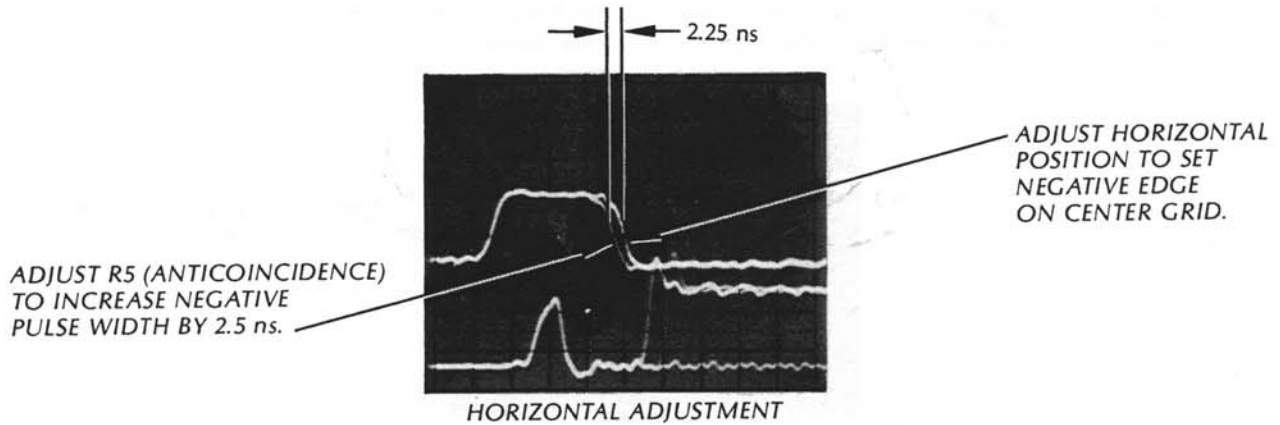

NOTE

If pot runs out of range before 2.25 ns increase can be reached, return the negative edge to the center grid and then DECREASE pulse width by 2.25 ns (from center grid). BE ACCURATE!

Adjustments for the 05370-60119 Interpolator Assembly are now complete.

Table 5-3. A19/A20 Interpolator Assembly (Continued)

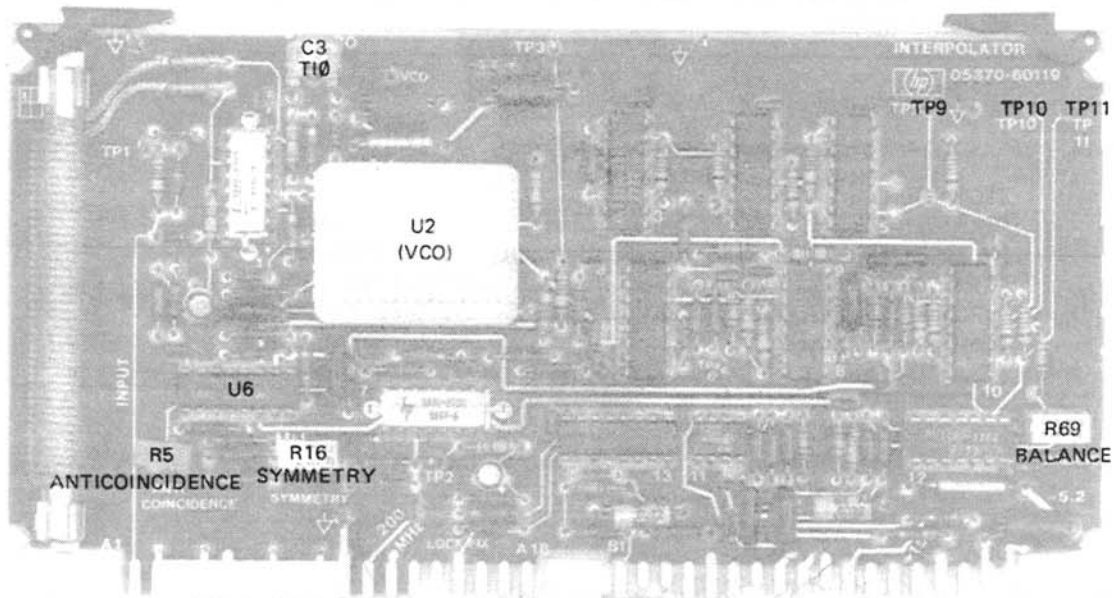

A19/A20 Adjustment Locator

Equipment:

- HP 141T/8552A/8554L Spectrum Analyzer
- HP 1120A Active Probe
- HP 1122A Probe Power Supply

Accessories:

- HP 10241A 10:1 Divider Tip
- HP 5060-0404 Spanner Tip
- HP 8710-0033 Ceramic Tuning Wand
- 12-in. Alligator Clip Lead

Setup:

1. Connect 10:1 divider tip and spanner tip to active probe. Connect probe to power supply.

CAUTION

Always set 5370B power to STBY before removing or inserting assembly boards.

2. Remove A19 and A20 assemblies.
3. Set 141T/8552A/8554L Spectrum Analyzer as follows:

STORAGE	STD
PERSISTENCE	MIN
BANDWIDTH	100 kHz
SCAN WIDTH	10 MHz PER DIV
INPUT ATTENUATOR.....	10 dB
CENTER FREQUENCY.....	50 MHz
SCAN TIME	2 ms
LOG REF LEVEL DIAL	-10 dBm
LOG REF LEVEL VERNIER	0
LOG REF LEVEL SWITCH	LOG
VIDEO FILTER SWITCH	OFF
SCAN MODE SWITCH.....	INT
SCAN TRIGGER SWITCH.....	AUTO

4. Connect HP 1120A Active Probe to spectrum analyzer RF INPUT.
5. Connect probe tip to A21TP3.

NOTE

Make all the following adjustments with ceramic tuning wand only.

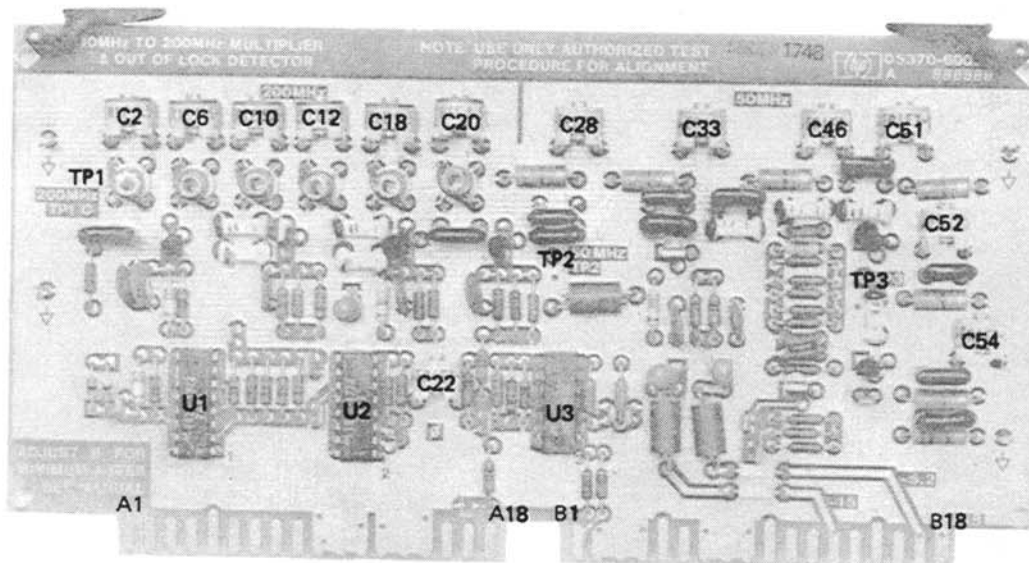

6. Adjust A21C54 for equal amplitude of the 40 MHz and 60 MHz sidebands around the 50 MHz center frequency as shown. Do not readjust C54 during the remaining procedure.

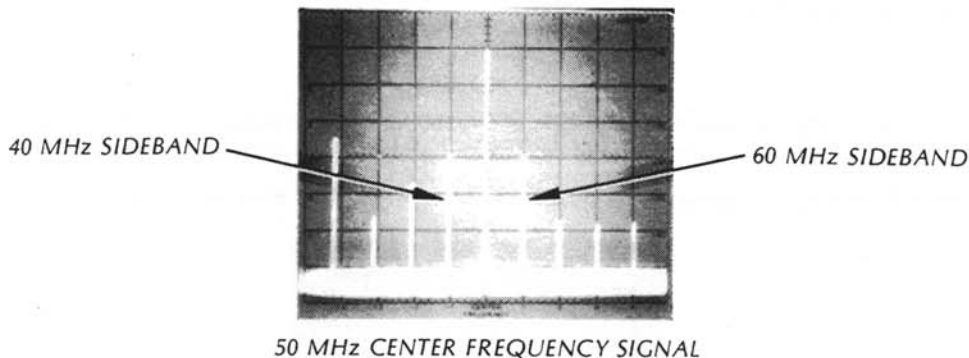

7. Set spectrum analyzer input attenuator to 20 dB and connect probe tip to A21TP2.
8. Adjust A21C52, C51, C46, C33, and C28 to minimize all sidebands around the 50 MHz signal as completely as possible. Repeat adjustment as necessary until sidebands are down 60 dB or more as shown.

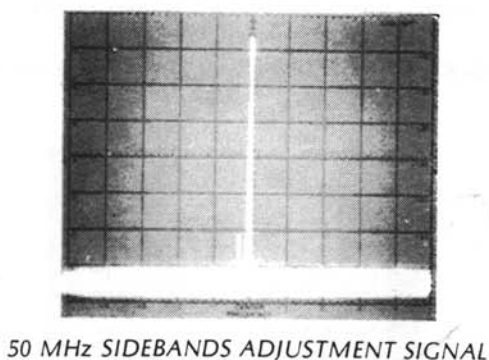

9. Set spectrum analyzer as follows:
 - CENTER FREQUENCY200 MHz
 - BANDWIDTH 300 kHz
 - SCAN WIDTH50 MHz/div
 - LOG REF LEVEL DIAL +10 dBm
10. Connect probe tip to A21TP1. Make sure the probe is grounded. The probe ground connection is critical. Poor ground will give excessive 10 MHz frequency components.
11. Adjust A21C20, C18, C12, C10, C6, and C2 to the prealignment position ("silvered" half of each capacitor adjacent to board ground plane) as shown.

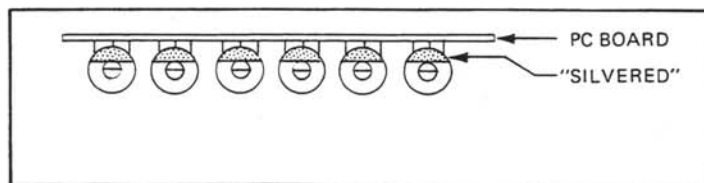

CAPACITOR PREALIGNMENT POSITION

12. Adjust A21C20, C18, C12, C10, C6, and C2 to maximize the amplitude of the 200 MHz center frequency signal.
13. Readjust A21C20, C18, C12, C10, C6, and C2 to minimize all sidebands around the 200 MHz center frequency as completely as possible.

NOTE

Maintaining the maximum amplitude of the 200 MHz center frequency is not critical at this point and the amplitude of the second harmonic (400 MHz) is not critical.

14. Repeat adjustments as necessary until sidebands are down 65 dB or more as shown.

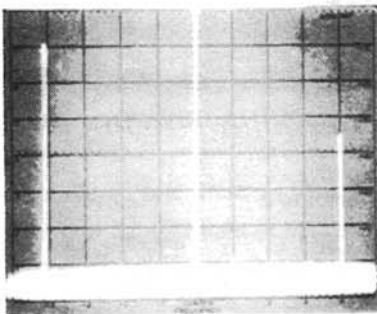

200 MHz SIDE BAND ADJUSTMENT SIGNAL

15. Set spectrum analyzer LOG REF LEVEL VERNIER for 200 MHz center frequency at 0 dB log reference level on display screen.

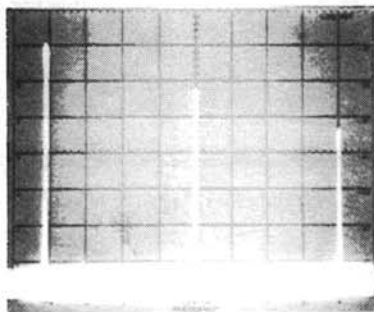

200 MHz TEST LIMIT SIGNAL

Test Limit

16. Connect probe tip to U1 pin 2 and observe 200 MHz signal amplitude down less than 30 dB.
17. Connect probe tip to U1 pin 14 and observe 200 MHz signal amplitude down less than 30 dB.
18. Connect probe tip to U2 pin 14 and observe 200 MHz signal amplitude down less than 30 dB.

Adjustments for the A21 Multiplier assembly are now complete.

Table 5-5. A22 Arming Board Removal

To remove the arming board from the 5370B, use the following procedure:

1. Remove top and bottom covers.
2. Remove the two ribbon cables and the three coax cables from the A22 assembly. (Two of these are removed from bottom of instrument).
3. Lift the arming board by its left side and by its right side using the J3 connector socket until the board just clears the top of its motherboard connector.
4. Push the arming board back and down so that its edge connector rests flush against the back side of the motherboard connector.
5. Hold the left corner of the A4 Interconnect board and push the arming board near its J2 connector until the two connectors pull free.
6. Free the left edge of the arming board from its edge support and slide the board to the left to remove from the counter.

Table 5-6. A22 Arming Board Installation

To install the arming board from the 5370B, use the following procedure:

1. Remove the A20 and A21 boards from the counter to allow additional room to work.
2. Lower the arming board into position so that its edge connector rests on top of the motherboard connector and A22J2 rests on top of the A4 board edge connector. The arming board will have to be tilted slightly so that the A4 edge connector can slip between A22J2 and the transistors and coax connectors just below it.
3. Insert the left edge of the arming board into its edge support, and ensure it remains in the support throughout steps 4, 5, and 6.
4. Hold the left corner of the A4 Interconnect board, and push the arming board near its J2 connector until A22J2 and A4 edge connector can be maneuvered into their mating positions.
5. From the back side of A22, push the arming board forward until it mates securely to A4. Be sure the A22 edge connector is raised above the motherboard connector or the two boards will not be able to mate.
6. Insert A22 into its motherboard connector.
7. Install A19, A20, the two ribbon cables, and the three coax cables. Replace covers.

NOTE

Removal of the A22 Assembly is not normally necessary for adjustment. However, *Table 5-5* and *5-6* are given in case removal of the A22 Assembly is desired.

Equipment:

HP 10503A Coaxial Cable.

Setup:

1. Set 5370B controls as follows:

FUNCTION T.I.
STATISTICS MEAN
SAMPLE SIZE 1
ARMING +T.I. ONLY
START/STOP LEVELS PRESET
IMPEDANCE 50Ω
ATTENUATORS ÷1
INPUT COUPLINGS DC
SEP/COM START COM

2. Adjust pots A22R63 and A22R65 fully clockwise.
3. Connect the coaxial cable between the rear panel FREQ STD OUTPUT jack and the front panel START input jack. Display should indicate 100.00 ns ±0.7 ns.

NOTE

Adjustment loop starts here.

Adjustment:

1. Set 5370B controls as follows:

FUNCTION PERIOD
STATISTICS MEAN
SAMPLE SIZE 1K

Test Limit: 5370B display should indicate 100.00 ns ±0.01 ns.

NOTE

No change in reading will occur until the complete procedure has been followed.

2. Adjust pot A22R65 slightly if display reads high.
3. Adjust pot A22R63 slightly if display reads low.

NOTE

Once beginning adjustment, always adjust same pot.

4. Set 5370B FUNCTION to T.I.
5. Perform step 1.

NOTE

If reading in step 1 is not within specifications, repeat steps 1 through 5.

Adjustments for the A22 Arming Assembly are now complete.

Every few months, the oscillator should be checked to a house standard. When adjustment is required, use the oscilloscope method shown below. Using the appropriate sweep speed, adjust the oscillator until the movement of the pattern is stopped.

NOTE

The 5370B counter should be connected to the ac supply for at least one hour prior to oscillator frequency/adjustment. This ensure the 10811-60111 is at operating temperature.

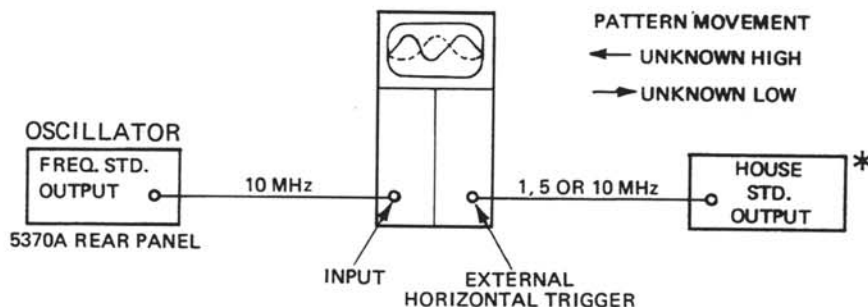

OSCILLATOR ADJUSTMENT INTERCONNECTIONS

MOVEMENT	SWEEP SPEED			NOTES
	1 μ s/cm	0.1 μ s/cm	0.01 μ s/cm	
1 cm/s	1×10^{-6}	1×10^{-7}	1×10^{-8}	Time scope trace movement with second hand of watch or clock.
1 cm/10 s	1×10^{-7}	1×10^{-8}	1×10^{-9}	
1 cm/100 s	1×10^{-8}	1×10^{-9}	1×10^{-10}	

Sweep movement versus calibration accuracy.

Adjustments for the A69 Oscillator are now complete.

*House standard accuracy must be greater than 5×10^{-10} /day

SECTION VI REPLACEABLE PARTS

6-1. INTRODUCTION

6-2. This chapter contains information for ordering parts. The following replaceable parts lists are included.

Table 6-1	Reference Designations and Abbreviations
Table 6-2	Replaceable Parts
Table 6-3	Manufacturer's Codes

6-3. REFERENCE DESIGNATIONS

6-4. *Table 6-1* lists the abbreviations and reference designations used in the parts lists, block diagrams, and throughout the manual.

6-5. REPLACEABLE PARTS

6-6. Table 6-2 is the list of replaceable parts and is organized as follows:

1. Electrical assemblies in alphanumerical order by reference designation.
2. Chassis-mounted electrical parts in alphanumerical order by reference designation.
3. Chassis-mounted mechanical parts in alphanumerical order by reference designation.

6-7. The information given for each part consists of the following:

1. Reference Designation
2. Hewlett-Packard part number.
3. Part number check digit (CD).
4. Total quantity (QTY) in instrument. The total quantity is given once and at the first appearance of the part number in the list.
5. Description of the part.
6. Typical manufacturer's part number for the part.

6-8. HOW TO ORDER A PART

6-9. Hewlett-Packard wants to keep your parts ordering process as simple and efficient as possible. Think of the process as having the following steps:

- Identifying the part and the quantity that you want.
- Determining the ordering method to be used and contacting Hewlett-Packard.

6-10. Parts Identification

6-11. To identify the part(s) you want, first refer to the replaceable parts lists (*Table 6-2*) in this chapter.

6-12. When ordering from Hewlett-Packard, the important numbers to note from the Parts List are the HP Part Number and part-number check digit (in the "CD" column), and the quantity of the part you want.

6-13. If the part you want is NOT identified in the manual, you can call on Hewlett-Packard for help (see the following section ("Contacting Hewlett-Packard"). Please have the following information at hand when you contact HP for help:

- Instrument Model Number (example "HP 5370B").
- Complete instrument Serial Number (example "1234A56789"). Information about where to find the serial number is given in the preface of this manual in the "HOW TO USE THIS MANUAL" section.
- Description of the part and its use.
- Quantity of the part required.

6-14. Contacting Hewlett-Packard

6-15. Depending on where you are in the world, there are one or more ways in which you can get parts or parts information from Hewlett-Packard.

- Outside the United States, contact your local HP sales office. HP sales offices are listed at the back of this manual.
- Within the United States, we encourage you to order replacement parts or request parts information directly by telephone or mail from the HP Support Materials Organization, using the telephone numbers or address listed below. (You can also contact your local HP sales office. HP sales offices are listed at the back of this manual.)

6-16. By telephone:

- a. For Parts Ordering, use our toll-free number (800) 227-8164, Monday through Friday (except Holidays), 6 am to 5 pm (Pacific Time).
- b. If you need a part in a hurry, an extra-cost Hotline phone ordering service is available, 24 hours a day. Use the toll free number above at the times indicated; at other times, use (916) 785-8460.
- c. For Parts Identification Assistance, call us at (916) 783-0804. Our Parts Identification hours are from Monday through Friday, 6 am to 5 pm (Pacific Time).

6-17. For mail correspondence, use the address below:

Hewlett-Packard
Support Materials Roseville
P.O. Box 1145
Roseville, Ca 95661-1145

6-18. CABINET PARTS AND HARDWARE:

6-19. To locate and identify miscellaneous cabinet parts, refer to *Figure 6-1*. This figure provides an exploded view of the cabinet, with the parts identified by reference designations; the reference designations correspond with the ones in *Table 6-3*.

Table 6-1. Reference Designations and Abbreviations

REFERENCE DESIGNATIONS			
A	= assembly	DL	= delay line
AT	= attenuator, isolator termination	DS	= annunciator, signaling device (audible or visual); lamp; LED
B	= fan; motor	E	= miscellaneous electrical part
BT	= battery	F	= fuse
C	= capacitor	FL	= filter
CP	= coupler	H	= hardware
CR	= diode, diode thyristor varactor	HY	= circulator
DC	= directional coupler	J	= electrical connector; (stationary portion); jack
K	= relay	L	= coil, inductor
M	= metre	MP	= miscellaneous mechanical part
P	= electrical connector (movable portion); plug	Q	= transistor; SCR; triode thyristor
R	= resistor	RT	= thermistor
S	= switch	T	= transformer
TC	= thermocouple	TB	= terminal board
TP	= test point	TC	= thermocouple
U	= integrated circuit; microcircuit	TP	= test point
V	= electron tube	U	= integrated circuit; microcircuit
VR	= voltage regulator; breakdown diode	V	= electron tube
W	= cable; transmission path; wire	VR	= voltage regulator; breakdown diode
X	= socket	W	= cable; transmission path; wire
Y	= crystal unit-piezo-electric	X	= socket
Z	= tuned cavity; tuned circuit	Y	= crystal unit-piezo-electric
		Z	= tuned cavity; tuned circuit

ABBREVIATIONS			
A	= ampere	HD	= head
ac	= alternating current	HDW	= hardware
ACCESS	= accessory	HF	= high frequency
A/D	= analog-to-digital	HI	= high
AF	= audio frequency	HP	= Hewlett-Packard
AFC	= automatic frequency control	HPF	= high pass filter
AGC	= automatic gain control	HR	= hour (used in parts list)
AL	= aluminum	HV	= high voltage
ALC	= automatic level control	Hz	= hertz
AM	= amplitude modulation	IC	= integrated circuit
AMPL	= amplifier	ID	= inside diameter
APC	= automatic phase control	IF	= intermediate frequency
ASSY	= assembly	IMPG	= impregnated
AUX	= auxiliary	in	= inch
AVG	= average	INCD	= incandescent
AWG	= American wire gage	INCL	= include(s)
BAL	= balance	INP	= input
BCD	= binary coded decimal	INS	= insulation
BD	= board	INT	= internal
BE CU	= beryllium copper	kg	= kilogram
BFO	= beat frequency oscillator	kHz	= kilohertz
BH	= binder head	kΩ	= kilohm
BKDN	= breakdown	kV	= kilovolt
BP	= bandpass	lb	= pound
BPF	= bandpass filter	LC	= inductance-capacitance
BRS	= brass	LED	= light-emitting diode
BWO	= backward-wave oscillator	LF	= low frequency
CAL	= calibrate	LG	= long
ccw	= counterclockwise	LH	= left hand
CER	= ceramic	LIM	= limit
CHAN	= channel	LIN	= linear taper (used in parts list)
cm	= centimeter	lin	= linear
CMO	= coaxial	LK WASH	= lockwasher
COEF	= coefficient	LO	= low; local oscillator
COM	= common	LOG	= logarithmic taper (used in parts list)
COMP	= composition	log	= logarithmic
COMPL	= complete	LPF	= low pass filter
CONN	= connector	LV	= low voltage
CP	= cadmium plate	m	= metre (distance)
CRT	= cathode-ray tube	mA	= milliampere
CTL	= complementary transistor logic	MAX	= maximum
CW	= continuous wave	MΩ	= megohm
cw	= clockwise	MEG	= meg (10 ⁶) (used in parts list)
D/A	= digital-to-analog	MET FLM	= metal film
dB	= decibel	MET OX	= metal oxide
dBm	= decibel referred to 1mW	MF	= medium frequency; microfarad (used in parts list)
dc	= direct current	MFR	= manufacturer
deg	= degree (temperature interval (or difference)	mg	= milligram
...	= degree (plane angle)	MHz	= megahertz
°C	= degree Celsius (centigrade)	mH	= millihenry
°F	= degree Fahrenheit	mho	= conductance
6K	= degree Kelvin	MIN	= minimum
DEPC	= deposited carbon	min	= minute (time)
DET	= detector	...	= minute (plane angle)
diam	= diameter	MINAT	= miniature
DIA	= diameter (used in parts list)	mm	= millimetre
DIFF AMPL	= differential amplifier	MOD	= modulator
div	= division	MOM	= momentary
DPDT	= double-pole, double-throw	MOS	= metal-oxide semiconductor
DR	= drive	ms	= millisecond
DSB	= double sideband	MTG	= mounting
DTL	= diode transistor logic	MTR	= meter (indicating device)
DVM	= digital voltmeter	mV	= millivolt
ECL	= emitter coupled logic	mVac	= millivolt, ac
EMF	= electromotive force	mVdc	= millivolt, dc
EDP	= electronic data processing	mVpk	= millivolt, peak
ELECT	= electrolytic	mVp-p	= millivolt, peak-to-peak
ENCAP	= encapsulated	mVrms	= millivolt, rms
EXT	= external	mW	= milliwatt
F	= farad	MUX	= multiplex
FET	= field-effect transistor	MY	= mylar
F/F	= flip-flop	μA	= microampere
FH	= flat head	μF	= microfarad
FOL.H	= fillister head	μH	= microhenry
FM	= frequency modulation	μmho	= micromho
FP	= front panel	μs	= microsecond
FREQ	= frequency	μV	= microvolt
FXD	= fixed	μVac	= microvolt, ac
g	= gram	μVdc	= microvolt, dc
GE	= germanium	μVpk	= microvolt, peak
GHz	= gigahertz	μVp-p	= microvolt, peak-to-peak
GL	= glass	μVrms	= microvolt, rms
GND	= ground(ed)	μW	= microwatt
H	= henry	nA	= nanoampere
h	= hour	NC	= no connection
HET	= heterodyne	N/C	= normally closed
HEX	= hexagonal		

MULTIPLIERS			
Abbreviation	Prefix	Multiple	
T	tera	10 ¹²	
G	giga	10 ⁹	
M	mega	10 ⁶	
k	kilo	10 ³	
da	deka	10	
d	deci	10 ⁻¹	
c	centi	10 ⁻²	
m	milli	10 ⁻³	
μ	micro	10 ⁻⁶	
n	nano	10 ⁻⁹	
p	pico	10 ⁻¹²	
f	femto	10 ⁻¹⁵	
a	atto	10 ⁻¹⁸	

NOTE
All abbreviations in the parts list will be in upper case.

Table 6-2. Replaceable Parts

Reference Designation	HP Part Number	C D	Qty	Description	Mfr Code	Mfr Part Number
A1	05370-60080	5	1	BOARD ASSEMBLY- MOTHER/POWER SUPPLY (SERIES 2552)	28480	05370-60080
A1C1	0180-2800	4	2	CAPACITOR-FXD .01F+75-10% 40VDC AL	28480	0180-2800
A1C2	0180-2799	0	2	CAPACITOR-FXD .017F+75-10% 20VDC AL	28480	0180-2799
A1C3	0180-2799	0		CAPACITOR-FXD .017F+75-10% 20VDC AL	28480	0180-2799
A1C4	0180-2800	4		CAPACITOR-FXD .01F+75-10% 40VDC AL	28480	0180-2800
A1H1 - H2	1530-1098	4	2	CLEVIS 0.070-IN W SLT: 0.454-IN PIN CTR	00000	ORDER BY DESCRIPTION
A1J1	1251-0493	9	1	CONNECTOR-PC EDGE 6-CONT/ROW 2-ROWS	28480	1251-0493
A1MP1 - MP3	0380-0336	1	3	SPACER-RVT-ON .312-IN-LG .152-IN-ID	00000	ORDER BY DESCRIPTION
A1R1	0757-0435	0	2	RESISTOR 3.92K 1% .125W F TC=0+100	24546	C4-1/8-T0-3921-F
A1R2	0757-0283	6	2	RESISTOR 2K 1% .125W F TC=0+100	24546	C4-1/8-T0-2001-F
A1R3	0757-0283	6		RESISTOR 2K 1% .125W F TC=0+100	24546	C4-1/8-T0-2001-F
A1R4	0757-0435	0		RESISTOR 3.92K 1% .125W F TC=0+100	24546	C4-1/8-T0-3921-F
A1XA6	1251-1365	6	1	CONNECTOR-PC EDGE 22-CONT/ROW 2-ROWS	28480	1251-1365
A1XA7	1251-0472	4	1	CONNECTOR-PC EDGE 6-CONT/ROW 2-ROWS	28480	1251-0472
A1XA8	1251-2035	9	2	CONNECTOR-PC EDGE 15-CONT/ROW 2-ROWS	28480	1251-2035
A1XA69	1251-2035	9		CONNECTOR-PC EDGE 15-CONT/ROW 2-ROWS	28480	1251-2035
				A1 MISCELLANEOUS		
	2190-0012	9	8	WASHER-LK EXT T #10	00000	ORDER BY DESCRIPTION
	2680-0129	8	8	SCREW-MACH 10-32 .312-IN-LG PAN HD	00000	ORDER BY DESCRIPTION
	7120-4163	7	1	LABEL- WARNING, VOLTAGE	28480	7120-4163
A2	05370-60102	2	1	BOARD ASSEMBLY- MAIN MOTHER(SERIES 2316)	28480	05370-60102
A2C1 - C3	0180-1701	2	3	CAPACITOR-FXD 6.8UF+20% 6VDC TA	56289	150D685X0006A2
A2J1	1200-0482	9	1	SOCKET-IC 16-CONT DIP-SLDR	28480	1200-0519
A2R1 - R4	0757-0280	3	2	RESISTOR 1K 1% .125W F TC=0+100	24546	C4-1/8-T0-1001-F
A2XA9A	1251-2026	8	16	CONNECTOR-PC EDGE 18-CONT/ROW 2-ROWS	28480	1251-2026
A2XA9B	1251-2026	8		CONNECTOR-PC EDGE 18-CONT/ROW 2-ROWS	28480	1251-2026
A2XA10A/B				NOT ASSIGNED		
A2XA11A	1251-2026	8		CONNECTOR-PC EDGE 18-CONT/ROW 2-ROWS	28480	1251-2026
A2XA11B	1251-2026	8		CONNECTOR-PC EDGE 18-CONT/ROW 2-ROWS	28480	1251-2026
A2XA12A/B				NOT ASSIGNED		
A2XA13A/B				NOT ASSIGNED		
A2XA14A	1251-2026	8		CONNECTOR-PC EDGE 18-CONT/ROW 2-ROWS	28480	1251-2026
A2XA14B	1251-2026	8		CONNECTOR-PC EDGE 18-CONT/ROW 2-ROWS	28480	1251-2026
A2XA15A	1251-2026	8		CONNECTOR-PC EDGE 18-CONT/ROW 2-ROWS	28480	1251-2026
A2XA15B	1251-2026	8		CONNECTOR-PC EDGE 18-CONT/ROW 2-ROWS	28480	1251-2026
A2XA16A	1251-2026	8		CONNECTOR-PC EDGE 18-CONT/ROW 2-ROWS	28480	1251-2026
A2XA16B	1251-2026	8		CONNECTOR-PC EDGE 18-CONT/ROW 2-ROWS	28480	1251-2026
A2XA17A	1251-2026	8		CONNECTOR-PC EDGE 18-CONT/ROW 2-ROWS	28480	1251-2026
A2XA17B	1251-2026	8		CONNECTOR-PC EDGE 18-CONT/ROW 2-ROWS	28480	1251-2026
A2XA18A	1251-2026	8		CONNECTOR-PC EDGE 18-CONT/ROW 2-ROWS	28480	1251-2026
A2XA18B	1251-4940	9	1	CONNECTOR-PC EDGE 2 X 18	28480	1251-4940
A2XA19A	1251-2026	8		CONNECTOR-PC EDGE 18-CONT/ROW 2-ROWS	28480	1251-2026
A2XA19B	1251-4941	0	1	CONNECTOR-PC EDGE 2 X 18	28480	1251-4941
A2XA20A	1251-4939	6	2	CONNECTOR-PC EDGE 2 X 18	28480	1251-4939
A2XA20B	1251-4939	6		CONNECTOR-PC EDGE 2 X 18	28480	1251-4939
A2XA21A	1251-2026	8		CONNECTOR-PC EDGE 18-CONT/ROW 2-ROWS	28480	1251-2026
A2XA21B	1251-2026	8		CONNECTOR-PC EDGE 18-CONT/ROW 2-ROWS	28480	1251-2026
A2XA22	1251-1365	6	1	CONNECTOR-PC EDGE 22-CONT/ROW 2-ROWS	28480	1251-1365

See introduction to this section for ordering information
*Indicates factory selected value

Table 6-2. Replaceable Parts (Continued)

Reference Designation	HP Part Number	C D	Qty	Description	Mfr Code	Mfr Part Number
A3	05345-60138	3	1	BOARD ASSY- INPUT AMPLIFIER (SERIES 2438)	28480	05345-60138
A3C1 - C8	0160-3879	7	32	CAPACITOR-FXD .01UF +-20% 100VDC CER NOT ASSIGNED	28480	0160-3879
A3C9						
A3C10	0150-0072	5	2	CAPACITOR-FXD 200PF +-5% 1KVDC CER	72982	838-X5E-201J-1KV
A3C11 - C15	0160-3879	7		CAPACITOR-FXD .01UF +-20% 100VDC CER	28480	0160-3879
A3C16	0160-6244	6	2	CAPACITOR-FXD 68PF +-1% 350VDC PORC	51406	MA20680F
A3C17	0160-0551	6	2	CAPACITOR-FXD .01UF +-100-0% 400VDC CER	28480	0160-0551
A3C18	0160-5978	1	2	CAPACITOR-FXD 2.2PF +-22.73% 50VDC CER	28480	0160-5978
A3C19				NOT ASSIGNED		
A3C20	0160-3879	7		CAPACITOR-FXD .01UF +-20% 100VDC CER	28480	0160-3879
A3C21				NOT ASSIGNED		
A3C22	0160-0551	6		CAPACITOR-FXD .01UF +-100-0% 400VDC CER	28480	0160-0551
A3C23	0160-5978	1		CAPACITOR-FXD 2.2PF +-22.73% 50VDC CER	28480	0160-5978
A3C24	0160-6244	6		CAPACITOR-FXD 68PF +-1% 350VDC PORC	51406	MA20680F
A3C25	0160-3879	7		CAPACITOR-FXD .01UF +-20% 100VDC CER	28480	0160-3879
A3C26	0160-3879	7		CAPACITOR-FXD .01UF +-20% 100VDC CER	28480	0160-3879
A3C27	0160-3879	7		CAPACITOR-FXD .01UF +-20% 100VDC CER	28480	0160-3879
A3C28				NOT ASSIGNED		
A3C29 - C33	0160-3879	7		CAPACITOR-FXD .01UF +-20% 100VDC CER	28480	0160-3879
A3C34 - C44	0150-0072	5		CAPACITOR-FXD 200PF +-5% 1KVDC CER	72982	838-X5E-201J-1KV
A3C35	0160-3879	7		CAPACITOR-FXD .01UF +-20% 100VDC CER	28480	0160-3879
A3C45	0160-6243	5	2	CAPACITOR-FXD 2PF +-1PF 350VDC PORC	51406	MA202ROB
A3C46	0160-6243	5		CAPACITOR-FXD 2PF +-1PF 350VDC PORC	51406	MA202ROB
A3CR1	1901-0050	3	4	DIODE-SWITCHING 80V 200MA 2NS DO-35	28480	1901-0050
A3CR2	1901-0050	3		DIODE-SWITCHING 80V 200MA 2NS DO-35	28480	1901-0050
A3CR3	1901-0579	1	8	DIODE-SWITCHING 40V 20MA 300NS DO-7	28480	1901-0579
A3CR4	1901-0579	1		DIODE-SWITCHING 40V 20MA 300NS DO-7	28480	1901-0579
A3CR5	1901-0579	1		DIODE-SWITCHING 40V 20MA 300NS DO-7	28480	1901-0579
A3CR6	1901-0579	1		DIODE-SWITCHING 40V 20MA 300NS DO-7	28480	1901-0579
A3CR7	1901-0050	3		DIODE-SWITCHING 80V 200MA 2NS DO-35	28480	1901-0050
A3CR8	1901-0050	3		DIODE-SWITCHING 80V 200MA 2NS DO-35	28480	1901-0050
A3CR9	1901-0579	1		DIODE-SWITCHING 40V 20MA 300NS DO-7	28480	1901-0579
A3CR10	1901-0579	1		DIODE-SWITCHING 40V 20MA 300NS DO-7	28480	1901-0579
A3CR11	1901-0579	1		DIODE-SWITCHING 40V 20MA 300NS DO-7	28480	1901-0579
A3CR12	1901-0579	1		DIODE-SWITCHING 40V 20MA 300NS DO-7	28480	1901-0579
A3CR13				NOT ASSIGNED		
A3CR14	1902-0025	4	2	DIODE-ZNR 10V 5% DO-35 PD=.4W TC=+.06%	28480	1902-0025
A3CR15	1902-0025	4		DIODE-ZNR 10V 5% DO-35 PD=.4W TC=+.06%	28480	1902-0025
A3H1 - H2	0380-0519	2	2	SPACER-RND .125-IN-LG .259-IN-ID	28480	0380-0519
A3J1	1250-1163	0	2	CONNECTOR-RF BNC FEM SGL-HOLE-RR 50-OHM	28480	1250-1163
A3J2	1251-2034	8	2	CONNECTOR-PC EDGE 10-CONT/ROW 2-ROWS	28480	1251-2034
A3J3	1250-1163	0		CONNECTOR-RF BNC FEM SGL-HOLE-RR 50-OHM	28480	1250-1163
A3J4	1251-2034	8		CONNECTOR-PC EDGE 10-CONT/ROW 2-ROWS	28480	1251-2034
A3MP1	5020-3440	7	1	SPRING: DETENT	28480	5020-3440
A3MP2	1460-0603	6	6	WIREFORM MUW	28480	1460-0603
A3MP3	05345-40002	8	4	GUIDE	28480	05345-40002
A3Q1 - Q4	1855-0225	5	4	TRANSISTOR-JFET DUAL N-CHAN D-MODE SI	28480	1855-0225
A3R1	0698-7247	0	2	RESISTOR 2.87K 1% .05W F TC=0+-100	24546	C3-1/8-T0-2871-F
A3R2	0698-7239	0	2	RESISTOR 1.33K 1% .05W F TC=0+-100	24546	C3-1/8-T0-1331-F
A3R3	2100-3947	6	2	RESISTOR-TRMR 10K 5% WW TOP-ADJ 13-TRN	28480	2100-3947
A3R4	0698-8824	1	2	RESISTOR 562K 1% .125W F TC=0+-100	28480	0698-8824
A3R5	0698-7267	4	2	RESISTOR 19.6K 1% .05W F TC=0+-100	24546	C3-1/8-T0-1962-F
A3R6	0698-7233	4	12	RESISTOR 750 1% .05W F TC=0+-100	24546	C3-1/8-T0-750R-F
A3R7	0698-7233	4		RESISTOR 750 1% .05W F TC=0+-100	24546	C3-1/8-T0-750R-F
A3R8	0698-7253	8	4	RESISTOR 5.11K 1% .05W F TC=0+-100	24546	C3-1/8-T0-5111-F
A3R9	0757-0442	9	2	RESISTOR 10K 1% .125W F TC=0+-100	24546	C4-1/8-T0-1002-F
A3R10	0698-7260	7	2	RESISTOR 10K 1% .05W F TC=0+-100	24546	C3-1/8-T0-1002-F

See introduction to this section for ordering information
*Indicates factory selected value

Table 6-2. Replaceable Parts (Continued)

Reference Designation	HP Part Number	C D	Qty	Description	Mfr Code	Mfr Part Number
A3R11	0698-7253	8		RESISTOR 5.11K 1% .05W F TC=0+100	24546	C3-1/8-T0-5111-F
A3R12	2100-3616	6	2	RESISTOR-VAR W/SW 5K 20% LIN SPST-NO	01121	GS1N112S502MZ
A3R13				NOT ASSIGNED		
A3R14	0698-7205	0	2	RESISTOR 51.1 1% .05W F TC=0+100	24546	C3-1/8-T0-51R1-F
A3R15	0698-7233	4		RESISTOR 750 1% .05W F TC=0+100	24546	C3-1/8-T0-750R-F
A3R16	0757-0059	4	2	RESISTOR 1M 1% .5W F TC=0+100	28480	0757-0059
A3R17	0698-7233	4		RESISTOR 750 1% .05W F TC=0+100	24546	C3-1/8-T0-750R-F
A3R18	0698-7233	4		RESISTOR 750 1% .05W F TC=0+100	24546	C3-1/8-T0-750R-F
A3R19	0698-7229	8	2	RESISTOR 511 1% .05W F TC=0+100	24546	C3-1/8-T0-511R-F
A3R20	0698-7233	4		RESISTOR 750 1% .05W F TC=0+100	24546	C3-1/8-T0-750R-F
A3R21	0699-1633	8	2	RESISTOR 300 5% .25W F TC=0+200	28480	0699-1633
A3R22	0699-1634	9	2	RESISTOR 900K 5% .35W F TC=0+350	28480	0699-1634
A3R23	0698-8880	9	2	RESISTOR 100K 5% .15W C TC=0+150	28480	0698-8880
A3R24	0757-0072	1	2	RESISTOR 49.9 1% .5W F TC=0+100	28480	0757-0072
A3R25	0757-0072	1		RESISTOR 49.9 1% .5W F TC=0+100	28480	0757-0072
A3R26	0698-8382	6	1	RESISTOR 25 5% .25W C TC=0+150	28480	0698-8382
A3R27	0698-8880	9		RESISTOR 100K 5% .15W C TC=0+150	28480	0698-8880
A3R28	0699-1634	9		RESISTOR 900K 5% .35W F TC=0+350	28480	0699-1634
A3R29	0699-1633	8		RESISTOR 300 5% .25W F TC=0+200	28480	0699-1633
A3R30	0698-7205	0		RESISTOR 51.1 1% .05W F TC=0+100	24546	C3-1/8-T0-51R1-F
A3R31	0698-7233	4		RESISTOR 750 1% .05W F TC=0+100	24546	C3-1/8-T0-750R-F
A3R32	0698-7233	4		RESISTOR 750 1% .05W F TC=0+100	24546	C3-1/8-T0-750R-F
A3R33	0698-7229	8		RESISTOR 511 1% .05W F TC=0+100	24546	C3-1/8-T0-511R-F
A3R34	0698-7233	4		RESISTOR 750 1% .05W F TC=0+100	24546	C3-1/8-T0-750R-F
A3R35	0698-7233	4		RESISTOR 750 1% .05W F TC=0+100	24546	C3-1/8-T0-750R-F
A3R36	0757-0059	4		RESISTOR 1M 1% .5W F TC=0+100	28480	0757-0059
A3R37				NOT ASSIGNED		
A3R38	2100-3616	6		RESISTOR-VAR W/SW 5K 20% LIN SPST-NO	01121	GS1N112S502MZ
A3R39	0698-7253	8		RESISTOR 5.11K 1% .05W F TC=0+100	24546	C3-1/8-T0-5111-F
A3R40	0757-0442	9		RESISTOR 10K 1% .125W F TC=0+100	24546	C4-1/8-T0-1002-F
A3R41	2100-3947	6		RESISTOR-TRMR 10K 5% WW TOP-ADJ 13-TRN	28480	2100-3947
A3R42	0698-7260	7		RESISTOR 10K 1% .05W F TC=0+100	24546	C3-1/8-T0-1002-F
A3R43	0698-7233	4		RESISTOR 750 1% .05W F TC=0+100	24546	C3-1/8-T0-750R-F
A3R44	0698-7233	4		RESISTOR 750 1% .05W F TC=0+100	24546	C3-1/8-T0-750R-F
A3R45	0698-8824	1		RESISTOR 562K 1% .125W F TC=0+100	28480	0698-8824
A3R46	0698-7253	8		RESISTOR 5.11K 1% .05W F TC=0+100	24546	C3-1/8-T0-5111-F
A3R47	0698-7239	0		RESISTOR 1.33K 1% .05W F TC=0+100	24546	C3-1/8-T0-1331-F
A3R48	0698-7267	4		RESISTOR 19.6K 1% .05W F TC=0+100	24546	C3-1/8-T0-1962-F
A3R49	0698-7247	0		RESISTOR 2.87K 1% .05W F TC=0+100	24546	C3-1/8-T0-2871-F
A3R50	0698-7219	6	2	RESISTOR 196 1% .05W F TC=0+100	24546	C3-1/8-T0-196R-F
A3R51	0698-7219	6		RESISTOR 196 1% .05W F TC=0+100	24546	C3-1/8-T0-196R-F
A3R52	0698-8827	4	2	RESISTOR 1M 1% .125W F TC=0+100	28480	0698-8827
A3R53	0698-8827	4		RESISTOR 1M 1% .125W F TC=0+100	28480	0698-8827
A3R54	0698-7258	3	2	RESISTOR 8.25K 1% .05W F TC=0+100	24546	C3-1/8-T0-8251-F
A3R55	0698-7258	3		RESISTOR 8.25K 1% .05W F TC=0+100	24546	C3-1/8-T0-8251-F
A3R56	0699-1632	7	2	RESISTOR 75 5% .25W F TC=0+200	28480	0699-1632
A3R57	0699-1632	7		RESISTOR 75 5% .25W F TC=0+200	28480	0699-1632
A3S1	3101-2334	6	2	SWITCH-SL DPDT SUBMIN .5A 125VAC/DC PC	28480	3101-2334
A3S2 - S4	05345-60100	9	6	LEVER/SLIDE	28480	05345-60100
A3S5	05345-60101	0	1	SLIDE AY-P.C. SW	28480	05345-60101
A3S6 - S8	05345-60100	9		LEVER/SLIDE	28480	05345-60100
A3S9	3101-2334	6		SWITCH-SL DPDT SUBMIN .5A 125VAC/DC PC	28480	3101-2334
A3U1	5088-7061	8	1	AMP-HYBRID-CH A (STOP CHANNEL)	28480	5088-7061
A3U2	5088-7062	9	1	AMP-HYBRID-CH B (START CHANNEL)	28480	5088-7062
A3W1	8120-2461	5	1	CABLE, 16-COND RIBBON	28480	8120-2461
A3 MISCELLANEOUS						
	1200-0475	0	28	CONNECTOR-SGL CONT SKT .017-IN-BSC-SZ	28480	1200-0475
	05345-20113	0	2	NUT-HEXAGONAL	28480	05345-20113
	0340-0060	4	4	TERMINAL-STUD SPCL-FDTHRU PRESS-MTG	98291	011-6809 000 209
	01801-22301	7	1	HEATSINK	28480	01801-22301

See introduction to this section for ordering information
*Indicates factory selected value

Table 6-2. Replaceable Parts (Continued)

Reference Designation	HP Part Number	C D	Qty	Description	Mfr Code	Mfr Part Number
A4	05345-60124	7	1	BOARD ASSY- INTERCONNECT (SERIES 2332)	28480	05345-60124
A4C1	0180-0098	8	4	CAPACITOR-FXD 100UF+20% 20VDC TA	56289	150D107X0020S2
A4C2	0180-2816	2	4	CAPACITOR-FXD 68UF+20% 10VDC TA	28480	0180-2816
A4C3	0180-0098	8		CAPACITOR-FXD 100UF+20% 20VDC TA	56289	150D107X0020S2
A4C4	0180-2816	2		CAPACITOR-FXD 68UF+20% 10VDC TA	28480	0180-2816
A4C5	0180-2816	2		CAPACITOR-FXD 68UF+20% 10VDC TA	28480	0180-2816
A4C6	0180-2816	2		CAPACITOR-FXD 68UF+20% 10VDC TA	28480	0180-2816
A4C7	0180-0098	8		CAPACITOR-FXD 100UF+20% 20VDC TA	56289	150D107X0020S2
A4C8	0180-0098	8		CAPACITOR-FXD 100UF+20% 20VDC TA	56289	150D107X0020S2
A4C9	0160-3879	7	4	CAPACITOR-FXD .01UF +20% 100VDC CER	28480	0160-3879
A4C10	0160-3879	7		CAPACITOR-FXD .01UF +20% 100VDC CER	28480	0160-3879
A4C11	0160-3879	7		CAPACITOR-FXD .01UF +20% 100VDC CER	28480	0160-3879
A4C12	0160-3879	7		CAPACITOR-FXD .01UF +20% 100VDC CER	28480	0160-3879
A4CR1 - CR4	1901-0460	9	4	DIODE-STABISTOR 30V 150MA DO-7	28480	1901-0460
A4L1 - L2	9100-3060	1	2	INDUCTOR 260UH 15%	28480	9100-3060
A4L3 - L6	9100-1788	6	4	CORE-FERRITE CHOKE-WIDEBAND; IMP:>680	28480	9100-1788
A4L7 - L8	9100-2562	6	2	INDUCTOR RF-CH-MLD 100UH 10%	28480	9100-2562
A4R1	0757-0446	3	4	RESISTOR 15K 1% .125W F TC=0+100	24546	C4-1/8-T0-1502-F
A4R2	0698-7263	0	2	RESISTOR 13.3K 1% .05W F TC=0+100	24546	C3-1/8-T0-1332-F
A4R3	2100-1738	9	2	RESISTOR-TRMR 10K 10% C TOP-ADJ 1-TRN	73138	82PR10K
A4R4	0698-7255	0	2	RESISTOR 6.19K 1% .05W F TC=0+100	24546	C3-1/8-T0-6191-F
A4R5	0757-0446	3		RESISTOR 15K 1% .125W F TC=0+100	24546	C4-1/8-T0-1502-F
A4R6	0698-7263	0		RESISTOR 13.3K 1% .05W F TC=0+100	24546	C3-1/8-T0-1332-F
A4R7	0698-7255	0		RESISTOR 6.19K 1% .05W F TC=0+100	24546	C3-1/8-T0-6191-F
A4R8	2100-1738	9		RESISTOR-TRMR 10K 10% C TOP-ADJ 1-TRN	73138	82PR10K
A4R9	0757-0446	3		RESISTOR 15K 1% .125W F TC=0+100	24546	C4-1/8-T0-1502-F
A4R10	0757-0446	3		RESISTOR 15K 1% .125W F TC=0+100	24546	C4-1/8-T0-1502-F
A4R11	2100-1984	7	2	RESISTOR-TRMR 100 10% C TOP-ADJ 1-TRN	73138	82PR100
A4R12	2100-1984	7		RESISTOR-TRMR 100 10% C TOP-ADJ 1-TRN	73138	82PR100
A4U1 - U2	1826-0521	3	2	IC OP AMP LOW-BIAS-H-IMPD DUAL 8-DIP-P	01295	TL072CP
	0380-0059	5	1	SPACER, CAPTIVE	28480	0380-0059
A5	05370-60005	4	1	BOARD ASSEMBLY- HP-IB INPUT CONNECTOR (SERIES 1748)	28480	05370-60005
A5H1	2190-0017	4	2	WASHER-LK HLCL NO. 8 .168-IN-ID	28480	2190-0017
A5H2	2190-0017	4		WASHER-LK HLCL NO. 8 .168-IN-ID	28480	2190-0017
A5J3	1252-0324	7	1	CONN-RECT MICRORBN 24-CKT 24-CONT	28480	1252-0324
A5M3	1530-1098	4	2	CLEVIS 0.070-IN W SLT: 0.454-IN PIN CTR	00000	ORDER BY DESCRIPTION
A5M4	1530-1098	4		CLEVIS 0.070-IN W SLT: 0.454-IN PIN CTR	00000	ORDER BY DESCRIPTION
A5MP1	0380-0643	3	2	STANDOFF-HEX .255-IN-LG 6-32THD	00000	ORDER BY DESCRIPTION
A5MP2	0380-0643	3		STANDOFF-HEX .255-IN-LG 6-32THD	00000	ORDER BY DESCRIPTION
A5S1	3101-1973	7	1	SWITCH-SL 7-1A DIP-SLIDE-ASSY .1A 50VDC	28480	3101-1973
A5XJ1	1200-0482	9	2	SOCKET-IC 16-CONT DIP-SLDR	28480	1200-0482
A5XJ2	1200-0482	9		SOCKET-IC 16-CONT DIP-SLDR	28480	1200-0482
A5XS1	1200-0485	2	1	SOCKET-IC 14-CONT DIP DIP-SLDR	28480	1200-0485
	1251-3283	1	1	CONNECTOR, HP-IB F 24-COND MICRORIBBON	28480	1251-3283

See introduction to this section for ordering information
*Indicates factory selected value

Table 6-3. Replaceable Parts (Continued)

Reference Designation	HP Part Number	C D	Qty	Description	Mfr Code	Mfr Part Number
A6	05370-60081	6	1	BOARD ASSEMBLY- POWER SUPPLY CONTROL (SERIES 2716)	28480	05370-60081
A6C1	0180-0491	5	4	CAPACITOR-FXD 10UF+20% 25VDC TA	28480	0180-0491
A6C2	0180-0491	5		CAPACITOR-FXD 10UF+20% 25VDC TA	28480	0180-0491
A6C3	0180-0491	5		CAPACITOR-FXD 10UF+20% 25VDC TA	28480	0180-0491
A6C4	0180-0491	5		CAPACITOR-FXD 10UF+20% 25VDC TA	28480	0180-0491
A6C5	0160-2208	4	4	CAPACITOR-FXD 330PF +5% 300VDC MICA	28480	0160-2208
A6C6	0160-2208	4		CAPACITOR-FXD 330PF +5% 300VDC MICA	28480	0160-2208
A6C7	0160-2208	4		CAPACITOR-FXD 330PF +5% 300VDC MICA	28480	0160-2208
A6C8	0160-2208	4		CAPACITOR-FXD 330PF +5% 300VDC MICA	28480	0160-2208
A6CR1	1902-0522	6	2	DIODE-ZNR 1N5340B 6V 5% PD=5W IR=1UA	04713	1N5340B
A6CR2	1902-0522	6		DIODE-ZNR 1N5340B 6V 5% PD=5W IR=1UA	04713	1N5340B
A6CR3	1902-0632	9	2	DIODE-ZNR 1N5354B 17V 5% PD=5W TC=+75%	04713	1N5354B
A6CR4	1902-0632	9		DIODE-ZNR 1N5354B 17V 5% PD=5W TC=+75%	04713	1N5354B
A6CR5	1902-0074	3	2	DIODE-ZNR 7.15V 5% DO-35 PD=.4W	28480	1902-0074
A6CR6	1902-0074	3		DIODE-ZNR 7.15V 5% DO-35 PD=.4W	28480	1902-0074
A6CR7	1902-0783	1	2	DIODE-ZNR 16V 5% PD=1W IR=5UA	28480	1902-0783
A6CR8	1902-0783	1		DIODE-ZNR 16V 5% PD=1W IR=5UA	28480	1902-0783
A6DS1 - DS4	1990-0620	0	4	LED-LAMP LUM-INT=1MCD IF=20MA-MAX BVR=5V	28480	5082-4584
A6F1	2110-0423	8	2	FUSE 1.5A 125V NTD .281X.093	28480	2110-0423
A6F2	2110-0454	5	2	FUSE 7A 125V .281X.093	28480	2110-0454
A6F3	2110-0454	5		FUSE 7A 125V .281X.093	28480	2110-0454
A6F4	2110-0423	8		FUSE 1.5A 125V NTD .281X.093	28480	2110-0423
A6Q1	1853-0036	2	2	TRANSISTOR PNP SI PD=310MW FT=250MHZ	28480	1853-0036
A6Q2	1854-0215	1	2	TRANSISTOR NPN SI PD=350MW FT=300MHZ	04713	2N3904
A6Q3	1854-0215	1		TRANSISTOR NPN SI PD=350MW FT=300MHZ	04713	2N3904
A6Q4	1853-0036	2		TRANSISTOR PNP SI PD=310MW FT=250MHZ	28480	1853-0036
A6Q5	1853-0020	4	1	TRANSISTOR PNP SI PD=300MW FT=150MHZ	28480	1853-0020
A6Q6	1854-0087	5	1	TRANSISTOR NPN SI PD=360MW FT=75MHZ	28480	1854-0087
A6R1	0811-3499	8	2	RESISTOR .07 3% 5W PW TC=0+90	28480	0811-3499
A6R2	0811-3499	8		RESISTOR .07 3% 5W PW TC=0+90	28480	0811-3499
A6R3	0811-3475	0	2	RESISTOR .4 1% 3W PW TC=0+90	28480	0811-3475
A6R4	0811-3475	0		RESISTOR .4 1% 3W PW TC=0+90	28480	0811-3475
A6R5	0757-0280	3	6	RESISTOR 1K 1% .125W F TC=0+100	24546	C4-1/8-T0-1001-F
A6R6	0757-0280	3		RESISTOR 1K 1% .125W F TC=0+100	24546	C4-1/8-T0-1001-F
A6R7	0698-3444	1	2	RESISTOR 316 1% .125W F TC=0+100	24546	C4-1/8-T0-316R-F
A6R8	0698-3444	1		RESISTOR 316 1% .125W F TC=0+100	24546	C4-1/8-T0-316R-F
A6R9	0698-3258	5	1	RESISTOR 5.36K 1% .125W F TC=0+100	24546	C4-1/8-T0-5361-F
A6R10	0757-0442	9	2	RESISTOR 10K 1% .125W F TC=0+100	24546	C4-1/8-T0-1002-F
A6R11	0757-0280	3		RESISTOR 1K 1% .125W F TC=0+100	24546	C4-1/8-T0-1001-F
A6R12	0698-3279	0	1	RESISTOR 4.99K 1% .125W F TC=0+100	24546	C4-1/8-T0-4991-F
A6R13	0757-0280	3		RESISTOR 1K 1% .125W F TC=0+100	24546	C4-1/8-T0-1001-F
A6R14	0757-0438	3	1	RESISTOR 5.11K 1% .125W F TC=0+100	24546	C4-1/8-T0-5111-F
A6R15	0757-0283	6	4	RESISTOR 2K 1% .125W F TC=0+100	24546	C4-1/8-T0-2001-F
A6R16	0757-0442	9		RESISTOR 10K 1% .125W F TC=0+100	24546	C4-1/8-T0-1002-F
A6R17	0757-0280	3		RESISTOR 1K 1% .125W F TC=0+100	24546	C4-1/8-T0-1001-F
A6R18	0757-0238	6		RESISTOR 2K 1% .125W F TC=0+100	24546	C4-1/8-T0-2001-F
A6R19	0757-0283	6		RESISTOR 2K 1% .125W F TC=0+100	24546	C4-1/8-T0-2001-F
A6R20	0757-0446	3	1	RESISTOR 15K 1% .125W F TC=0+100	24546	C4-1/8-T0-1502-F
A6R21	0757-0238	6		RESISTOR 2K 1% .125W F TC=0+100	24546	C4-1/8-T0-2001-F
A6R22	0757-0280	3		RESISTOR 1K 1% .125W F TC=0+100	24546	C4-1/8-T0-1001-F
A6R23	0811-1037	6	2	RESISTOR 315 1% 3W PW TC=0+20	28480	0811-1037
A6R24	0811-1037	6		RESISTOR 315 1% 3W PW TC=0+20	28480	0811-1037
A6TP1 - TP6	0360-1682	0	6	TERMINAL-STUD SGL-TUR PRESS-MTG	28480	0360-1682
A6U1 - U4	1820-0477	6	4	IC OP AMP GP 8-DIP-P PKG	S0545	UPC301AC
A6U5	1826-0316	4	1	V REF TO-5	27014	LH0070-1H
				A6 MISCELLANEOUS		
	5000-9043	6	1	PIN EXTRACTOR	28480	5000-9043
	5040-6843	2	1	EXTRACTOR BLK	28480	5040-6843

See introduction to this section for ordering information
*Indicates factory selected value

Table 6-2. Replaceable Parts (Continued)

Reference Designation	HP Part Number	C D	Qty	Description	Mfr Code	Mfr Part Number
A7	05370-60007	6	1	BOARD ASSY- OSCILLATOR POWER SUPPLY (SERIES 2648)	28480	05370-60007
A7C1	0160-0128	3	1	CAPACITOR-FXD 2.2UF +20% 50VDC CER	28480	0160-0128
A7C2	0180-2730	9	1	CAPACITOR-FXD 1700UF+75-10% 30VDC AL	28480	0180-2730
A7C3	0160-0576	5	2	CAPACITOR-FXD .1UF +20% 50VDC CER	28480	0160-0576
A7C4	0160-0576	5		CAPACITOR-FXD .1UF +20% 50VDC CER	28480	0160-0576
A7C5	0180-4133	0	1	CAPACITOR-FXD 15UF+10% 20VDC TA	56289	150D156X9020B2
A7CR1	1906-0069	4	1	DIODE-FW BRDG 400V 1A	28480	1906-0069
A7CR2	1901-0028	5	1	DIODE-PWR RECT 400V 750MA DO-29	28480	1901-0028
A7CR3	1902-3172	8	1	DIODE-ZNR 11V 2% DO-35 PD=.4W TC=+.062%	28480	1902-3172
A7F1	2110-0423	8	1	FUSE 1.5A 125V NTD .281X.093	28480	2110-0423
A7Q1	1854-0071	7	1	TRANSISTOR NPN SI PD=300MW FT=200MHZ	28480	1854-0071
A7R1	0757-0420	3	1	RESISTOR 750 1% .125W F TC=0+100	24546	C4-1/8-T0-751-F
A7R2	0757-0726	2	1	RESISTOR 511 1% .25W F TC=0+100	24546	C5-1/4-T0-511R-F
A7TP1 - TP4	0360-1682	0	4	TERMINAL-STUD SGL-TUR PRESS-MTG	28480	0360-1682
A7U1	1826-0147	9	1	IC 7812 V RGLTR TO-220	04713	MC7812CP
				A7 MISCELLANEOUS		
	5000-9043	6	1	PIN EXTRACTOR	28480	5000-9043
	5040-6843	2	1	EXTRACTOR BLK	28480	5040-6843

See introduction to this section for ordering information
*Indicates factory selected value

Table 6-2. Replaceable Parts (Continued)

Reference Designation	HP Part Number	C D	Qty	Description	Mfr Code	Mfr Part Number
A8	05370-60008	7	1	BOARD ASSY- FREQUENCY BUFFER (SERIES 2311)	28480	05370-60008
A8C1	0160-2055	9	1	CAPACITOR-FXD .01UF +80-20% 100VDC CER	28480	0160-2055
A8C2	0160-3877	5	1	CAPACITOR-FXD 100PF +20% 200VDC CER	28480	0160-3877
A8C3 - C6	0160-3879	7	11	CAPACITOR-FXD .01UF +20% 100VDC CER	28480	0160-3879
A8C7 - C8	0140-0234	0	2	CAPACITOR-FXD 500PF +1% 300VDC MICA	72136	DM15F501F0300WV1C
A8C9 - C10	0160-3879	7		CAPACITOR-FXD .01UF +20% 100VDC CER	28480	0160-3879
A8C11	0160-2236	8	1	CAPACITOR-FXD 1PF +- .25PF 500VDC CER	28480	0160-2236
A8C12	0160-4040	6	1	CAPACITOR-FXD 1000PF +20% 100VDC CER	28480	0160-4040
A8C13 - C14	0160-3879	7		CAPACITOR-FXD .01UF +20% 100VDC CER	28480	0160-3879
A8C15	0160-3046	0	3	CAPACITOR-FXD 250PF +1% 100VDC MICA	28480	0160-3046
A8C16	0180-0491	5	3	CAPACITOR-FXD 10UF+20% 25VDC TA	28480	0180-0491
A8C17	0180-0491	5		CAPACITOR-FXD 10UF+20% 25VDC TA	28480	0180-0491
A8C18	0160-3879	7		CAPACITOR-FXD .01UF +20% 100VDC CER	28480	0160-3879
A8C19	0160-2240	4	1	CAPACITOR-FXD 2PF +- .25PF 500VDC CER	28480	0160-2240
A8C20	0160-2197	0	2	CAPACITOR-FXD 10PF +5% 300VDC MICA	28480	0160-2197
A8C21 - C22	0160-3046	0		CAPACITOR-FXD 250PF +1% 100VDC MICA	28480	0160-3046
A8C23	0160-3879	7		CAPACITOR-FXD .01UF +20% 100VDC CER	28480	0160-3879
A8C24	0180-0491	5		CAPACITOR-FXD 10UF+20% 25VDC TA	28480	0180-0491
A8C25	0160-3879	7		CAPACITOR-FXD .01UF +20% 100VDC CER	28480	0160-3879
A8C26	0160-2197	0		CAPACITOR-FXD 10PF +5% 300VDC MICA	28480	0160-2197
A8CR1	1901-0535	9	1	DIODE-SM SIG SCHOTTKY	28480	1901-0535
A8CR2	1901-0040	1	1	DIODE-SWITCHING 30V 50MA 2NS DO-35	28480	1901-0040
A8DS1	1990-0620	0	1	LED-LAMP,YELLOW	28480	5082-4584
A8L1 - L4	9100-0348	2	4	INDUCTOR RF-CH-MLD 1UH 1% .166DX.385LG	28480	9100-0348
A8L5 - L6	9100-1788	6	2	CORE-FERRITE CHOKE-WIDEBAND; IMP:>680	28480	9100-1788
A8Q1	1854-0215	1	6	TRANSISTOR NPN SI PD=350MW FT=300MHZ	04713	2N3904
A8Q2	1854-0215	1		TRANSISTOR NPN SI PD=350MW FT=300MHZ	04713	2N3904
A8Q3	1854-0809	1	1	TRANSISTOR NPN SI PD=300MW FT=600MHZ	04713	2N2369A
A8Q4	1854-0215	1		TRANSISTOR NPN SI PD=350MW FT=300MHZ	04713	2N3904
A8Q5	1854-0215	1		TRANSISTOR NPN SI PD=350MW FT=300MHZ	04713	2N3904
A8Q6	1853-0036	2	2	TRANSISTOR PNP SI PD=310MW FT=250MHZ	28480	1853-0036
A8Q7	1854-0215	1		TRANSISTOR NPN SI PD=350MW FT=300MHZ	04713	2N3904
A8Q8	1853-0036	2		TRANSISTOR PNP SI PD=310MW FT=250MHZ	28480	1853-0036
A8Q9	1854-0215	1		TRANSISTOR NPN SI PD=350MW FT=300MHZ	04713	2N3904
A8R1	1810-0080	6	5	NETWORK-RES 8-SIP500.0 OHM X 7	28480	1810-0080
A8R2	0757-0413	4	1	RESISTOR 392 1% .125W F TC=0+100	24546	C4-1/8-T0-392R-F
A8R3	1810-0080	6		NETWORK-RES 8-SIP500.0 OHM X 7	28480	1810-0080
A8R4	0757-1093	8	1	RESISTOR 3K 1% .125W F TC=0+100	24546	C4-1/8-T0-3001-F
A8R5	0698-3443	0	1	RESISTOR 287 1% .125W F TC=0+100	24546	C4-1/8-T0-287R-F
A8R6	0757-0280	3	6	RESISTOR 1K 1% .125W F TC=0+100	24546	C4-1/8-T0-1001-F
A8R7	1810-0080	6		NETWORK-RES 8-SIP500.0 OHM X 7	28480	1810-0080
A8R8	0698-3437	2	1	RESISTOR 133 1% .125W F TC=0+100	24546	C4-1/8-T0-133R-F
A8R9	0757-0394	0	1	RESISTOR 51.1 1% .125W F TC=0+100	24546	C4-1/8-T0-51R1-F
A8R10	1810-0080	6		NETWORK-RES 8-SIP500.0 OHM X 7	28480	1810-0080
A8R11 - R12	0757-0442	9	4	RESISTOR 10K 1% .125W F TC=0+100	24546	C4-1/8-T0-1002-F
A8R13	0757-0280	3		RESISTOR 1K 1% .125W F TC=0+100	24546	C4-1/8-T0-1001-F
A8R14	0757-0442	9		RESISTOR 10K 1% .125W F TC=0+100	24546	C4-1/8-T0-1002-F
A8R15	0757-0280	3		RESISTOR 1K 1% .125W F TC=0+100	24546	C4-1/8-T0-1001-F
A8R16	0757-0346	2	1	RESISTOR 10 1% .125W F TC=0+100	24546	C4-1/8-T0-10R0-F
A8R17 - R18	0757-0280	3		RESISTOR 1K 1% .125W F TC=0+100	24546	C4-1/8-T0-1001-F
A8R19	0757-0442	9		RESISTOR 10K 1% .125W F TC=0+100	24546	C4-1/8-T0-1002-F
A8R20 - R21	0757-0280	3		RESISTOR 1K 1% .125W F TC=0+100	24546	C4-1/8-T0-1001-F
A8R22	1810-0080	6		NETWORK-RES 8-SIP500.0 OHM X 7	28480	1810-0080
A8TP1 - TP4	0360-1682	0	4	TERMINAL-STUD SGL-TUR PRESS-MTG	28480	0360-1682
A8U1, U2, U4	1820-0803	2	3	IC GATE ECL OR-NOR TPL	04713	MC10105P
A8U3	1820-0802	1	1	IC GATE QUAD 2-INP NOR	04713	MC10102P
A8U5 - U6	1820-1224	3	2	IC RCVR ECL LINE RCVR TPL 2-INP	04713	MC10216P
				A8 MISCELLANEOUS		
	5000-9043	6	1	PIN EXTRACTOR	28480	5000-9043
	5040-6843	2	1	EXTRACTOR BLK	28480	5040-6843

See introduction to this section for ordering information
*Indicates factory selected value

Table 6-2. Replaceable Parts (Continued)

Reference Designation	HP Part Number	C D	Qty	Description	Mfr Code	Mfr Part Number
A9	05370-60082		1	BOARD ASSEMBLY- PROCESSOR (SERIES 2808)	28480	05370-60082
A9C1 - C10	0160-3879	7	15	CAPACITOR-FXD .01UF +20% 100VDC CER	28480	0160-3879
A9C11	0180-0106	9	2	CAPACITOR-FXD 60UF+20% 6VDC TA	56289	150D606X0006B2
A9C12	0160-3651	3	2	CAPACITOR-FXD 68PF +10% 200VDC CER	28480	0160-3651
A9C13	0160-3879	7		CAPACITOR-FXD .01UF +20% 100VDC CER	28480	0160-3879
A9C14	0160-3879	7		CAPACITOR-FXD .01UF +20% 100VDC CER	28480	0160-3879
A9C15	0160-2743	2	2	CAPACITOR-FXD 33PF +10% 200VDC CER	28480	0160-2743
A9C16	0160-3879	7		CAPACITOR-FXD .01UF +20% 100VDC CER	28480	0160-3879
A9C17	0160-3651	3		CAPACITOR-FXD 68PF +10% 200VDC CER	28480	0160-3651
A9C18	0160-3879	7		CAPACITOR-FXD .01UF +20% 100VDC CER	28480	0160-3879
A9C19	0160-2743	2		CAPACITOR-FXD 33PF +10% 200VDC CER	28480	0160-2743
A9C20	0180-0106	9		CAPACITOR-FXD 60UF+20% 6VDC TA	56289	150D606X0006B2
A9C21	0160-3879	7		CAPACITOR-FXD .01UF +20% 100VDC CER	28480	0160-3879
A9CR1	1901-0040	1	1	DIODE-SWITCHING 30V 50MA 2NS DO-35	28480	1901-0040
A9L1	9100-1788	6	1	CORE-FERRITE CHOKE-WIDEBAND; IMP:>680	28480	9100-1788
A9MP1 - MP2	0403-0189	2	2	EXTR-PC BD BLK POLYC .062-BD-THKNS	28480	0403-0189
A9MP3 - MP4	1480-0116	8	2	PIN-GRV .062-IN-DIA .25-IN-LG STL	28480	1480-0116
A9Q1	1854-0560	9	1	TRANSISTOR NPN SI DARL PD=310MW	04713	MPS A12
A9R1 - R3	1810-0279	5	3	NETWORK-RES 10-SIP 4.7K OHM X 9	01121	210A472
A9R4	0698-7205	0	1	RESISTOR 51.1 1% .05W F TC=0+100	24546	C3-1/8-T0-51R1-F
A9R5	0698-7252	7	4	RESISTOR 4.64K 1% .05W F TC=0+100	24546	C3-1/8-T0-4641-F
A9R6	1810-0277	3	1	NETWORK-RES 10-SIP2.2K OHM X 9	01121	210A222
A9R7	0698-7246	9	1	RESISTOR 2.61K 1% .05W F TC=0+100	24546	C3-1/8-T0-2611-F
A9R8	0757-0405	4	1	RESISTOR 162 1% .125W F TC=0+100	24546	C4-1/8-T0-162R-F
A9R9	0698-7268	5	1	RESISTOR 21.5K 1% .05W F TC=0+100	24546	C3-1/8-T0-2152-F
A9R10	0698-7236	7	8	RESISTOR 1K 1% .05W F TC=0+100	24546	C3-1/8-T0-1001-F
A9R11	0698-7236	7		RESISTOR 1K 1% .05W F TC=0+100	24546	C3-1/8-T0-1001-F
A9R12	0698-7248	1	2	RESISTOR 3.16K 1% .05W F TC=0+100	24546	C3-1/8-T0-3161-F
A9R13	0698-7248	1		RESISTOR 3.16K 1% .05W F TC=0+100	24546	C3-1/8-T0-3161-F
A9R14	0757-0465	6	1	RESISTOR 100K 1% .125W F TC=0+100	24546	C4-1/8-T0-1003-F
A9R15	0698-7252	7		RESISTOR 4.64K 1% .05W F TC=0+100	24546	C3-1/8-T0-4641-F
A9R16	0698-7260	7	3	RESISTOR 10K 1% .05W F TC=0+100	24546	C3-1/8-T0-1002-F
A9R17	0698-7236	7		RESISTOR 1K 1% .05W F TC=0+100	24546	C3-1/8-T0-1001-F
A9R18	0698-7260	7		RESISTOR 10K 1% .05W F TC=0+100	24546	C3-1/8-T0-1002-F
A9R19	0698-7236	7		RESISTOR 1K 1% .05W F TC=0+100	24546	C3-1/8-T0-1001-F
A9R20	0698-7252	7		RESISTOR 4.64K 1% .05W F TC=0+100	24546	C3-1/8-T0-4641-F
A9R21	0698-7188	8	2	RESISTOR 10 1% .05W F TC=0+100	24546	C3-1/8-T0-10R-F
A9R22	0698-7196	8	2	RESISTOR 21.5 1% .05W F TC=0+100	24546	C3-1/8-T0-21R5-F
A9R23	0698-7236	7		RESISTOR 1K 1% .05W F TC=0+100	24546	C3-1/8-T0-1001-F
A9R24	0698-7196	8		RESISTOR 21.5 1% .05W F TC=0+100	24546	C3-1/8-T0-21R5-F
A9R25	0698-7236	7		RESISTOR 1K 1% .05W F TC=0+100	24546	C3-1/8-T0-1001-F
A9R26	0698-7188	8		RESISTOR 10 1% .05W F TC=0+100	24546	C3-1/8-T0-10R-F
A9R27	0698-7252	7		RESISTOR 4.64K 1% .05W F TC=0+100	24546	C3-1/8-T0-4641-F
A9R28	0698-7236	7		RESISTOR 1K 1% .05W F TC=0+100	24546	C3-1/8-T0-1001-F
A9R29	0698-7236	7		RESISTOR 1K 1% .05W F TC=0+100	24546	C3-1/8-T0-1001-F
A9R30	0698-7260	7		RESISTOR 10K 1% .05W F TC=0+100	24546	C3-1/8-T0-1002-F
A9S1	3101-1989	5	1	SWITCH-SL 10-1A DIP-SLIDE-ASSY .1A 50VDC	28480	3101-1989
A9TP1 - TP4	0360-1682	0	4	TERMINAL-STUD SGL-TUR PRESS-MTG	28480	0360-1682
A9U1	1820-1081	0	2	IC DRVR TTL S BUS QUAD	18324	8T26AN
A9U2	1820-1081	0		IC DRVR TTL S BUS QUAD	18324	8T26AN
A9U3	05370-80009		1	ROM, PROGRAMMED	28480	05370-80009
A9U4	1820-1202	7	1	IC GATE TTL LS NAND TPL 3-INP	01295	SN74LS10N
A9U5	1818-0135	8	3	IC NMOS 1024 (1K) STAT RAM 360-NS 3-S	04713	MCM68A10L
A9U6	1820-1199	1	2	IC INV TTL LS HEX 1-INP	01295	SN74LS04N
A9U7	1820-1197	9	2	IC GATE TTL LS NAND QUAD 2-INP	01295	SN74LS00N
A9U8	1818-0135	8		IC NMOS 1024 (1K) STAT RAM 360-NS 3-S	04713	MCM68A10L
A9U9	1820-1204	9	1	IC GATE TTL LS NAND DUAL 4-INP	01295	SN74LS20N
A9U10	1818-0135	8		IC NMOS 1024 (1K) STAT RAM 360-NS 3-S	04713	MCM68A10L

See introduction to this section for ordering information
*Indicates factory selected value

Table 6-2. Replaceable Parts (Continued)

Reference Designation	HP Part Number	C D	Qty	Description	Mfr Code	Mfr Part Number
A9U11	1820-1196	8	1	IC FF TTL LS D-TYPE POS-EDGE-TRIG COM	01295	SN74LS174N
A9U12	1820-1640		3	IC DRVR TTL BUS HEX 1-INP	27014	DM8096N
A9U13	05370-80003	4	1	ROM-PROGRAMMED	28480	05370-80003
A9U14	1820-1640			IC DRVR TTL BUS HEX 1-INP	27014	DM8096N
A9U15	1820-1209	4	1	IC BFR TTL LS NAND QUAD 2-INP	01295	SN74LS38N
A9U16	1820-1640			IC DRVR TTL BUS HEX 1-INP	27014	DM8096N
A9U17	1820-1199	1		IC INV TTL LS HEX 1-INP	01295	SN74LS04N
A9U18	1820-2137	9	1	IC MICPROC NMOS 8-BIT	04713	MC68A00P
A9U19	1820-1804	5	1	IC BFR NMOS CLOCK DRVR	04713	MPQ6842
A9U20	1820-1197	9		IC GATE TTL LS NAND QUAD 2-INP	01295	SN74LS00N
A9XU3	1200-0567		1	SOCKET-IC 28-CONT	28480	1200-0565
A10				NOT ASSIGNED		

See introduction to this section for ordering information
 *Indicates factory selected value

Table 6-2. Replaceable Parts (Continued)

Reference Designation	HP Part Number	C D	Qty	Description	Mfr Code	Mfr Part Number
A11	05370-60011	2	1	BOARD ASSEMBLY- DISPLAY INTERFACE (SERIES 1808)	28480	05370-60011
A11C1	0160-4040	6	6	CAPACITOR-FXD 1000PF +20% 100VDC CER	28480	0160-4040
A11C2	0160-3879	7		CAPACITOR-FXD .01UF +20% 100VDC CER	28480	0160-3879
A11C3 - C7	0160-4040	6	6	CAPACITOR-FXD 1000PF +20% 100VDC CER	28480	0160-4040
A11C8 - C15	0160-3879	7		CAPACITOR-FXD .01UF +20% 100VDC CER	28480	0160-3879
A11C16	0180-0230	0	2	CAPACITOR-FXD 1UF+20% 50VDC TA	56289	150D105X0050A2
A11C17	0180-0106	9	1	CAPACITOR-FXD 60UF+20% 6VDC TA	56289	150D606X0006B2
A11C18	0160-3879	7		CAPACITOR-FXD .01UF +20% 100VDC CER	28480	0160-3879
A11C19	0180-0230	0		CAPACITOR-FXD 1UF+20% 50VDC TA	56289	150D105X0050A2
A11C20	0180-1714	7	1	CAPACITOR-FXD 330UF+10% 6VDC TA	56289	150D337X9006S2
A11J1- J3	1200-0482	9	3	SOCKET-IC 16-CONT DIP-SLDR	28480	1200-0482
A11L1	9100-1788	6	2	CORE-FERRITE CHOKE-WIDEBAND; IMP:>680	28480	9100-1788
A11L2	9100-3060	1	1	INDUCTOR 280UH 15%	28480	9100-3060
A11L3	9100-1788	6		CORE-FERRITE CHOKE-WIDEBAND; IMP:>680	28480	9100-1788
A11MP1	0403-0189	2	2	EXTR-PC BD BLK POLYC .062-BD-THKNS	28480	0403-0189
A11MP2	0403-0189	2		EXTR-PC BD BLK POLYC .062-BD-THKNS	28480	0403-0189
A11MP3	1400-0249	0	1	CABLE TIE .062-.625-DIA .091-WD NYL	28480	1400-0249
A11MP4 - MP5	1480-0116	8	2	PIN-GRV .062-IN-DIA .25-IN-LG STL	28480	1480-0116
A11Q1 - Q16	1853-0326	3	16	TRANSISTOR PNP SI PD=1W FT=50MHZ	04713	MPS-U51
A11R1	0698-3435	0	12	RESISTOR 38.3 1% .125W F TC=0+100	24546	C4-1/8-T0-38R3-F
A11R2	0698-3435	0		RESISTOR 38.3 1% .125W F TC=0+100	24546	C4-1/8-T0-38R3-F
A11R3	0698-7205	0	7	RESISTOR 51.1 1% .05W F TC=0+100	24546	C3-1/8-T0-51R1-F
A11R4	0698-3435	0		RESISTOR 38.3 1% .125W F TC=0+100	24546	C4-1/8-T0-38R3-F
A11R5	0698-3435	0		RESISTOR 38.3 1% .125W F TC=0+100	24546	C4-1/8-T0-38R3-F
A11R6	0698-7205	0		RESISTOR 51.1 1% .05W F TC=0+100	24546	C3-1/8-T0-51R1-F
A11R7	1810-0141	0	2	NETWORK-RES 9-SIP330.0 OHM X 8	91637	CSP09C07-331J
A11R8	0698-7218	5	16	RESISTOR 178 1% .05W F TC=0+100	24546	C3-1/8-T0-178R-F
A11R9	0698-3435	0		RESISTOR 38.3 1% .125W F TC=0+100	24546	C4-1/8-T0-38R3-F
A11R10	0698-3435	0		RESISTOR 38.3 1% .125W F TC=0+100	24546	C4-1/8-T0-38R3-F
A11R11	0698-7205	0		RESISTOR 51.1 1% .05W F TC=0+100	24546	C3-1/8-T0-51R1-F
A11R12	0698-7218	5		RESISTOR 178 1% .05W F TC=0+100	24546	C3-1/8-T0-178R-F
A11R13	0698-3435	0		RESISTOR 38.3 1% .125W F TC=0+100	24546	C4-1/8-T0-38R3-F
A11R14	0698-3435	0		RESISTOR 38.3 1% .125W F TC=0+100	24546	C4-1/8-T0-38R3-F
A11R15	0698-7205	0		RESISTOR 51.1 1% .05W F TC=0+100	24546	C3-1/8-T0-51R1-F
A11R16	0698-7218	5		RESISTOR 178 1% .05W F TC=0+100	24546	C3-1/8-T0-178R-F
A11R17	0698-3435	0		RESISTOR 38.3 1% .125W F TC=0+100	24546	C4-1/8-T0-38R3-F
A11R18	0698-3435	0		RESISTOR 38.3 1% .125W F TC=0+100	24546	C4-1/8-T0-38R3-F
A11R19	0698-7205	0		RESISTOR 51.1 1% .05W F TC=0+100	24546	C3-1/8-T0-51R1-F
A11R20	0698-7218	5		RESISTOR 178 1% .05W F TC=0+100	24546	C3-1/8-T0-178R-F
A11R21	0698-3435	0		RESISTOR 38.3 1% .125W F TC=0+100	24546	C4-1/8-T0-38R3-F
A11R22	0698-3435	0		RESISTOR 38.3 1% .125W F TC=0+100	24546	C4-1/8-T0-38R3-F
A11R23	0698-7205	0		RESISTOR 51.1 1% .05W F TC=0+100	24546	C3-1/8-T0-51R1-F
A11R24	0698-7218	5		RESISTOR 178 1% .05W F TC=0+100	24546	C3-1/8-T0-178R-F
A11R25	0698-7205	0		RESISTOR 51.1 1% .05W F TC=0+100	24546	C3-1/8-T0-51R1-F
A11R26	0698-7218	5		RESISTOR 178 1% .05W F TC=0+100	24546	C3-1/8-T0-178R-F
A11R27	0698-7218	5		RESISTOR 178 1% .05W F TC=0+100	24546	C3-1/8-T0-178R-F
A11R28	0698-7218	5		RESISTOR 178 1% .05W F TC=0+100	24546	C3-1/8-T0-178R-F
A11R29	1810-0141	0		NETWORK-RES 9-SIP330.0 OHM X 8	91637	CSP09C07-331J
A11R30	0698-7218	5		RESISTOR 178 1% .05W F TC=0+100	24546	C3-1/8-T0-178R-F
A11R31	0698-7218	5		RESISTOR 178 1% .05W F TC=0+100	24546	C3-1/8-T0-178R-F
A11R32	0698-7218	5		RESISTOR 178 1% .05W F TC=0+100	24546	C3-1/8-T0-178R-F
A11R33	0698-7218	5		RESISTOR 178 1% .05W F TC=0+100	24546	C3-1/8-T0-178R-F
A11R34	0698-7218	5		RESISTOR 178 1% .05W F TC=0+100	24546	C3-1/8-T0-178R-F
A11R35	0698-7218	5		RESISTOR 178 1% .05W F TC=0+100	24546	C3-1/8-T0-178R-F
A11R36	0698-7218	5		RESISTOR 178 1% .05W F TC=0+100	24546	C3-1/8-T0-178R-F
A11R37	0698-7218	5		RESISTOR 178 1% .05W F TC=0+100	24546	C3-1/8-T0-178R-F
A11R38	1810-0176	1	2	NETWORK-RES 5-SIP4.7K OHM X 4	28480	1810-0176
A11R39	1810-0176	1		NETWORK-RES 5-SIP4.7K OHM X 4	28480	1810-0176
A11R40	0757-0416	7	1	RESISTOR 511 1% .125W F TC=0+100	24546	C4-1/8-T0-511R-F

See introduction to this section for ordering information
*Indicates factory selected value

Table 6-2. Replaceable Parts (Continued)

Reference Designation	HP Part Number	C D	Qty	Description	Mfr Code	Mfr Part Number
A11R41	0698-3132	4	1	RESISTOR 261 1% .125W F TC=0+-100	24546	C4-1/8-T0-2610-F
A11R42	0757-0469	0	2	RESISTOR 150K 1% .125W F TC=0+-100	24546	C4-1/8-T0-1503-F
A11R43	0757-0469	0		RESISTOR 150K 1% .125W F TC=0+-100	24546	C4-1/8-T0-1503-F
A11TP1 - TP6	0360-1682	0	6	TERMINAL-STUD SGL-TUR PRESS-MTG	28480	0360-1682
A11U1	1820-0799	5	6	IC DRVR TTL NAND DUAL 2-INP	01295	SN75452BP
A11U2	1816-1089	9	3	IC TTL LS 64-BIT STAT RAM 80-NS 3-S	27014	DM74LS189N
A11U3	1820-0799	5		IC DRVR TTL NAND DUAL 2-INP	01295	SN75452BP
A11U4	1816-1089	9		IC TTL LS 64-BIT STAT RAM 80-NS 3-S	27014	DM74LS189N
A11U5	1820-0468	5	2	IC DCDR TTL BCD-TO-DEC 4-TO-10-LINE	01295	SN7445N
A11U6	1820-0799	5		IC DRVR TTL NAND DUAL 2-INP	01295	SN75452BP
A11U7	1816-1089	9		IC TTL LS 64-BIT STAT RAM 80-NS 3-S	27014	DM74LS189N
A11U8	1820-0799	5		IC DRVR TTL NAND DUAL 2-INP	01295	SN75452BP
A11U9	1820-1885	2	2	IC RGTR TTL LS D-TYPE QUAD	27014	DM74LS173N
A11U10	1820-0799	5		IC DRVR TTL NAND DUAL 2-INP	01295	SN75452BP
A11U11	1820-1428	9	1	IC MUXR/DATA-SEL TTL LS 2-TO-1-LINE QUAD	01295	SN74LS158N
A11U12	1820-0799	5		IC DRVR TTL NAND DUAL 2-INP	01295	SN75452BP
A11U13	1820-1885	2		IC RGTR TTL LS D-TYPE QUAD	27014	DM74LS173N
A11U14	1820-0468	5		IC DCDR TTL BCD-TO-DEC 4-TO-10-LINE	01295	SN7445N
A11U15	1820-1204	9	3	IC GATE TTL LS NAND DUAL 4-INP	01295	SN74LS20N
A11U16	1820-1207	2	1	IC GATE TTL LS NAND 8-INP	01295	SN74LS30N
A11U17	1820-1443	8	1	IC CNTR TTL LS BIN ASYNCHRO	01295	SN74LS293N
A11U18	1820-1204	9		IC GATE TTL LS NAND DUAL 4-INP	01295	SN74LS20N
A11U19	1820-1199	1	2	IC INV TTL LS HEX 1-INP	01295	SN74LS04N
A11U20	1820-1202	7	1	IC GATE TTL LS NAND TPL 3-INP	01295	SN74LS10N
A11U21	1820-1197	9	1	IC GATE TTL LS NAND QUAD 2-INP	01295	SN74LS00N
A11U22	1820-1112	8	1	IC FF TTL LS D-TYPE POS-EDGE-TRIG	01295	SN74LS74AN
A11U23	1820-2096	9	1	IC CNTR TTL LS BIN DUAL 4-BIT	07263	74LS393
A11U24	1820-1199	1		IC INV TTL LS HEX 1-INP	01295	SN74LS04N
A11U25	5080-8624		1	IC GATE TTL NAND QUAD 2-INP	28480	5080-8624
A11U26	1820-1204	9		IC GATE TTL LS NAND DUAL 4-INP	01295	SN74LS20N
A11U27	1820-1423	4	1	IC MV TTL LS MONOSTBL RETRIG DUAL	01295	SN74LS123N
A12				NOT ASSIGNED		
A13				NOT ASSIGNED		

See introduction to this section for ordering information
*Indicates factory selected value

Table 6-2. Replaceable Parts (Continued)

Reference Designation	HP Part Number	C D	Qty	Description	Mfr Code	Mfr Part Number
A14	05370-60014	5	1	BD ASSY, SERVICE AID (SERIES 1748)	28480	05370-60014
A14C1 - C10	0160-3879	7	16	CAPACITOR-FXD .01UF +20% 100VDC CER	28480	0160-3879
A14C11	0180-4133	0	3	CAPACITOR-FXD 15UF +10% 20VDC TA	67289	150D156X9020B2
A14C12	0160-3877	5	2	CAPACITOR-FXD 100PF +20% 200VEC CER	28480	0160-3877
A14C13	0160-3879	7		CAPACITOR-FXD .01UF +20% 100VDC CER	28480	0160-3879
A14C14	0160-3877	5		CAPACITOR-FXD 100PF +20% 200VEC CER	28480	0160-3877
A14C15 - C17	0160-3879	7		CAPACITOR-FXD .01UF +20% 100VDC CER	28480	0160-3879
A14C18	0180-4133	0		CAPACITOR-FXD 15UF +10% 20VDC TA	67289	150D156X9020B2
A14C19	0160-3879	7		CAPACITOR-FXD .01UF +20% 100VDC CER	28480	0160-3879
A14C20	0160-0576	5	2	CAPACITOR-FXD .1UF +20% 50VDC CER	28480	0160-0576
A14C21	0160-3879	7		CAPACITOR-FXD .01UF +20% 100VDC CER	28480	0160-3879
A14C22	0160-0576	5		CAPACITOR-FXD .1UF +20% 50VDC CER	28480	0160-0576
A14C23 - C24	0160-2743	2	2	CAPACITOR-FXD 33PF +10% 200VDC CER	28480	0160-2743
A14C25 - C26	0180-0106	9	2	CAPACITOR-FXD 60UF +20% 6VDC TA	56289	150D606X0006B2
A14C27	0180-4133	0		CAPACITOR-FXD 15UF +10% 20VDC TA	67289	150D156X9020B2
A14CR1	1902-0033	4	1	DIODE-ZNE 1N823 6.2V 5% DO-7 -PD=.4W	24046	1N823
A14J1 - J2	1200-0482	9	2	SOCKET-IC 16-CONT DIP-SLDR	28480	1200-0519
A14L1 - L4	9100-1788	6	4	CORE-FERRITE CHOKE-WIDEBAND; IIMP:>680	28480	9100-1788
A14MP1 - MP2	0403-0189	2	2	EXTR PC BD BLK POLYCY .062-BD-THKNS	28480	0403-0189
A14MP3 MP4	1480-0116	8	2	PIN GRV .062-IN-DIA .25-IN-LG STL	28480	1480-0116
A14R1	0757-0394	0	1	RESISTOR 51.1 1% .125W F TC=0+100	24546	C4-1/8-TO-51R1-F
A14R2 - R3	1810-0176	1	2	NETWORK-RES 5-SIP 4.7K OHM X 4	28480	1810-0176
A14R4 - R6	0757-0279	0	4	RESISTOR 3.16K 1% .125W F TC=0+100	24546	C4-1/8-TO3161-F
A14R7	0698-0085	0	5	RESISTOR 2.61K 1% .125W F TC=0+100	24546	C4-1/8-TO-2611-F
A14R8	0757-0279	0		RESISTOR 3.16K 1% .125W F TC=0+100	24546	C4-1/8-TO3161-F
A14R9	0698-0085	0		RESISTOR 2.61K 1% .125W F TC=0+100	24546	C4-1/8-TO-2611-F
A14R10	0757-0317	7	2	RESISTOR 1.33K 1% .125W F TC=0+100	24546	C4-1/8-TO-1331-F
A14R11	0757-0317	7		RESISTOR 1.33K 1% .125W F TC=0+100	24546	C4-1/8-TO-1331-F
A14R12	0757-0424	7	2	RESISTOR 1.1K 1% .125W F TC=0+100	24546	C4-1/8-TO-1101-F
A14R13	0757-0424	7		RESISTOR 1.1K 1% .125W F TC=0+100	24546	C4-1/8-TO-1101-F
A14R14 - R16	0698-0085	0		RESISTOR 2.61K 1% .125W F TC=0+100	24546	C4-1/8-TO-2611-F
A14R17 - R18				NOT ASSIGNED		
A14R19 - R20	0698-0082	7	2	RESISTOR 484 1% .125W F TC=0+100	24546	C4-1/8-TO-4640-F
A143S1 - S3	3101-1277	4	3	SWITCH TGL SUBMIN SPDT .5A 120VAC PC	28480	3101-1277
A14TP1 - TP8	0360-1682	0	8	TERMINAL STUD SGL TUR PRESS-MTD	28480	0360-1682
A14U1 - U2	1820-1419	8	4	IC COMPTR TTL LS MAGTD 4-BIT	01295	SN74LS85N
A14U3	1820-1216	3	1	IC DCDR TTL LS 3-TO-8-LINE 3-INP	01295	SN74LS138N
A14U4 - U5	1820-1195	7	5	IC FF TTL LS D-TYPE POS-EDGE-TRIG COM	01295	SN74LS175N
A14U6	1820-1207	2	1	IC GATE TTL LS NAND 8-INP	01295	SN74LS30N
A14U7 - U8	1820-1419	8		IC COMPTR TTL LS MAGTD 4-BIT	01295	SN74LS85N
A14U9	1820-1204	9	1	IC GATE TTL LS NAND DUAL 4-INP	01295	SN74LS20N
A14U10 - U12	1820-1195	7		IC FF TTL LS D-TYPE POS-EDGE-TRIG COM	01295	SN74LS175N
A14U13	1820-1197	9	3	IC GATE TTL LS NAND QUAD 2-INP	01295	SN74LS00N
A14U14	1820-1414	3	1	IC GATE TTL LS NAND TPL 3-INP	01295	SN74LS12N
A14U15 - U16	1820-1197	9		IC GATE TTL LS NAND QUAD 2-INP	01295	SN74LS00N
A14U17	1820-1198	0	1	IC GATE TTL LS NAND QUAD 2-INP	01295	SN74LS03N
A14U18- U19	1826-0188	8	2	IC CONV 8-B-D/A 16-DIP-C PKG	04713	MN1408L-8
A14U20 - U21	1826-0207	2	2	IC OP AMP WB 8-DIP-P PKG	01295	LM318P

See introduction to this section for ordering information
*Indicates factory selected value

Table 6-2. Replaceable Parts (Continued)

Reference Designation	HP Part Number	C D	Qty	Description	Mfr Code	Mfr Part Number
A15	05370-60015	6	1	BOARD ASSEMBLY- HP-IB INTERFACE (SERIES 2732)	28480	05370-60015
A15C1 - C11	0160-3879	7	11	CAPACITOR-FXD .01UF +20% 100VDC CER	28480	0160-3879
A15C12	0180-0106	9	1	CAPACITOR-FXD 60UF+20% 6VDC TA	56289	150D606X0006B2
A15C13	0160-4832	4	1	CAPACITOR-FXD 0.01UF 100V	28480	0160-4832
A15DS1 - DS4	1990-0620	0	4	LED-LAMP LUM-INT=1MCD IF=20MA-MAX BVR=5V	28480	5082-4584
A15J1 - J2	1200-0482	9	2	SOCKET-IC 16-CONT DIP-SLDR	28480	1200-0482
A15L1	9100-1788	6	1	CORE-FERRITE CHOKE-WIDEBAND; IMP:>680	28480	9100-1788
A15MP1 - MP2	0403-0189	2	2	EXTR-PC BD BLK POLYC .062-BD-THKNS	28480	0403-0189
A15MP3 - MP4	1480-0116	8	2	PIN-GRV .062-IN-DIA .25-IN-LG STL	28480	1480-0116
A15R1	0757-0394	0	1	RESISTOR 51.1 1% .125W F TC=0+-100	24546	C4-1/8-T0-51R1-F
A15R2 - R5	0757-0416	7	4	RESISTOR 511 1% .125W F TC=0+-100	24546	C4-1/8-T0-511R-F
A15R6 - R8	1810-0164	7	3	NETWORK-RES 9-SIP4.7K OHM X 8	91637	CSP09C07-472J
A15TP1 - TP2	0360-1682	0	2	TERMINAL-STUD SGL-TUR PRESS-MTG	28480	0360-1682
A15U1	1820-1112	8	8	IC FF TTL LS D-TYPE POS-EDGE-TRIG	01295	SN74LS74AN
A15U2	1820-1216	3	1	IC DCDR TTL LS 3-TO-8-LINE 3-INP	01295	SN74LS138N
A15U3	1820-1112	8	8	IC FF TTL LS D-TYPE POS-EDGE-TRIG	01295	SN74LS74AN
A15U4	1820-1211	8	1	IC GATE TTL LS EXCL-OR QUAD 2-INP	01295	SN74LS86AN
A15U5	1820-3460	3	1	IC GATE TTL LS NAND 8-INP	01295	SN74LS30N
A15U6	1820-1112	8	8	IC FF TTL LS D-TYPE POS-EDGE-TRIG	01295	SN74LS74AN
A15U7	1820-0068	1	1	IC GATE TTL NAND TPL 3-INP	01295	SN7410N
A15U8	1820-1885	2	1	IC RGTR TTL LS D-TYPE QUAD	27014	DM74LS173N
A15U9	1820-1112	8	8	IC FF TTL LS D-TYPE POS-EDGE-TRIG	01295	SN74LS74AN
A15U10	1820-1368	6	2	IC DRVR TTL BUS HEX 1-INP	27014	DM8096N
A15U11	1820-1196	8	1	IC FF TTL LS D-TYPE POS-EDGE-TRIG COM	01295	SN74LS174N
A15U12	1820-1198	0	1	IC GATE TTL LS NAND QUAD 2-INP	01295	SN74LS03N
A15U13	1820-1368	6	6	IC DRVR TTL BUS HEX 1-INP	27014	DM8096N
A15U14	1820-1206	1	1	IC GATE TTL LS NOR TPL 3-INP	01295	SN74LS27N
A15U15	1820-1112	8	8	IC FF TTL LS D-TYPE POS-EDGE-TRIG	01295	SN74LS74AN
A15U16	1820-1282	3	2	IC FF TTL LS J-K BAR POS-EDGE-TRIG	01295	SN74LS109AN
A15U17	1820-1144	6	4	IC GATE TTL LS NOR QUAD 2-INP	01295	SN74LS02N
A15U18	1820-1112	8	8	IC FF TTL LS D-TYPE POS-EDGE-TRIG	01295	SN74LS74AN
A15U19	1820-1282	3	3	IC FF TTL LS J-K BAR POS-EDGE-TRIG	01295	SN74LS109AN
A15U20	1820-1199	1	1	IC INV TTL LS HEX 1-INP	01295	SN74LS04N
A15U21	1820-1144	6	6	IC GATE TTL LS NOR QUAD 2-INP	01295	SN74LS02N
A15U22	1820-1997	7	3	IC FF TTL LS D-TYPE POS-EDGE-TRIG PRL-IN	34335	AM74LS374AP
A15U23	05342-80006	3	1	ROM-PROGRAMMED	28480	05342-80006
A15U24	1820-1144	6	6	IC GATE TTL LS NOR QUAD 2-INP	01295	SN74LS02N
A15U25	1820-1997	7	7	IC FF TTL LS D-TYPE POS-EDGE-TRIG PRL-IN	34335	AM74LS374AP
A15U26	05342-80007	4	1	ROM-PROGRAMMED	28480	05342-80007
A15U27	1820-1112	8	8	IC FF TTL LS D-TYPE POS-EDGE-TRIG	01295	SN74LS74AN
A15U28	1820-1997	7	7	IC FF TTL LS D-TYPE POS-EDGE-TRIG PRL-IN	34335	AM74LS374AP
A15U29	1820-1689	4	4	IC TRANSCEIVER TTL INSTR-BUS IEEE-488	04713	MC3446AP
A15U30	1820-1202	7	1	IC GATE TTL LS NAND TPL 3-INP	01295	SN74LS10N
A15U31	1820-1689	4	4	IC TRANSCEIVER TTL INSTR-BUS IEEE-488	04713	MC3446AP
A15U32	1820-1689	4	4	IC TRANSCEIVER TTL INSTR-BUS IEEE-488	04713	MC3446AP
A15U33	1820-1197	9	1	IC GATE TTL LS NAND QUAD 2-INP	01295	SN74LS00N
A15U34	1820-1689	4	4	IC TRANSCEIVER TTL INSTR-BUS IEEE-488	04713	MC3446AP
A15U35	1820-0904	4	1	IC COMPTR TTL L MAGTD 5-BIT	07263	93L24PC
A15U36	1820-1144	6	6	IC GATE TTL LS NOR QUAD 2-INP	01295	SN74LS02N
A15U37	1820-1112	8	8	IC FF TTL LS D-TYPE POS-EDGE-TRIG	01295	SN74LS74AN
A15XU11	1200-0473		1	SOCKET-IC 16-CONT DIP-SLDR	28480	1200-0473

See introduction to this section for ordering information
*Indicates factory selected value

Table 6-2. Replaceable Parts (Continued)

Reference Designation	HP Part Number	C D	Qty	Description	Mfr Code	Mfr Part Number
A16	05370-60016	7	1	BOARD ASSY- ARM INTERFACE (SERIES 2332)	28480	05370-60016
A16C1 - C3	0160-3879	7	10	CAPACITOR-FXD .01UF +20% 100VDC CER	28480	0160-3879
A16C4	0180-4136		1	CAPACITOR-FXD 10UF+10% 20VDC TA	56289	150D106X9020B2
A16C5 - C11	0160-4040			CAPACITOR-FXD .01UF +20% 100VDC CER	28480	0160-4040
A16C12 - C13	0180-0106	9	2	CAPACITOR-FXD 60UF+20% 6VDC TA	56289	150D606X0006B2
A16C14 - C15	0160-4040	6	2	CAPACITOR-FXD 1000PF +20% 100VDC CER	28480	0160-4040
A16C16	0160-4832	4	1	CAPACITOR-FXD .01UF +10% 100VDC CER	28480	0160-4832
A16CR1	1901-0040	1	1	DIODE-SWITCHING 30V 50MA 2NS DO-35	28480	1901-0040
A16J1	1200-0614	9	1	SOCKET-RLY 18-CONT DIP-SLDR	28480	1200-0614
A16L1 - L2	9100-1788	6	2	CORE-FERRITE CHOKE-WIDEBAND; IMP:>680	28480	9100-1788
A16MP1 - MP2	0403-0189	2	2	EXTR-PC BD BLK POLYC .062-BD-THKNS	28480	0403-0189
A16MP3 - MP4	1480-0116	8	2	PIN-GRV .062-IN-DIA .25-IN-LG STL	28480	1480-0116
A16R1	0698-3437	2	1	RESISTOR 133 1% .125W F TC=0+100	24546	C4-1/8-T0-133R-F
A16R2	0757-0407	6	2	RESISTOR 200 1% .125W F TC=0+100	24546	C4-1/8-T0-201-F
A16R3	0698-3152	8	4	RESISTOR 3.48K 1% .125W F TC=0+100	24546	C4-1/8-T0-3481-F
A16R4	0698-3152	8		RESISTOR 3.48K 1% .125W F TC=0+100	24546	C4-1/8-T0-3481-F
A16R5	1810-0080	6	2	NETWORK-RES 8-SIP500.0 OHM X 7	28480	1810-0080
A16R6	0698-3152	8		RESISTOR 3.48K 1% .125W F TC=0+100	24546	C4-1/8-T0-3481-F
A16R7	0698-3456	5	1	RESISTOR 287K 1% .125W F TC=0+100	24546	C4-1/8-T0-2873-F
A16R8	0698-3152	8		RESISTOR 3.48K 1% .125W F TC=0+100	24546	C4-1/8-T0-3481-F
A16R9	0698-3155	1	1	RESISTOR 4.64K 1% .125W F TC=0+100	24546	C4-1/8-T0-4641-F
A16R10	0757-0280	3	2	RESISTOR 1K 1% .125W F TC=0+100	24546	C4-1/8-T0-1001-F
A16R11	0757-0439	4	1	RESISTOR 6.81K 1% .125W F TC=0+100	24546	C4-1/8-T0-6811-F
A16R12	0757-0280	3		RESISTOR 1K 1% .125W F TC=0+100	24546	C4-1/8-T0-1001-F
A16R13	0757-0407	6		RESISTOR 200 1% .125W F TC=0+100	24546	C4-1/8-T0-201-F
A16R14	0757-0394	0	3	RESISTOR 51.1 1% .125W F TC=0+100	24546	C4-1/8-T0-51R1-F
A16R15	1810-0176	1	4	NETWORK-RES 5-SIP4.7K OHM X 4	28480	1810-0176
A16R16	1810-0080	6		NETWORK-RES 8-SIP500.0 OHM X 7	28480	1810-0080
A16R17 - R19	1810-0176	1		NETWORK-RES 5-SIP4.7K OHM X 4	28480	1810-0176
A16R20 - R21	0757-0394	0		RESISTOR 51.1 1% .125W F TC=0+100	24546	C4-1/8-T0-51R1-F
A16S1	3101-1856	5	1	SWITCH-SL 8-1A DIP-SLIDE-ASSY .1A 50VDC	28480	3101-1856
A16TP1 - TP2	0360-1682	0	2	TERMINAL-STUD SGL-TUR PRESS-MTG	28480	0360-1682
A16U1	1826-0138	8	1	IC COMPARATOR GP QUAD 14-DIP-P PKG	01295	LM339N
A16U2	1820-1195	7	6	IC FF TTL LS D-TYPE POS-EDGE-TRIG COM	01295	SN74LS175N
A16U3	1820-1195	7		IC FF TTL LS D-TYPE POS-EDGE-TRIG COM	01295	SN74LS175N
A16U4	1820-1207	2	1	IC GATE TTL LS NAND 8-INP	01295	SN74LS30N
A16U5	1820-1195	7		IC FF TTL LS D-TYPE POS-EDGE-TRIG COM	01295	SN74LS175N
A16U6	1820-1199	1	1	IC INV TTL LS HEX 1-INP	01295	SN74LS04N
A16U7	1820-1195	7		IC FF TTL LS D-TYPE POS-EDGE-TRIG COM	01295	SN74LS175N
A16U8	1820-0068	1	1	IC GATE TTL NAND TPL 3-INP	01295	SN7410N
A16U9	1820-1195	7		IC FF TTL LS D-TYPE POS-EDGE-TRIG COM	01295	SN74LS175N
A16U10	5080-8624		1	IC GATE TTL NAND QUAD 2-INP	28480	5080-8624
A16U11	1820-1195	7		IC FF TTL LS D-TYPE POS-EDGE-TRIG COM	01295	SN74LS175N
A16U12	1820-1216	3	2	IC DCDR TTL LS 3-TO-8-LINE 3-INP	01295	SN74LS138N
A16U13	1820-1112	8	2	IC FF TTL LS D-TYPE POS-EDGE-TRIG	01295	SN74LS74AN
A16U14	1820-1216	3		IC DCDR TTL LS 3-TO-8-LINE 3-INP	01295	SN74LS138N
A16U15	1820-1439	2	4	IC MUXR/DATA-SEL TTL LS 2-TO-1-LINE	01295	SN74LS258BN
A16U16	1820-1112	8		IC FF TTL LS D-TYPE POS-EDGE-TRIG	01295	SN74LS74AN
A16U17	1820-1439	2		IC MUXR/DATA-SEL TTL LS 2-TO-1-LINE	01295	SN74LS258BN
A16U18	1820-1443	8	3	IC CNTR TTL LS BIN ASYNCHRO	01295	SN74LS293N
A16U19	1820-1439	2		IC MUXR/DATA-SEL TTL LS 2-TO-1-LINE	01295	SN74LS258BN
A16U20	1820-1443	8		IC CNTR TTL LS BIN ASYNCHRO	01295	SN74LS293N
A16U21	1820-1439	2		IC MUXR/DATA-SEL TTL LS 2-TO-1-LINE	01295	SN74LS258BN
A16U22	1820-1443	8		IC CNTR TTL LS BIN ASYNCHRO	01295	SN74LS293N

See introduction to this section for ordering information
*Indicates factory selected value

Table 6-2. Replaceable Parts (Continued)

Reference Designation	HP Part Number	C D	Qty	Description	Mfr Code	Mfr Part Number
A17	05370-60017	8	1	BOARD ASSEMBLY-COUNT CHAIN (SERIES 1832)	28480	05370-60017
A17C1 - C8	0160-3879	7	14	CAPACITOR-FXD .01UF +-20% 100VDC CER	28480	0160-3879
A17C9	0180-0106	9	2	CAPACITOR-FXD 60UF+-20% 6VDC TA	56289	150D606X0006B2
A17C10	0160-3879	7		CAPACITOR-FXD .01UF +-20% 100VDC CER	28480	0160-3879
A17C11	0160-3879	7		CAPACITOR-FXD .01UF +-20% 100VDC CER	28480	0160-3879
A17C12	0160-3879	7		CAPACITOR-FXD .01UF +-20% 100VDC CER	28480	0160-3879
A17C13 - C15	0160-4040	6	8	CAPACITOR-FXD 1000PF +-20% 100VDC CER	28480	0160-4040
A17C16	0180-0106	9		CAPACITOR-FXD 60UF+-20% 6VDC TA	56289	150D606X0006B2
A17C17 - C20	0160-4040	6		CAPACITOR-FXD 1000PF +-20% 100VDC CER	28480	0160-4040
A17C21 - C23	0160-3879	7		CAPACITOR-FXD .01UF +-20% 100VDC CER	28480	0160-3879
A17C24	0160-4040	6		CAPACITOR-FXD 1000PF +-20% 100VDC CER	28480	0160-4040
A17DS1	1990-0486	6	1	LED-LAMP, RED	28480	5082-4684
A17L1	9100-1788	6	2	CORE-FERRITE CHOKE-WIDEBAND; IMP:>680	28480	9100-1788
A17L2 - L4	9100-2248	5	3	INDUCTOR RF-CH-MLD 120NH 10% .105DX.26LG	28480	9100-2248
A17L5	9100-1788	6		CORE-FERRITE CHOKE-WIDEBAND; IMP:>680	28480	9100-1788
A17MP1 - MP2	0403-0189	2	2	EXTR-PC BD BLK POLYC .062-BD-THKNS	28480	0403-0189
A17MP3 - MP4	1480-0116	8	2	PIN-GRV .062-IN-DIA .25-IN-LG STL	28480	1480-0116
A17R1	0698-0082	7	1	RESISTOR 464 1% .125W F TC=0+-100	24546	C4-1/8-T0-4640-F
A17R2	0698-3155	1	1	RESISTOR 4.64K 1% .125W F TC=0+-100	24546	C4-1/8-T0-4641-F
A17R3	0757-0420	3	1	RESISTOR 750 1% .125W F TC=0+-100	24546	C4-1/8-T0-751-F
A17R4	0757-1094	9	1	RESISTOR 1.47K 1% .125W F TC=0+-100	24546	C4-1/8-T0-1471-F
A17R5	0757-0274	5	1	RESISTOR 1.21K 1% .125W F TC=0+-100	24546	C4-1/8-T0-1211-F
A17R6 - R9	1810-0176	1	5	NETWORK-RES 5-SIP4.7K OHM X 4	28480	1810-0176
A17R10 - R21	0698-7249	2	12	RESISTOR 3.48K 1% .05W F TC=0+-100	24546	C3-1/8-T0-3481-F
A17R22	0698-7243	6	12	RESISTOR 1.96K 1% .05W F TC=0+-100	24546	C3-1/8-T0-1961-F
A17R23	0698-7236	7	17	RESISTOR 1K 1% .05W F TC=0+-100	24546	C3-1/8-T0-1001-F
A17R24	0698-7243	6		RESISTOR 1.96K 1% .05W F TC=0+-100	24546	C3-1/8-T0-1961-F
A17R25	0698-7236	7		RESISTOR 1K 1% .05W F TC=0+-100	24546	C3-1/8-T0-1001-F
A17R26	0698-7243	6		RESISTOR 1.96K 1% .05W F TC=0+-100	24546	C3-1/8-T0-1961-F
A17R27	0698-7236	7		RESISTOR 1K 1% .05W F TC=0+-100	24546	C3-1/8-T0-1001-F
A17R28	0698-7243	6		RESISTOR 1.96K 1% .05W F TC=0+-100	24546	C3-1/8-T0-1961-F
A17R29	0698-7236	7		RESISTOR 1K 1% .05W F TC=0+-100	24546	C3-1/8-T0-1001-F
A17R30	0698-7243	6		RESISTOR 1.96K 1% .05W F TC=0+-100	24546	C3-1/8-T0-1961-F
A17R31	0698-7236	7		RESISTOR 1K 1% .05W F TC=0+-100	24546	C3-1/8-T0-1001-F
A17R32	0698-7243	6		RESISTOR 1.96K 1% .05W F TC=0+-100	24546	C3-1/8-T0-1961-F
A17R33 - R39	0698-7236	7		RESISTOR 1K 1% .05W F TC=0+-100	24546	C3-1/8-T0-1001-F
A17R40	0698-7243	6		RESISTOR 1.96K 1% .05W F TC=0+-100	24546	C3-1/8-T0-1961-F
A17R41	0698-7229	8	6	RESISTOR 511 1% .05W F TC=0+-100	24546	C3-1/8-T0-511R-F
A17R42	0698-7243	6		RESISTOR 1.96K 1% .05W F TC=0+-100	24546	C3-1/8-T0-1961-F
A17R43	0698-7229	8		RESISTOR 511 1% .05W F TC=0+-100	24546	C3-1/8-T0-511R-F
A17R44	0698-7243	6		RESISTOR 1.96K 1% .05W F TC=0+-100	24546	C3-1/8-T0-1961-F
A17R45	0698-7229	8		RESISTOR 511 1% .05W F TC=0+-100	24546	C3-1/8-T0-511R-F
A17R46	0698-7236	7		RESISTOR 1K 1% .05W F TC=0+-100	24546	C3-1/8-T0-1001-F
A17R47	0698-7243	6		RESISTOR 1.96K 1% .05W F TC=0+-100	24546	C3-1/8-T0-1961-F
A17R48	0698-7229	8		RESISTOR 511 1% .05W F TC=0+-100	24546	C3-1/8-T0-511R-F
A17R49	0698-7243	6		RESISTOR 1.96K 1% .05W F TC=0+-100	24546	C3-1/8-T0-1961-F
A17R50	0698-7229	8		RESISTOR 511 1% .05W F TC=0+-100	24546	C3-1/8-T0-511R-F
A17R51	0698-7243	6		RESISTOR 1.96K 1% .05W F TC=0+-100	24546	C3-1/8-T0-1961-F
A17R52	0698-7229	8		RESISTOR 511 1% .05W F TC=0+-100	24546	C3-1/8-T0-511R-F
A17R53 - R55	0698-7236	7		RESISTOR 1K 1% .05W F TC=0+-100	24546	C3-1/8-T0-1001-F
A17R56 - R58	0698-7207	2	3	RESISTOR 61.9 1% .05W F TC=0+-100	24546	C3-1/8-T0-61R9-F
A17R59 - R60	0757-0280	3	2	RESISTOR 1K 1% .125W F TC=0+-100	24546	C4-1/8-T0-1001-F
A17R61	0698-7236	7		RESISTOR 1K 1% .05W F TC=0+-100	24546	C3-1/8-T0-1001-F
A17R62	1810-0176	1		NETWORK-RES 5-SIP4.7K OHM X 4	28480	1810-0176
A17TP1 - TP14	0360-1682	0	14	TERMINAL-STUD SGL-TUR PRESS-MTG	28480	0360-1682
A17U1	1820-1212	9	2	IC FF TTL LS J-K NEG-EDGE-TRIG	01295	SN74LS112AN
A17U2 - U4	1820-1443	8	5	IC CNTR TTL LS BIN ASYNCHRO	01295	SN74LS293N
A17U5	1820-1439	2	6	IC MUXR/DATA-SEL TTL LS 2-T0-1-LINE	01295	SN74LS258BN

See introduction to this section for ordering information
*Indicates factory selected value

Table 6-2. Replaceable Parts (Continued)

Reference Designation	HP Part Number	C D	Qty	Description	Mfr Code	Mfr Part Number
A17U6	1820-1439	2	5	IC MUXR/DATA-SEL TTL LS 2-TO-1-LINE	01295	SN74LS258BN
A17U7	1820-1441	6		IC ADDR TTL LS BIN FULL ADDR 4-BIT	01295	SN74LS283N
A17U8	1820-1439	2		IC MUXR/DATA-SEL TTL LS 2-TO-1-LINE	01295	SN74LS258BN
A17U9	1820-1439	2		IC MUXR/DATA-SEL TTL LS 2-TO-1-LINE	01295	SN74LS258BN
A17U10	1820-1441	6		IC ADDR TTL LS BIN FULL ADDR 4-BIT	01295	SN74LS283N
A17U11	1820-1439	2	1	IC MUXR/DATA-SEL TTL LS 2-TO-1-LINE	01295	SN74LS258BN
A17U12	1820-1439	2		IC MUXR/DATA-SEL TTL LS 2-TO-1-LINE	01295	SN74LS258BN
A17U13	1820-1441	6		IC ADDR TTL LS BIN FULL ADDR 4-BIT	01295	SN74LS283N
A17U14	1820-1199	1		IC INV TTL LS HEX 1-INP	01295	SN74LS04N
A17U15	1820-1441	6		IC ADDR TTL LS BIN FULL ADDR 4-BIT	01295	
A17U16	1820-1212	9	1	IC FF TTL LS J-K NEG-EDGE-TRIG	01295	SN74LS112AN
A17U17	1820-1443	8		IC CNTR TTL LS BIN ASYNCHRO	01295	SN74LS293N
A17U18	1820-1441	6		IC ADDR TTL LS BIN FULL ADDR 4-BIT	01295	SN74LS283N
A17U19	1820-1443	8		IC CNTR TTL LS BIN ASYNCHRO	01295	SN74LS293N
A17U20	1820-3125			IC XLTR ECL ECL-TO-TTL QUAD 2-INP	04713	MC10125L
A17U21 - U23	1826-0138	8	3	IC COMPARATOR GP QUAD 14-DIP-P PKG	01295	LM339N
A17U24	1820-0817	8	3	IC FF ECL D-M/S DUAL	04713	MC10131P
A17U25	1820-0817	8		IC FF ECL D-M/S DUAL	04713	MC10131P
A17U26	1820-0817	8	3	IC FF ECL D-M/S DUAL	04713	MC10131P
A17U27 - U29	1820-1225	4		IC FF ECL D-M/S DUAL	04713	MC10231P
A17U30	1820-0801	0		1	IC GATE ECL OR-NOR QUAD 2-INP	04713
A17U31	1820-1224	3	1	IC RCVR ECL LINE RCVR TPL 2-INP	04713	MC10216P

See introduction to this section for ordering information
*Indicates factory selected value

Table 6-2. Replaceable Parts (Continued)

Reference Designation	HP Part Number	C D	Qty	Description	Mfr Code	Mfr Part Number
A18	05370-60218	1	1	BD ASSY-DAC/NO LOGIC (SERIES 2316)	28480	05370-60218
A18C1	0160-3879	7	12	CAPACITOR-FXD .01UF +20% 100VDC CER	28480	0160-3879
A18C2	0160-2308	5	2	CAPACITOR-FXD 36PF +5% 300VDC MICA	28480	0160-2308
A18C3	0160-2308	5		CAPACITOR-FXD 36PF +5% 300VDC MICA	28480	0160-2308
A18C4	0160-3879	7		CAPACITOR-FXD .01UF +20% 100VDC CER	28480	0160-3879
A18C5	0160-3879	7		CAPACITOR-FXD .01UF +20% 100VDC CER	28480	0160-3879
A18C6	0180-4133	0	7	CAPACITOR-FXD 15UF+10% 20VDC TA	56289	150D156X9020B2
A18C7	0160-3879	7		CAPACITOR-FXD .01UF +20% 100VDC CER	28480	0160-3879
A18C8	0180-4133	0		CAPACITOR-FXD 15UF+10% 20VDC TA	56289	150D156X9020B2
A18C9				NOT ASSIGNED		
A18C10	0160-3879	7		CAPACITOR-FXD .01UF +20% 100VDC CER	28480	0160-3879
A18C11	0160-3879	7		CAPACITOR-FXD .01UF +20% 100VDC CER	28480	0160-3879
A18C12	0160-3879	7		CAPACITOR-FXD .01UF +20% 100VDC CER	28480	0160-3879
A18C13	0180-4133	0		CAPACITOR-FXD 15UF+10% 20VDC TA	56289	150D156X9020B2
A18C14	0160-3879	7		CAPACITOR-FXD .01UF +20% 100VDC CER	28480	0160-3879
A18C15	0180-4133	0		CAPACITOR-FXD 15UF+10% 20VDC TA	56289	150D156X9020B2
A18C16	0160-3879	7		CAPACITOR-FXD .01UF +20% 100VDC CER	28480	0160-3879
A18C17	0160-3879	7		CAPACITOR-FXD .01UF +20% 100VDC CER	28480	0160-3879
A18C18	0180-4133	0		CAPACITOR-FXD 15UF+10% 20VDC TA	56289	150D156X9020B2
A18C19	0160-3879	7		CAPACITOR-FXD .01UF +20% 100VDC CER	28480	0160-3879
A18C20	0180-4133	0		CAPACITOR-FXD 15UF+10% 20VDC TA	56289	150D156X9020B2
A18C21	0121-0059	7	1	CAPACITOR-V TRMR-CER 2-8PF 350V PC-MTG	52763	304324 2/8PF NPO
A18C22	0180-4133	0		CAPACITOR-FXD 15UF+10% 20VDC TA	56289	150D156X9020B2
A18CR1				NOT ASSIGNED		
A18CR2	1902-0041	4	1	DIODE-ZNR 5.11V 5% DO-35 PD=.4W	07263	1N751A
A18K1	0490-1063	6	1	RELAY-REED 2A 500MA 50VDC 5VDC-COIL 10VA	28480	0490-1063
A18L1	9100-2285	0	2	INDUCTOR RF-CH-MLD 560UH 10% .105DX.26LG	28480	9100-2285
A18L2	9100-2285	0		INDUCTOR RF-CH-MLD 560UH 10% .105DX.26LG	28480	9100-2285
A18L3	9140-0933	5	2	INDUCTOR 50NH 20% .105DX.26LG Q=40	28480	9140-0933
A18L4	9100-1788	6	5	CORE-FERRITE CHOKE-WIDEBAND; IMP:>680	28480	9100-1788
A18L5	9100-1788	6		CORE-FERRITE CHOKE-WIDEBAND; IMP:>680	28480	9100-1788
A18L6	9100-2248	5	2	INDUCTOR RF-CH-MLD 120NH 10% .105DX.26LG	28480	9100-2248
A18L7	9100-1788	6		CORE-FERRITE CHOKE-WIDEBAND; IMP:>680	28480	9100-1788
A18L8	9100-2248	5		INDUCTOR RF-CH-MLD 120NH 10% .105DX.26LG	28480	9100-2248
A18L9	9100-1788	6		CORE-FERRITE CHOKE-WIDEBAND; IMP:>680	28480	9100-1788
A18L10	9100-1788	6		CORE-FERRITE CHOKE-WIDEBAND; IMP:>680	28480	9100-1788
A18L11	9140-0933	5		INDUCTOR 50NH 20% .105DX.26LG Q=40	28480	9140-0933
A18MP1 - MP2	0403-0189	2	2	EXTR-PC BD BLK POLYC .062-BD-THKNS	28480	0403-0189
A18MP3 - MP4	1480-0116	8	2	PIN-GRV .062-IN-DIA .25-IN-LG STL	28480	1480-0116
A18Q1 - Q2	1853-0015	7	2	TRANSISTOR PNP SI PD=200MW FT=500MHZ	28480	1853-0015
A18R1	0698-3150	6	12	RESISTOR 2.37K 1% .125W F TC=0+100	24546	C4-1/8-T0-2371-F
A18R2	0698-3150	6		RESISTOR 2.37K 1% .125W F TC=0+100	24546	C4-1/8-T0-2371-F
A18R3	0698-3155	1	7	RESISTOR 4.64K 1% .125W F TC=0+100	24546	C4-1/8-T0-4641-F
A18R4	2100-3350	5	6	RESISTOR-TRMR 200 10% C SIDE-ADJ 1-TRN	28480	2100-3350
A18R5	2100-3350	5		RESISTOR-TRMR 200 10% C SIDE-ADJ 1-TRN	28480	2100-3350
A18R6	0698-3155	1		RESISTOR 4.64K 1% .125W F TC=0+100	24546	C4-1/8-T0-4641-F
A18R7	0698-3155	1		RESISTOR 4.64K 1% .125W F TC=0+100	24546	C4-1/8-T0-4641-F
A18R8	2100-3350	5		RESISTOR-TRMR 200 10% C SIDE-ADJ 1-TRN	28480	2100-3350
A18R9	0698-3155	1		RESISTOR 4.64K 1% .125W F TC=0+100	24546	C4-1/8-T0-4641-F
A18R10	0698-3155	1		RESISTOR 4.64K 1% .125W F TC=0+100	24546	C4-1/8-T0-4641-F
A18R11	0698-0084	9	2	RESISTOR 2.15K 1% .125W F TC=0+100	24546	C4-1/8-T0-2151-F
A18R12	0757-0401	0	1	RESISTOR 100 1% .125W F TC=0+100	24546	C4-1/8-T0-101-F
A18R13	0757-0278	9	1	RESISTOR 1.78K 1% .125W F TC=0+100	24546	C4-1/8-T0-1781-F
A18R14	0757-0274	5	3	RESISTOR 1.21K 1% .125W F TC=0+100	24546	C4-1/8-T0-1211-F
A18R15	2100-3350	5		RESISTOR-TRMR 200 10% C SIDE-ADJ 1-TRN	28480	2100-3350
A18R16	0757-0274	5		RESISTOR 1.21K 1% .125W F TC=0+100	24546	C4-1/8-T0-1211-F
A18R17	0757-0416	7	6	RESISTOR 511 1% .125W F TC=0+100	24546	C4-1/8-T0-511R-F
A18R18	0698-3150	6		RESISTOR 2.37K 1% .125W F TC=0+100	24546	C4-1/8-T0-2371-F
A18R19	0698-3150	6		RESISTOR 2.37K 1% .125W F TC=0+100	24546	C4-1/8-T0-2371-F
A18R20	2100-3350	5		RESISTOR-TRMR 200 10% C SIDE-ADJ 1-TRN	28480	2100-3350

See introduction to this section for ordering information
*Indicates factory selected value

Table 6-2. Replaceable Parts (Continued)

Reference Designation	HP Part Number	C D	Qty	Description	Mfr Code	Mfr Part Number
A18R21 - R22	0698-3150	6		RESISTOR 2.37K 1% .125W F TC=0+100	24546	C4-1/8-T0-2371-F
A18R23	0757-0442	9	1	RESISTOR 10K 1% .125W	28480	0757-0442
A18R24	0757-0421	4	3	RESISTOR 825 1% .125W F TC=0+100	24546	C4-1/8-T0-825R-F
A18R25	0698-3150	6		RESISTOR 2.37K 1% .125W F TC=0+100	24546	C4-1/8-T0-2371-F
A18R26	0757-0421	4		RESISTOR 825 1% .125W F TC=0+100	24546	C4-1/8-T0-825R-F
A18R27	0757-0421	4		RESISTOR 825 1% .125W F TC=0+100	24546	C4-1/8-T0-825R-F
A18R28	0698-3150	6		RESISTOR 2.37K 1% .125W F TC=0+100	24546	C4-1/8-T0-2371-F
A18R29	2100-3350	5		RESISTOR-TRMR 200 10% C SIDE-ADJ 1-TRN	28480	2100-3350
A18R30	0698-3150	6		RESISTOR 2.37K 1% .125W F TC=0+100	24546	C4-1/8-T0-2371-F
A18R31	0757-0422		2	RESISTOR 909 1% .5W F TC=0+100	28480	0757-0422
A18R32	0757-0346	2	1	RESISTOR 10 1% .125W F TC=0+100	24546	C4-1/8-T0-10R0-F
A18R33	0757-0819	4		RESISTOR 909 1% .5W F TC=0+100	28480	0757-0819
A18R34	0698-0084	6	2	RESISTOR 2.15K 1% .125W F TC=0+100	28480	0698-0084
A18R35	0698-3150	6		RESISTOR 2.37K 1% .125W F TC=0+100	24546	C4-1/8-T0-2371-F
A18R36	0698-3150	6		RESISTOR 2.37K 1% .125W F TC=0+100	24546	C4-1/8-T0-2371-F
A18R37				NOT ASSIGNED		
A18R38	0698-3155	1		RESISTOR 4.64K 1% .125W F TC=0+100	24546	C4-1/8-T0-4641-F
A18R39	0698-3155	1		RESISTOR 4.64K 1% .125W F TC=0+100	24546	C4-1/8-T0-4641-F
A18R40				NOT ASSIGNED		
A18R41	0698-0085	0	1	RESISTOR 2.61K 1%	28480	0698-0085
A18R42	0698-3442	9	2	RESISTOR 237 1% .125W F TC=0+100	24546	C4-1/8-T0-237R-F
A18R43	0698-0082	7	1	RESISTOR 464 1% .125W F TC=0+100	24546	C4-1/8-T0-4640-F
A18R44	1810-0123	8	2	NETWORK-RES 8-SIP330.0 OHM X 7	28480	1810-0123
A18R45	0757-0416	7		RESISTOR 511 1% .125W F TC=0+100	24546	C4-1/8-T0-511R-F
A18R46	0757-0276	7	2	RESISTOR 61.9 1% .125W F TC=0+100	24546	C4-1/8-T0-6192-F
A18R47	0757-0416	7		RESISTOR 511 1% .125W F TC=0+100	24546	C4-1/8-T0-511R-F
A18R48	0698-3442	9		RESISTOR 237 1% .125W F TC=0+100	24546	C4-1/8-T0-237R-F
A18R49	0757-0416	7		RESISTOR 511 1% .125W F TC=0+100	24546	C4-1/8-T0-511R-F
A18R50	0757-0276	7		RESISTOR 61.9 1% .125W F TC=0+100	24546	C4-1/8-T0-6192-F
A18R51	0757-0416	7		RESISTOR 511 1% .125W F TC=0+100	24546	C4-1/8-T0-511R-F
A18R52	1810-0055	5	1	NETWORK-RES 9-SIP10.0K OHM X 8	28480	1810-0055
A18R53	1810-0123	8		NETWORK-RES 8-SIP330.0 OHM X 7	28480	1810-0123
A18R54	0757-0276	6	1	RESISTOR 61.9 1% .125W F TC=0+100	24546	C4-1/8-T0-6192-F
A18R55	0757-0280	3	1	RESISTOR 1K 1% .125W F TC=0+100	24546	C4-1/8-T0-1001-F
A18R56	0698-3439	4	2	RESISTOR 178 1% .125W F TC=0+100	24546	C4-1/8-T0-178R-F
A18R57	0698-3439	4		RESISTOR 178 1% .125W F TC=0+100	24546	C4-1/8-T0-178R-F
A18R58	0698-3150	6		RESISTOR 2.37K 1% .125W F TC=0+100	24546	C4-1/8-T0-2371-F
A18R59	0757-0274	5		RESISTOR 1.21K 1% .125W F TC=0+100	24546	C4-1/8-T0-1211-F
A18TP1 - TP15	0360-1682	0	15	TERMINAL-STUD SGL-TUR PRESS-MTG	28480	0360-1682
A18U1	1820-1255	0	1	IC INV TTL HEX 1-INP	27014	DM8098N
A18U2	1820-1195	7	6	IC FF TTL LS D-TYPE POS-EDGE-TRIG COM	01295	SN74LS175N
A18U3	1820-1195	7		IC FF TTL LS D-TYPE POS-EDGE-TRIG COM	01295	SN74LS175N
A18U4	1820-1195	7		IC FF TTL LS D-TYPE POS-EDGE-TRIG COM	01295	SN74LS175N
A18U5	1820-1195	7		IC FF TTL LS D-TYPE POS-EDGE-TRIG COM	01295	SN74LS175N
A18U6	1820-1195	7		IC FF TTL LS D-TYPE POS-EDGE-TRIG COM	01295	SN74LS175N
A18U7	1820-1195	7		IC FF TTL LS D-TYPE POS-EDGE-TRIG COM	01295	SN74LS175N
A18U8	1826-0188	8	2	IC CONV 8-B-D/A 16-DIP-C PKG	04713	MC1408L-8
A18U9	1826-0188	8		IC CONV 8-B-D/A 16-DIP-C PKG	04713	MC1408L-8
A18U10				NOT ASSIGNED		
A18U11	1826-0161	7	1	IC OP AMP GP QUAD 14-DIP-P PKG	04713	MLM324P
A18U12	1826-0138	8	1	IC COMPARATOR GP QUAD 14-DIP-P PKG	01295	LM339N
A18U13	1820-1313	1	2	IC MULTIPLXR 2-CHAN-ANLG TRIPLE 16-DIP-P	3L585	CD4053BE
A18U14	1820-1313	1		IC MULTIPLXR 2-CHAN-ANLG TRIPLE 16-DIP-P	3L585	CD4053BE
A18U15	1820-1224	3	1	IC RCVR ECL LINE RCVR TPL 2-INP	04713	MC10216P
A18U16	1820-0796	2	1	IC GATE ECL NOR QUAD 2-INP	04713	MC1662L
A18U17	1820-1225	4	2	IC FF ECL D-M/S DUAL	04713	MC10231P
A18U18	1820-0802	1	1	IC GATE ECL NOR QUAD 2-INP	04713	MC10102P
A18U19	1820-1225	4		IC FF ECL D-M/S DUAL	04713	MC10231P

See introduction to this section for ordering information
*Indicates factory selected value

Table 6-2. Replaceable Parts (Continued)

Reference Designation	HP Part Number	C D	Qty	Description	Mfr Code	Mfr Part Number
A19/A20	05370-60119	1	2	BOARD ASSEMBLY-INTERPOLATOR(SERIES 2732)	28480	05370-60119
A19C1	0160-3879	7	19	CAPACITOR-FXD .01UF +20% 100VDC CER	28480	0160-3879
A19C2	0160-3879	7		CAPACITOR-FXD .01UF +20% 100VDC CER	28480	0160-3879
A19C3	0121-0105	4	1	CAPACITOR-V TRMR-CER 9-35PF 200V PC-MTG	52763	304324 9/35PF N650
A19C4	0160-2204	0	2	CAPACITOR-FXD 100PF +5% 300VDC MICA	28480	0160-2204
A19C5	0160-0145	4	1	CAPACITOR-FXD 82PF +2% 100VDC MICA	28480	0160-0145
A19C6	0180-4132	9	2	CAPACITOR-FXD 6.8UF+10% 35VDC TA	56289	150D685X9035B2
A19C7 - C13	0160-3879	7		CAPACITOR-FXD .01UF +20% 100VDC CER	28480	0160-3879
A19C14	0160-0154	5	2	CAPACITOR-FXD 2200PF +10% 200VDC POLYE	28480	0160-0154
A19C15 - C19	0160-3879	7		CAPACITOR-FXD .01UF +20% 100VDC CER	28480	0160-3879
A19C20	0140-0198	5	2	CAPACITOR-FXD 200PF +5% 300VDC MICA	72136	DM15F201J0300WV1CR
A19C21	0140-0198	5		CAPACITOR-FXD 200PF +5% 300VDC MICA	72136	DM15F201J0300WV1CR
A19C22	0160-0154	5		CAPACITOR-FXD 2200PF +10% 200VDC POLYE	28480	0160-0154
A19C23	0160-2204	0		CAPACITOR-FXD 100PF +5% 300VDC MICA	28480	0160-2204
A19C24	0160-3879	7		CAPACITOR-FXD .01UF +20% 100VDC CER	28480	0160-3879
A19C25	0160-3879	7		CAPACITOR-FXD .01UF +20% 100VDC CER	28480	0160-3879
A19C26	0160-0182	9	1	CAPACITOR-FXD 47PF +5% 300VDC MICA	28480	0160-0182
A19C27 - 29	0160-3879	7		CAPACITOR-FXD .01UF +20% 100VDC CER	28480	0160-3879
A19C30	0180-4132	9		CAPACITOR-FXD 6.8UF+10% 35VDC TA	56289	150D685X9035B2
A19C31	0160-3879	7		CAPACITOR-FXD .01UF +20% 100VDC CER	28480	0160-3879
A19CR1	1901-0040	1	1	DIODE-SWITCHING 30V 50MA 2NS DO-35	28480	1901-0040
A19DL1	05370-80002	3	1	DELAY LINE ASSEMBLY- 10	28480	05370-80002
A19H1	2190-0124	4	1	WASHER-LK INTL T NO. 10 .195-IN-ID	28480	2190-0124
A19H2	2950-0078	9	1	NUT-HEX-DBL-CHAM 10-32-THD .067-IN-THK	28480	2950-0078
A19L1	9100-0346	0	3	INDUCTOR RF-CH-MLD 50NH 20% .105DX.26LG	28480	9100-0346
A19L2	9140-0142	8	2	INDUCTOR RF-CH-MLD 2.2UH 10% .105DX.26LG	28480	9140-0142
A19L3	9100-0346	0		INDUCTOR RF-CH-MLD 50NH 20% .105DX.26LG	28480	9100-0346
A19L4	9100-2269	0	1	INDUCTOR RF-CH-MLD 27UH 10% .105DX.26LG	28480	9100-2269
A19L5	9100-1788	6	3	CORE-FERRITE CHOKE-WIDEBAND; IMP:>680	28480	9100-1788
A19L6	9100-2248	5	1	INDUCTOR RF-CH-MLD 120NH 10% .105DX.26LG	28480	9100-2248
A19L7	9100-1788	6		CORE-FERRITE CHOKE-WIDEBAND; IMP:>680	28480	9100-1788
A19L8	9140-0142	8		INDUCTOR RF-CH-MLD 2.2UH 10% .105DX.26LG	28480	9140-0142
A19L9	9100-0346	0		INDUCTOR RF-CH-MLD 50NH 20% .105DX.26LG	28480	9100-0346
A19L10	9100-2276	9	2	INDUCTOR RF-CH-MLD 100UH 10% .105DX.26LG	28480	9100-2276
A19L11	9100-2276	9		INDUCTOR RF-CH-MLD 100UH 10% .105DX.26LG	28480	9100-2276
A19L12	9100-1788	6		CORE-FERRITE CHOKE-WIDEBAND; IMP:>680	28480	9100-1788
A19MP1 - MP2	0403-0189	2	2	EXTR-PC BD BLK POLYC .062-BD-THKNS	28480	0403-0189
A19MP3 - MP4	1480-0116	8	2	PIN-GRV .062-IN-DIA .25-IN-LG STL	28480	1480-0116
A19MP5 - MP6	2110-0269	0	2	FUSEHOLDER-CLIP TYPE.25D-FUSE	28480	2110-0269
A19Q1 - Q2	1854-0809	9	2	TRANSISTOR NPN SI PD=300MW FT=600MHZ	04713	2N709
A19R1	0698-7205	0	5	RESISTOR 51.1 1% .05W F TC=0+100	24546	C3-1/8-TO-51R1-F
A19R2	0757-0401	0	3	RESISTOR 100 1% .125W F TC=0+100	24546	C4-1/8-TO-101-F
A19R3	0698-7205	0		RESISTOR 51.1 1% .05W F TC=0+100	24546	C3-1/8-TO-51R1-F
A19R4	0698-3428	1	2	RESISTOR 14.7 1% .125W F TC=0+100	03888	PME55-1/8-TO-14R7-F
A19R5	2100-3350	5	1	RESISTOR-TRMR 200 10% C SIDE-ADJ 1-TRN	28480	2100-3350
A19R6	0757-0276	7	5	RESISTOR 61.9 1% .125W F TC=0+100	24546	C4-1/8-TO-6192-F
A19R7	0698-3446	3	2	RESISTOR 383 1% .125W F TC=0+100	24546	C4-1/8-TO-383R-F
A19R8	0698-3132	4	1	RESISTOR 261 1% .125W F TC=0+100	24546	C4-1/8-TO-2610-F
A19R9	0757-0394	0	4	RESISTOR 51.1 1% .125W F TC=0+100	24546	C4-1/8-TO-51R1-F
A19R10	0698-3132	4	3	RESISTOR 261 1% .125W F TC=0+100	24546	C4-1/8-TO-2610-F
A19R11	0698-7207	2	2	RESISTOR 61.9 1% .05W F TC=0+100	24546	C3-1/8-TO-61R9-F
A19R12	0698-0084	9	1	RESISTOR 2.15K 1% .125W F TC=0+100	24546	C4-1/8-TO-2151-F
A19R13	0698-3132	4		RESISTOR 261 1% .125W F TC=0+100	24546	C4-1/8-TO-2610-F
A19R14	0698-3132	4		RESISTOR 261 1% .125W F TC=0+100	24546	C4-1/8-TO-2610-F
A19R15	0757-0394	0		RESISTOR 51.1 1% .125W F TC=0+100	24546	C4-1/8-TO-51R1-F
A19R16	2100-3352	7	1	RESISTOR-TRMR 1K 10% C SIDE-ADJ 1-TRN	28480	2100-3352
A19R17	0698-7205	0		RESISTOR 51.1 1% .05W F TC=0+100	24546	C3-1/8-TO-51R1-F
A19R18	0698-7207	2		RESISTOR 61.9 1% .05W F TC=0+100	24546	C3-1/8-TO-61R9-F
A19R19	0698-7243	6	1	RESISTOR 1.96K 1% .05W F TC=0+100	24546	C3-1/8-TO-1961-F
A19R20	0757-1108	6	1	RESISTOR 300 1% .125W F TC=0+100	24546	C4-1/8-TO-301-F

See introduction to this section for ordering information
*Indicates factory selected value

Table 6-2. Replaceable Parts (Continued)

Reference Designation	HP Part Number	C D	Qty	Description	Mfr Code	Mfr Part Number	
A19R21	0757-0276	7	1	RESISTOR 61.9 1% .125W F TC=0+100	24546	C4-1/8-T0-6192-F	
A19R22	0698-3447	4		RESISTOR 422 1% .125W F TC=0+100	24546	C4-1/8-T0-422R-F	
A19R23	0757-0276	7		RESISTOR 61.9 1% .125W F TC=0+100	24546	C4-1/8-T0-6192-F	
A19R24 - R25				NOT ASSIGNED			
A19R26	0757-0276	7	1	RESISTOR 61.9 1% .125W F TC=0+100	24546	C4-1/8-T0-6192-F	
A19R27	0757-0394	0		RESISTOR 51.1 1% .125W F TC=0+100	24546	C4-1/8-T0-51R1-F	
A19R28	0698-3435	0		RESISTOR 38.3 1% .125W F TC=0+100	03888	PME55-1/8-T0-38R3-F	
A19R29	0698-3446	3		RESISTOR 383 1% .125W F TC=0+100	24546	C4-1/8-T0-383R-F	
A19R30	0698-3428	1		RESISTOR 14.7 1% .125W F TC=0+100	03888	PME55-1/8-T0-14R7-F	
A19R31				NOT ASSIGNED			
A19R32 - R33	0757-0283	6	2	RESISTOR 2K 1% .125W F TC=0+100	24546	C4-1/8-T0-2001-F	
A19R34	0757-0401	0		RESISTOR 100 1% .125W F TC=0+100	24546	C4-1/8-T0-101-F	
A19R35				NOT ASSIGNED			
A19R36	0757-0276	7	2	RESISTOR 61.9 1% .125W F TC=0+100	24546	C4-1/8-T0-6192-F	
A19R37	0757-0416	7		RESISTOR 511 1% .125W F TC=0+100	24546	C4-1/8-T0-511R-F	
A19R38	0757-0446	3		RESISTOR 15K 1% .125W F TC=0+100	24546	C4-1/8-T0-1502-F	
A19R39	0757-0280	3		RESISTOR 1K 1% .125W F TC=0+100	24546	C4-1/8-T0-1001-F	
A19R40				NOT ASSIGNED			
A19R41	0698-7236	7		1	RESISTOR 1K 1% .05W F TC=0+100	24546	C3-1/8-T0-1001-F
A19R42	0757-0416	7	RESISTOR 511 1% .125W F TC=0+100		24546	C4-1/8-T0-511R-F	
A19R43	0757-0280	3	RESISTOR 1K 1% .125W F TC=0+100		24546	C4-1/8-T0-1001-F	
A19R44	0698-3442	9	RESISTOR 237 1% .125W F TC=0+100		24546	C4-1/8-T0-237R-F	
A19R45	0757-0284	7	RESISTOR 150 1% .125W F TC=0+100		24546	C4-1/8-T0-151-F	
A19R46	0698-3442	9	RESISTOR 237 1% .125W F TC=0+100		24546	C4-1/8-T0-237R-F	
A19R47	0757-0346	2	RESISTOR 10 1% .125W F TC=0+100		24546	C4-1/8-T0-10R0-F	
A19R48	0757-0438	3	RESISTOR 5.11K 1% .125W F TC=0+100		24546	C4-1/8-T0-5111-F	
A19R49	0757-0446	3	RESISTOR 15K 1% .125W F TC=0+100		24546	C4-1/8-T0-1502-F	
A19R50	0757-0280	3	RESISTOR 1K 1% .125W F TC=0+100		24546	C4-1/8-T0-1001-F	
A19R51	0757-0420	3	1	RESISTOR 750 1% .125W F TC=0+100	24546	C4-1/8-T0-751-F	
A19R52	0757-0438	3		RESISTOR 5.11K 1% .125W F TC=0+100	24546	C4-1/8-T0-5111-F	
A19R53	0757-0401	0		RESISTOR 100 1% .125W F TC=0+100	24546	C4-1/8-T0-101-F	
A19R54 - 56	0698-3442	9		RESISTOR 237 1% .125W F TC=0+100	24546	C4-1/8-T0-237R-F	
A19R57	0757-0394	0		RESISTOR 51.1 1% .125W F TC=0+100	24546	C4-1/8-T0-51R1-F	
A19R58	0698-3442	9	RESISTOR 237 1% .125W F TC=0+100	24546	C4-1/8-T0-237R-F		
A19R59	0757-0438	3	RESISTOR 5.11K 1% .125W F TC=0+100	24546	C4-1/8-T0-5111-F		
A19R60	0757-0276	7	RESISTOR 61.9 1% .125W F TC=0+100	24546	C4-1/8-T0-6192-F		
A19R61	0757-0438	3	1	RESISTOR 5.11K 1% .125W F TC=0+100	24546	C4-1/8-T0-5111-F	
A19R62	0698-3442	9		RESISTOR 237 1% .125W F TC=0+100	24546	C4-1/8-T0-237R-F	
A19R63 - R67	0757-0280	3		RESISTOR 1K 1% .125W F TC=0+100	24546	C4-1/8-T0-1001-F	
A19R68	0698-3442	9		RESISTOR 237 1% .125W F TC=0+100	24546	C4-1/8-T0-237R-F	
A19R69	2100-3351	6		RESISTOR-TRMR 500 10% C SIDE-ADJ 1-TRN	28480	2100-3351	
A19R70	0757-0346	2		RESISTOR 10 1% .125W F TC=0+100	24546	C4-1/8-T0-10R0-F	
A19R71	0698-3151	7		RESISTOR 2.87K 1% .125W F TC=0+100	24546	C4-1/8-T0-2871-F	
A19R72 - R73	0698-7205	0		RESISTOR 51.1 1% .05W F TC=0+100	24546	C3-1/8-T0-51R1-F	
A19TP1 - TP15	0360-1682	0		15	TERMINAL-STUD SGL-TUR PRESS-MTG	28480	0360-1682
A19U1	1820-1179	7		1	IC GATE ECL DUAL 3-INP (ALTERNATE P/N 1820-0735)	28480	C164C-0144
A19U2	5088-7009	4	VCO STARTABLE		28480	5088-7009	
A19U3	1820-1225	4	IC FF ECL D-M/S DUAL		04713	MC10231P	
A19U4	1820-0817	8	IC FF ECL D-M/S DUAL		04713	MC10131P	
A19U5	1820-1632	7	IC CNTR ECL BIN ASYNCHRO POS-EDGE-TRIG		04713	MC10178P	
A19U6	1820-0806	5	IC GATE ECL OR-NOR DUAL 4-5-INP		04713	MC10109P	
A19U7	5088-7080	5	IC FF ECL D-M/S POS-EDGE-TRIG		28480	5088-7080	
A19U8	1820-1225	4	IC FF ECL D-M/S DUAL		04713	MC10231P	
A19U9	1820-1482	5	IC GATE ECL NOR DUAL 3-INP		04713	MC10211P	
A19U10	1820-0802	1	IC GATE ECL NOR QUAD 2-INP		04713	MC10102P	
A19U11	1820-0493	6	IC OP AMP GP 8-DIP-P PKG		27014	LM307N	
A19U12	1820-1344	8	IC PL LOOP 14-DIP-C PKG		04713	MC12040L	
A19U13	1820-1225	4	IC FF ECL D-M/S DUAL		04713	MC10231P	
A19W1	8159-0005	0	1		RESISTOR-ZERO OHMS 22 AWG LEAD DIA	28480	8159-0005
A19XU1, 1-16	1200-0475	0	32		CONNECTOR-SGL CONT SKT .017-IN-BSC-SZ	28480	1200-0475

See introduction to this section for ordering information
*Indicates factory selected value

Table 6-2. Replaceable Parts (Continued)

Reference Designation	HP Part Number	C D	Qty	Description	Mfr Code	Mfr Part Number
A21	05370-60124	8	1	BOARD ASSY- 200MHZ MULTIPLIER (SERIES 2740)	28480	05370-60124
A21C1	0140-0209	9	4	CAPACITOR-FXD 5PF +10% 500VDC MICA	72136	DM15C050K0500WV1CR
A21C2	0121-0036	0	6	CAPACITOR-V TRMR-CER 5.5-18PF 350V	52763	304324 5.5/18PF NPO
A21C3	0160-4040	9	9	CAPACITOR-FXD 1000PF +20% 100VDC CER	28480	0160-4040
A21C4	0160-2055	9	10	CAPACITOR-FXD .01UF +80-20% 100VDC CER	28480	0160-2055
A21C5	0160-2055	9		CAPACITOR-FXD .01UF +80-20% 100VDC CER	28480	0160-2055
A21C6	0121-0036	0		CAPACITOR-V TRMR-CER 5.5-18PF 350V	52763	304324 5.5/18PF NPO
A21C7	0160-2238	0	4	CAPACITOR-FXD 1.5PF +.25PF 500VDC CER	28480	0160-2238
A21C8	0160-2247	1	2	CAPACITOR-FXD 3.9PF +.25PF 500VDC CER	28480	0160-2247
A21C9	0160-4040	6		CAPACITOR-FXD 1000PF +20% 100VDC CER	28480	0160-4040
A21C10	0121-0036	0		CAPACITOR-V TRMR-CER 5.5-18PF 350V	52763	304324 5.5/18PF NPO
A21C11	0160-2055	9		CAPACITOR-FXD .01UF +80-20% 100VDC CER	28480	0160-2055
A21C12	0121-0036	0		CAPACITOR-V TRMR-CER 5.5-18PF 350V	52763	304324 5.5/18PF NPO
A21C13	0160-4040	6		CAPACITOR-FXD 1000PF +20% 100VDC CER	28480	0160-4040
A21C14	0160-2055	9		CAPACITOR-FXD .01UF +80-20% 100VDC CER	28480	0160-2055
A21C15	0160-2238	0		CAPACITOR-FXD 1.5PF +.25PF 500VDC CER	28480	0160-2238
A21C16	0160-2247	1		CAPACITOR-FXD 3.9PF +.25PF 500VDC CER	28480	0160-2247
A21C17	0180-0491	5	3	CAPACITOR-FXD 10UF+20% 25VDC TA	28480	0180-0491
A21C18	0121-0036	0		CAPACITOR-V TRMR-CER 5.5-18PF 350V	52763	304324 5.5/18PF NPO
A21C19	0160-2055	9		CAPACITOR-FXD .01UF +80-20% 100VDC CER	28480	0160-2055
A21C20	0121-0036	0		CAPACITOR-V TRMR-CER 5.5-18PF 350V	52763	304324 5.5/18PF NPO
A21C21	0140-0209	9		CAPACITOR-FXD 5PF +10% 500VDC MICA	72136	DM15C050K0500WV1CR
A21C22	0121-0165	6	7	CAPACITOR-V TRMR-CER 7-25PF 350V PC-MTG	52763	304324 7/25PF N300
A21C23	0160-4040	6		CAPACITOR-FXD 1000PF +20% 100VDC CER	28480	0160-4040
A21C24	0160-2055	9		CAPACITOR-FXD .01UF +80-20% 100VDC CER	28480	0160-2055
A21C25	0160-2055	9		CAPACITOR-FXD .01UF +80-20% 100VDC CER	28480	0160-2055
A21C26	0140-0201	1	2	CAPACITOR-FXD 12PF +5% 500VDC MICA	72136	DM15C120J0500WV1CR
A21C27	0140-0209	9		CAPACITOR-FXD 5PF +10% 500VDC MICA	72136	DM15C050K0500WV1CR
A21C28	0121-0165	6		CAPACITOR-V TRMR-CER 7-25PF 350V PC-MTG	52763	304324 7/25PF N300
A21C29	0160-4040	6		CAPACITOR-FXD 1000PF +20% 100VDC CER	28480	0160-4040
A21C30	0160-4040	6		CAPACITOR-FXD 1000PF +20% 100VDC CER	28480	0160-4040
A21C31	0140-0201	1		CAPACITOR-FXD 12PF +5% 500VDC MICA	72136	DM15C120J0500WV1CR
A21C32	0140-0209	9		CAPACITOR-FXD 5PF +10% 500VDC MICA	72136	DM15C050K0500WV1CR
A21C33	0121-0165	6		CAPACITOR-V TRMR-CER 7-25PF 350V PC-MTG	52763	304324 7/25PF N300
A21C34	0160-2055	9		CAPACITOR-FXD .01UF +80-20% 100VDC CER	28480	0160-2055
A21C35	0180-0491	5		CAPACITOR-FXD 10UF+20% 25VDC TA	28480	0180-0491
A21C36	0140-0145	2	4	CAPACITOR-FXD 22PF +5% 500VDC MICA	72136	DM15C220J0500WV1CR
A21C37	0150-0059	8	2	CAPACITOR-FXD 3.3PF +.25PF 500VDC CER	28480	0150-0059
A21C38	0160-2055	9		CAPACITOR-FXD .01UF +80-20% 100VDC CER	28480	0160-2055
A21C39	0180-0491	5		CAPACITOR-FXD 10UF+20% 25VDC TA	28480	0180-0491
A21C40	0160-4040	6		CAPACITOR-FXD 1000PF +20% 100VDC CER	28480	0160-4040
A21C41	0160-4040	6		CAPACITOR-FXD 1000PF +20% 100VDC CER	28480	0160-4040
A21C42	0150-0059	8		CAPACITOR-FXD 3.3PF +.25PF 500VDC CER	28480	0150-0059
A21C43 - C45	0160-3879	7	3	CAPACITOR-FXD .01UF +20% 100VDC CER	28480	0160-3879
A21C46	0121-0165	6		CAPACITOR-V TRMR-CER 7-25PF 350V PC-MTG	52763	304324 7/25PF N300
A21C47	0140-0145	2		CAPACITOR-FXD 22PF +5% 500VDC MICA	72136	DM15C220J0500WV1CR
A21C48	0160-2238	0		CAPACITOR-FXD 1.5PF +.25PF 500VDC CER	28480	0160-2238
A21C49	0160-2238	0		CAPACITOR-FXD 1.5PF +.25PF 500VDC CER	28480	0160-2238
A21C50	0160-4040	6		CAPACITOR-FXD 1000PF +20% 100VDC CER	28480	0160-4040
A21C51	0121-0165	6		CAPACITOR-V TRMR-CER 7-25PF 350V PC-MTG	52763	304324 7/25PF N300
A21C52	0121-0165	6		CAPACITOR-V TRMR-CER 7-25PF 350V PC-MTG	52763	304324 7/25PF N300
A21C53	0140-0145	2		CAPACITOR-FXD 22PF +5% 500VDC MICA	72136	DM15C220J0500WV1CR
A21C54	0121-0165	6		CAPACITOR-V TRMR-CER 7-25PF 350V PC-MTG	52763	304324 7/25PF N300
A21C55	0140-0145	2		CAPACITOR-FXD 22PF +5% 500VDC MICA	72136	DM15C220J0500WV1CR
A21C56	0180-3046	0	1	CAPACITOR-FXD 250PF +1% 100VDC MICA	28480	0160-3046
A21CR1 - CR2	1901-0040	1	2	DIODE-SWITCHING 30V 50MA 2NS DO-35	28480	1901-0040
A21L1 - L6	05370-60127	1	6	COIL AY-200 MHZ	28480	05370-60127
A21L7	9140-0095	0	6	INDUCTOR 270NH 10% .155DX.375LG Q=45	28480	9140-0095
A21L8	9100-1788	6	3	CORE-FERRITE CHOKE-WIDEBAND; IMP:>680	28480	9100-1788
A21L9	9140-0095	0		INDUCTOR 270NH 10% .155DX.375LG Q=45	28480	9140-0095
A21L10	9100-1788	6		CORE-FERRITE CHOKE-WIDEBAND; IMP:>680	28480	9100-1788

See introduction to this section for ordering information
*Indicates factory selected value

Table 6-2. Replaceable Parts (Continued)

Reference Designation	HP Part Number	C D	Qty	Description	Mfr Code	Mfr Part Number
A21L11	9100-1788	6		CORE-FERRITE CHOKE-WIDEBAND; IMP:>680	28480	9100-1788
A21L12 - L15	9140-0095	0		INDUCTOR 270NH 10% .155DX.375LG Q=45	28480	9140-0095
A21L16	9100-0348	2	1	INDUCTOR RF-CH-MLD 1UH 1% .166DX.385LG	28480	9100-0348
A21MP1 - MP2	0403-0189	2	2	EXTR-PC BD BLK POLYC .062-BD-THKNS	28480	0403-0189
A21MP3 - MP4	1480-0116	8	2	PIN-GRV .062-IN-DIA .25-IN-LG STL	28480	1480-0116
A21Q1 - Q8	1854-0092	2	8	TRANSISTOR NPN SI PD=200MW FT=600MHZ	28480	1854-0092
A21R1	0757-0269	8	9	RESISTOR 270 1% .125W F TC=0+100	24546	C4-1/8-T0-271-F
A21R2	0757-0401	0	3	RESISTOR 100 1% .125W F TC=0+100	24546	C4-1/8-T0-101-F
A21R3	0757-0269	8		RESISTOR 270 1% .125W F TC=0+100	24546	C4-1/8-T0-271-F
A21R4	0757-0394	0	1	RESISTOR 51.1 1% .125W F TC=0+100	24546	C4-1/8-T0-51R1-F
A21R5	0757-0269	8		RESISTOR 270 1% .125W F TC=0+100	24546	C4-1/8-T0-271-F
A21R6	0757-0269	8		RESISTOR 270 1% .125W F TC=0+100	24546	C4-1/8-T0-271-F
A21R7	0757-0269	8		RESISTOR 270 1% .125W F TC=0+100	24546	C4-1/8-T0-271-F
A21R8	0757-0269	8		RESISTOR 270 1% .125W F TC=0+100	24546	C4-1/8-T0-271-F
A21R9	0757-0405	4	1	RESISTOR 162 1% .125W F TC=0+100	24546	C4-1/8-T0-162R-F
A21R10	0757-0269	8		RESISTOR 270 1% .125W F TC=0+100	24546	C4-1/8-T0-271-F
A21R11	0757-0433	8	1	RESISTOR 3.32K 1% .125W F TC=0+100	24546	C4-1/8-T0-3321-F
A21R12	0757-0269	8		RESISTOR 270 1% .125W F TC=0+100	24546	C4-1/8-T0-271-F
A21R13	0757-0444	1	2	RESISTOR 12.1K 1% .125W F TC=0+100	24546	C4-1/8-T0-1212-F
A21R14	0757-0414	5	1	RESISTOR 432 1% .125W F TC=0+100	24546	C4-1/8-T0-432R-F
A21R15	0757-0269	8		RESISTOR 270 1% .125W F TC=0+100	24546	C4-1/8-T0-271-F
A21R16	0757-0401	0		RESISTOR 100 1% .125W F TC=0+100	24546	C4-1/8-T0-101-F
A21R17	0757-0441	8	3	RESISTOR 8.25K 1% .125W F TC=0+100	24546	C4-1/8-T0-8251-F
A21R18	0757-0441	8		RESISTOR 8.25K 1% .125W F TC=0+100	24546	C4-1/8-T0-8251-F
A21R19	0757-0442	9	12	RESISTOR 10K 1% .125W F TC=0+100	24546	C4-1/8-T0-1002-F
A21R20	0757-0346	2	3	RESISTOR 10 1% .125W F TC=0+100	24546	C4-1/8-T0-10R0-F
A21R21	0757-0415	6	1	RESISTOR 475 1% .125W F TC=0+100	24546	C4-1/8-T0-475R-F
A21R22	0757-0290	5	1	RESISTOR 5K 1% .125W F TC=0+100	24546	C4-1/8-T0-5001-F
A21R23	0757-0442	9		RESISTOR 10K 1% .125W F TC=0+100	24546	C4-1/8-T0-1002-F
A21R24	0757-0439	4	1	RESISTOR 6.81K 1% .125W F TC=0+100	24546	C4-1/8-T0-6811-F
A21R25	0757-0444	1		RESISTOR 12.1K 1% .125W F TC=0+100	24546	C4-1/8-T0-1212-F
A21R26	0757-1094	8	1	RESISTOR 3K 1% .125W F TC=0+100	24546	C4-1/8-T0-3001-F
A21R27	0757-0441	8		RESISTOR 8.25K 1% .125W F TC=0+100	24546	C4-1/8-T0-8251-F
A21R28	0757-0199	3	2	RESISTOR 21.5K 1% .125W F TC=0+100	24546	C4-1/8-T0-2152-F
A21R29 - R30	0757-0440	7	2	RESISTOR 7.5K 1% .125W F TC=0+100	24546	C4-1/8-T0-7501-F
A21R31	0757-0199	3		RESISTOR 21.5K 1% .125W F TC=0+100	24546	C4-1/8-T0-2152-F
A21R32	0757-0430	5	2	RESISTOR 2.21K 1% .125W F TC=0+100	24546	C4-1/8-T0-2211-F
A21R33	0757-0442	9		RESISTOR 10K 1% .125W F TC=0+100	24546	C4-1/8-T0-1002-F
A21R34	0757-0442	9		RESISTOR 10K 1% .125W F TC=0+100	24546	C4-1/8-T0-1002-F
A21R35	0757-0430	5		RESISTOR 2.21K 1% .125W F TC=0+100	24546	C4-1/8-T0-2211-F
A21R36 - R43	0757-0442	9		RESISTOR 10K 1% .125W F TC=0+100	24546	C4-1/8-T0-1002-F
A21R44	0757-0401	0		RESISTOR 100 1% .125W F TC=0+100	24546	C4-1/8-T0-101-F
A21R45	0757-0346	2	2	RESISTOR 10 1% .125W F TC=0+100	24546	C4-1/8-T0-10R0-F
A21R46	0757-0346	2		RESISTOR 10 1% .125W F TC=0+100	24546	C4-1/8-T0-10R0-F
A21TP1 - TP5	0360-1682	0	5	TERMINAL-STUD SGL-TUR PRESS-MTG	28480	0360-1682
A21U1	1820-0920	4	1	IC RCVR ECL LINE RCVR QUAD 2-INP	04713	MC1692L
A21U2	1820-1224	3	1	IC RCVR ECL LINE RCVR TPL 2-INP	04713	MC10216P
A21U3	1826-0138	8	1	IC COMPARATOR GP QUAD 14-DIP-P PKG	01295	LM339N
A21W1, W2	8159-0005	0	2	A21 MISCELLANEOUS RESISTOR-ZERO OHMS 22 AWG LEAD DIA	28480	8159-0005

See introduction to this section for ordering information
*Indicates factory selected value

Table 6-2. Replaceable Parts (Continued)

Reference Designation	HP Part Number	C D	Qty	Description	Mfr Code	Mfr Part Number
A22	05370-60122	6	1	BOARD ASSEMBLY ARMING (SERIES 2213)	28480	05370-60122
A22C1 - C28	0160-3879	7	37	CAPACITOR-FXD .01UF ±20% 100VDC CER	28480	0160-3879
A22C29	0160-4040	6	1	CAPACITOR-FXD 1000PF ±20% 100VDC CER	28480	0160-4040
A22C30	0160-3879	7		CAPACITOR-FXD .01UF ±20% 100VDC CER	28480	0160-3879
A22C31	0180-0230	0	1	CAPACITOR-FXD 1UF±20% 50VDC TA	56289	150D105X0050A2
A22C32	0160-4389	6	1	CAPACITOR-FXD 100PF -5 +5COG	28480	0160-4389
A22C33 - R36	0160-3879	7		CAPACITOR-FXD .01UF ±20% 100VDC CER	28480	0160-3879
A22C37 - R38	0160-3873	1	2	CAPACITOR-FXD 4.7PF ±.5PF 200VDC CER	28480	0160-3873
A22C39 - C40				NOT ASSIGNED		
A22C41 - C44	0160-3879	7		CAPACITOR-FXD .01UF ±20% 100VDC CER	28480	0160-3879
A22CR1 - CR4	1901-0050	3	4	DIODE-SWITCHING 80V 200MA 2NS DO-35	28480	1901-0050
A22CR5	1902-0943	5	2	DIODE-ZNR 2.4V 5% DO=35 PD=.4W TC=-.037	28480	1902-0943
A22CR6 - CR7	1901-0376	6	2	DIODE-GEN PRP 35V 50MA DO-35	28480	1901-0376
A22CR8	1902-0943	5		DIODE-ZNR 2.4V 5% DO=35 PD=.4W TC=-.037	28480	1902-0943
A22DL1A/B	05370-80001	2	1	DELAY LINE AY-3	28480	05370-80001
A22J1	1200-0614	9	1	SOCKET-RLY 18-CONT DIP-SLDR	28480	1200-0614
A22J2	1251-2026	8	1	CONNECTOR-PC EDGE 18-CONT/ROW 2-ROWS	28480	1251-2026
A22J3	1200-0482	9	1	SOCKET-IC 16-CONT DIP-SLDR	28480	1200-0482
A22J4 - J8	1250-0835	1	5	CONNECTOR-RF SMC M PC 50-OHM	28480	1250-0835
A22L1 - L6	9100-1170	4	6	INDUCTOR 1.2UH ±20% .198D	28480	9100-1170
A22MP1 - MP2	2110-0269	0	2	FUSEHOLDER-CLIP TYPE.25D-FUSE	28480	2110-0269
A22Q1 - Q4	1854-0345	8	10	TRANSISTOR NPN 2N5179 SI TO-72 PD=200MW	04713	2N5179
A22Q5	1854-0246	8	2	TRANSISTOR NPN SI PD=350MW FT=250MHZ	04713	SPS 233
A22Q6	1854-0246	8		TRANSISTOR NPN SI PD=350MW FT=250MHZ	04713	SPS 233
A22Q7 - Q12	1854-0345	8		TRANSISTOR NPN 2N5179 SI TO-72 PD=200MW	04713	2N5179
A22Q13	1855-0334	7	1	TRANSISTOR-DUAL N-CHAN D-MODE SI	17856	DN377
A22R1	1810-0204	6	4	NETWORK-RES 8-SIP 1.0K OHM X 7	28480	1810-0204
A22R2	1810-0203	5	3	NETWORK-RES 8-SIP 470.0 OHM X 7	28480	1810-0203
A22R3	0757-0421	4	13	RESISTOR 825 1% .125W F TC=0±100	24546	C4-1/8-T0-825R-F
A22R4	0757-0421	4		RESISTOR 825 1% .125W F TC=0±100	24546	C4-1/8-T0-825R-F
A22R5	1810-0203	5		NETWORK-RES 8-SIP 470.0 OHM X 7	28480	1810-0080
A22R6 - R13	0757-0421	4		RESISTOR 825 1% .125W F TC=0±100	24546	C4-1/8-T0-825R-F
A22R14 - R15	1810-0204	6		NETWORK-RES 8-SIP 1.0K OHM X 7	28480	1810-0204
A22R16	0698-3132	4	7	RESISTOR 261 1% .125W F TC=0±100	24546	C4-1/8-T0-2610-F
A22R17	0698-7205	0	1	RESISTOR 51.1 1% .05W F TC=0±100	24546	C3-1/8-T0-51R1-F
A22R18	0757-0280	3	7	RESISTOR 1K 1% .125W F TC=0±100	24546	C4-1/8-T0-1001-F
A22R19	0698-3150	6	1	RESISTOR 2.37K 1% .125W F TC=0±100	24546	C4-1/8-T0-2371-F
A22R20	0698-3438	3	2	RESISTOR 147 1% .125W F TC=0±100	24546	C4-1/8-T0-147R-F
A22R21	0757-0416	7	2	RESISTOR 511 1% .125W F TC=0±100	24546	C4-1/8-T0-511R-F
A22R22	0757-0421	4		RESISTOR 825 1% .125W F TC=0±100	24546	C4-1/8-T0-825R-F
A22R23	1810-0204	6		NETWORK-RES 8-SIP 1.0K OHM X 7	28480	1810-0204
A22R24	0698-3438	3		RESISTOR 147 1% .125W F TC=0±100	24546	C4-1/8-T0-147R-F
A22R25	0757-0200	7	2	RESISTOR 5.62K 1% .125W F TC=0±100	24546	C4-1/8-T0-5621-F
A22R26	0757-0280	3		RESISTOR 1K 1% .125W F TC=0±100	24546	C4-1/8-T0-1001-F
A22R27	0757-0200	7		RESISTOR 5.62K 1% .125W F TC=0±100	24546	C4-1/8-T0-5621-F
A22R28	0757-0401	0	6	RESISTOR 100 1% .125W F TC=0±100	24546	C4-1/8-T0-101-F
A22R29	0698-3445	2	6	RESISTOR 348 1% .125W F TC=0±100	24546	C4-1/8-T0-348R-F
A22R30	0757-0416	7		RESISTOR 511 1% .125W F TC=0±100	24546	C4-1/8-T0-511R-F
A22R31	0698-3445	2		RESISTOR 348 1% .125W F TC=0±100	24546	C4-1/8-T0-348R-F
A22R32	0757-0280	3		RESISTOR 1K 1% .125W F TC=0±100	24546	C4-1/8-T0-1001-F
A22R33	0698-0085	0	1	RESISTOR 2.61K 1% .125W F TC=0±100	24546	C4-1/8-T0-2611-F
A22R34	0757-0276	7	3	RESISTOR 61.9 1% .125W F TC=0±100	24546	C4-1/8-T0-6192-F
A22R35	0757-0401	0		RESISTOR 100 1% .125W F TC=0±100	24546	CR-1/8-T0-101-F
A22R36	0757-0276	7		RESISTOR 61.9 1% .125W F TC=0±100	24546	C4-1/8-T0-6192-F
A22R37	0698-0082	7	5	RESISTOR 464 1% .125W F TC=0±100	24546	C4-1/8-T0-4640-F
A22R38	0757-0280	3		RESISTOR 1K 1% .125W F TC=0±100	24546	C4-1/8-T0-1001-F
A22R39	0698-3155	1	2	RESISTOR 4.64K 1% .125W F TC=0±100	24546	C4-1/8-T0-4641-F
A22R40	0698-0082	7		RESISTOR 464 1% .125W F TC=0±100	24546	C4-1/8-T0-4640-F

See introduction to this section for ordering information
*Indicates factory selected value

Table 6-2. Replaceable Parts (Continued)

Reference Designation	HP Part Number	C D	Qty	Description	Mfr Code	Mfr Part Number
A22R41	0757-0280	3		RESISTOR 1K 1% .125W F TC=0±100	24546	C4-1/8-T0-1001-F
A22R42	0757-0421	4		RESISTOR 825 1% .125W F TC=0±100	24546	C4-1/8-T0-825R-F
A22R43	1810-0370	7	1	RESISTOR-NETWORK 8-SIP 220 OHM X 7	28480	1810-0370
A22R44	0757-0394	0	11	RESISTOR 51.1 1% .125W F TC=0±100	24546	C4-1/8-T0-51R1-F
A22R45	0757-0394	0		RESISTOR 51.1 1% .125W F TC=0±100	24546	C4-1/8-T0-51R1-F
A22R46				NOT ASSIGNED		
A22R47	0757-0276	7	1	RESISTOR 61.9 1% .05W F TC=0±100	24546	C4-1/8-T0-6192-F
A22R48	0698-7205	0	33	RESISTOR 51.1 1% .05W F TC=0±100	24546	C3-1/8-T0-51R1-F
A22R49	0698-7205	0		RESISTOR 51.1 1% .05W F TC=0±100	24546	C3-1/8-T0-51R1-F
A22R50	0757-0394	0		RESISTOR 51.1 1% .125W F TC=0±100	24546	C4-1/8-T0-51R1-F ^
A22R51	0698-3132	4		RESISTOR 261 1% .125W F TC=0±100	24546	C4-1/8-T0-2610-F
A22R52	0757-0346	2	1	RESISTOR 10 1% .125W F TC=0±100	24546	C4-1/8-T0-10R0-F
A22R53	0698-7205	0		RESISTOR 51.1 1% .05W F TC=0±100	24546	C3-1/8-T0-51R1-F
A22R54	0757-0401	0	3	RESISTOR 100 1% .125W F TC=0±100	24546	C4-1/8-T0-101-F
A22R55	0698-7205	0		RESISTOR 51.1 1% .05W F TC=0±100	24546	C3-1/8-T0-51R1-F
A22R56	0698-3445	2		RESISTOR 348 1% .125W F TC=0±100	24546	C4-1/8-T0-348R-F
A22R57	0698-7205	0		RESISTOR 51.1 1% .05W F TC=0±100	24546	C3-1/8-T0-51R1-F
A22R58	0698-0082	7		RESISTOR 464 1% .125W F TC=0±100	24546	C4-1/8-T0-4640-F
A22R59	0698-7201	6	4	RESISTOR 34.8 1% .05W F TC=0±100	24546	C3-1/8-T0-34R8-F
A22R60	0698-3132	4		RESISTOR 261 1% .125W F TC=0±100	24546	C4-1/8-T0-2610-F
A22R61	0698-7207	2	1	RESISTOR 61.9 1% .05W F TC=0±100	12482	C3-1/8-T0-61R9-F
A22R62	0698-7205	0		RESISTOR 51.1 1% .05W F TC=0±100	24546	C3-1/8-T0-51R1-F
A22R63	2100-3350	5	2	RESISTOR-TRMR 200 10% C SIDE-ADJ 1-TRN	28480	2100-3350
A22R64	0698-7222	1	2	RESISTOR 261 1% .05W F TC=0±100	24546	C3-1/8-T0-261R-F
A22R65	2100-3350	5		RESISTOR-TRMR 200 10% C SIDE-ADJ 1-TRN	28480	2100-3350
A22R66	0757-0401	0		RESISTOR 100 1% .125W F TC=0±100	24546	CR-1/8-T0-101-F
A22R67	0698-3445	2		RESISTOR 348 1% .125W F TC=0±100	24546	C4-1/8-T0-348R-F
A22R68	0698-7216	3	2	RESISTOR 147 1% .05W F TC=0±100	24546	C3-1/8-T0-147R-F
A22R69	0698-3132	4		RESISTOR 261 1% .125W F TC=0±100	24546	C4-1/8-T0-2610-F
A22R70	0757-0394	0		RESISTOR 51.1 1% .125W F TC=0±100	24546	C4-1/8-T0-51R1-F
A22R71	0757-0438	3	1	RESISTOR 5.11K 1% .125W F TC=0±100	2M627	CRB14 OR CRB25
A22R72	0698-7205	0		RESISTOR 51.1 1% .05W F TC=0±100	24546	C3-1/8-T0-51R1-F
A22R73	0698-0082	7		RESISTOR 464 1% .125W F TC=0±100	24546	C4-1/8-T0-4640-F
A22R74	0757-0401	0		RESISTOR 100 1% .125W F TC=0±100	24546	C4-1/8-T0-101-F
A22R75	0757-0401	0		RESISTOR 100 1% .125W F TC=0±100	24546	C4-1/8-T0-101-F
A22R76				NOT ASSIGNED		
A22R77	0698-3132	4		RESISTOR 261 1% .125W F TC=0±100	24546	C4-1/8-T0-2610-F
A22R78	0757-0280	3		RESISTOR 1K 1% .125W F TC=0±100	24546	C4-1/8-T0-1001-F
A22R79	0698-3445	2		RESISTOR 348 1% .125W F TC=0±100	24546	C4-1/8-T0-348R-F
A22R80	0757-0394	0		RESISTOR 51.1 1% .125W F TC=0±100	24546	C4-1/8-T0-51R1-F
A22R81	0698-3446	3	2	RESISTOR 383 1% .125W F TC=0±100	24546	C4-1/8-T0-383R-F
A22R82	0698-7201	6	3	RESISTOR 34.8 1% .05W F TC=0±100	24546	C3-1/8-T0-34R8-F
A22R83	0698-7201	6		RESISTOR 34.8 1% .05W F TC=0±100	24546	C3-1/8-T0-34R8-F
A22R84	0698-7201	6		RESISTOR 34.8 1% .05W F TC=0±100	24546	C3-1/8-T0-34R8-F
A22R85	1810-0203	5		NETWORK-RES 8-SIP 470.0 OHM X 7	28480	1810-0203
A22R86	0698-3446	3		RESISTOR 383 1% .125W F TC=0±100	24546	C4-1/8-T0-383R-F
A22R87	0757-0394	0		RESISTOR 51.1 1% .125W F TC=0±100	24546	C4-1/8-T0-51R1-F
A22R88	0757-0394	0		RESISTOR 51.1 1% .125W F TC=0±100	24546	C4-1/8-T0-51R1-F
A22R89	0698-3132	4		RESISTOR 261 1% .125W F TC=0±100	24546	C4-1/8-T0-2610-F
A22R90	0757-0280	3		RESISTOR 1K 1% .125W F TC=0±100	24546	C4-1/8-T0-1001-F
A22R91	0757-0421	4		RESISTOR 825 1% .125W F TC=0±100	24546	C4-1/8-T0-825R-F
A22R92	0698-3441	8	6	RESISTOR 215 1% .125W F TC=0±100	24546	C4-1/8-T0-215R-F
A22R93	0698-3441	8		RESISTOR 215 1% .125W F TC=0±100	24546	C4-1/8-T0-215R-F
A22R94	0698-0082	7		RESISTOR 464 1% .125W F TC=0±100	24546	C4-1/8-T0-4640-F
A22R95 R98	0698-3441	8		RESISTOR 215 1% .125W F TC=0±100	24546	C4-1/8-T0-215R-F
A22R99	0698-7216	3		RESISTOR 147 1% .05W F TC=0±100	24546	C3-1/8-T0-147R-F
A22R100	0698-7222	1		RESISTOR 261 1% .05W F TC=0±100	24546	C3-1/8-T0-261R-F
A22R101	0757-0394	0		RESISTOR 51.1 1% .125W F TC=0±100	24546	C4-1/8-T0-51R1-F
A22R102	0757-0394	0		RESISTOR 51.1 1% .125W F TC=0±100	24546	C4-1/8-T0-51R1-F
A22R103	0698-3132	4		RESISTOR 261 1% .125W F TC=0±100	24546	C4-1/8-T0-2610-F
A22R104	0698-3154	0	1	RESISTOR 4.22K 1% .125W F TC=0±100	12482	CT4-1/8-T0-4221F
A22R105	0757-0317	7	1	RESISTOR 1.33K 1% .125W F TC=0±100	24546	C4-1/8-T0-1331-F

See introduction to this section for ordering information
*Indicates factory selected value

Table 6-2. Replaceable Parts (Continued)

Reference Designation	HP Part Number	C D	Qty	Description	Mfr Code	Mfr Part Number
A22R106	0698-3152	8	2	RESISTOR 3.48K 1% .125W F TC=0±100	24546	C4-1/8-T0-3481-F
A22R107	0698-3155	1		RESISTOR 4.64K 1% .125W F TC=0±100	24546	C4-1/8-T0-4641-F
A22R108	0757-0394	0		RESISTOR 51.1 1% .125W F TC=0±100	24546	C4-1/8-T0-51R1-F
A22R109	0698-3152	8	1	RESISTOR 3.48K 1% .125W F	24546	C4-1/8-T0-3481-F
A22R110	0699-0088	5	1	RESISTOR 1.21M 1% .125W F TC=0±100	28480	0699-0088
A22R111	0757-0394	0		RESISTOR 51.1 1% .125W F TC=0±100	24546	C4-1/8-T0-51R1-F
A22R112	0757-0419	0	2	RESISTOR 681 1% .125W F TC=0±100	24546	C4-1/8-T0-681R-F
A22R113	0757-0400	9	2	RESISTOR 90.9 1% .125W F TC=0±100	24546	C4-1/8-T0-90R9-F
A22R114	0757-0419	0		RESISTOR 681 1% .125W F TC=0±100	24546	C4-1/8-T0-681R-F
A22R115	0698-0083	8	1	RESISTOR 1.96K 1% .125W F TC=0±100	24546	C4-1/8-T0-1961-F
A22R116	0698-3445	2		RESISTOR 348 1% .125W F TC=0±100	24546	C4-1/8-T0-348R-F *
A22R117	0757-0400	9		RESISTOR 90.9 1% .125W F TC=0±100	24546	C4-1/8-T0-90R9-F
A22R118	0698-7205	0		RESISTOR 51.1 1% .05W F TC=0±100	24546	C3-1/8-T0-51R1-F
A22R119	0698-3378	0	6	RESISTOR 51 5% .125W CC TC=-270/+540	01121	BB5105
A22R120	0698-7205	0		RESISTOR 51.1 1% .05W F TC=0±100	24546	C3-1/8-T0-51R1-F
A22R121 - R25	0698-3378	0		RESISTOR 51 5% .125W CC TC=-270/+540	01121	BBS105
A22R126	0698-7223	2	2	RESISTOR 287 1% .05W F TC=0±100	24546	C3-1/8-T0-287R-F
A22R127	0698-7223	2		RESISTOR 287 1% .05W F TC=0±100	24546	C3-1/8-T0-287R-F
A22R128	0698-7205	0		RESISTOR 51.1 1% .05W F TC=0±100	24546	C3-1/8-T0-51R1-F
A22R129	0698-7205	0		RESISTOR 51.1 1% .05W F TC=0±100	24546	C3-1/8-T0-51R1-F
A22R130				NOT ASSIGNED		
A22R131	0698-7205	0		RESISTOR 51.1 1% .05W F TC=0±100	24546	C3-1/8-T0-51R1-F
A22R132	0698-7205	0		RESISTOR 51.1 1% .05W F TC=0±100	24546	C3-1/8-T0-51R1-F
A22R133				NOT ASSIGNED		
A22R134 - 153	0698-7205	0		RESISTOR 51.1 1% .05W F TC=0±100	24546	C3-1/8-T0-51R1-F
A22R154	0757-0442	9		RESISTOR 10K 1% .125W F TC=0±100	24546	C4-1/8-T0-1002-F
A22TP1 -TP14	0360-0124	3	14	CONNECTOR-SGL CONT PIN .04-IN-BSC SZ RND	28480	0360-0124 S
A22U1	1820-0802	1	3	IC GATE ECL NOR QUAD 2-INP	04713	MC10102P
A22U2	1820-1225	4	5	IC FF ECL D-M/S DUAL	04713	MC10231P
A22U3	1820-0794	0	1	IC FF ECL D-M/S	04713	MC1670L
A22U4	1820-1225	4		IC FF ECL D-M/S DUAL	04713	MC10231P
A22U5	1820-0802	1		IC GATE ECL NOR QUAD 2-INP	04713	MC10102P
A22U6	1826-0138	8	2	IC COMPARATOR GP QUAD 14-DIP-P PKG	01295	LM339N
A22U7	1826-0138	8		IC COMPARATOR GP QUAD 14-DIP-P PKG	01295	LM339N
A22U8	1820-1225	4		IC FF ECL D-M/S DUAL	04713	MC10231P
A22U9	1820-0805	4	1	IC GATE ECL EXCL-OR/NOR TPL 2-INP	04713	MC10107P
A22U10	1820-0802	1		IC GATE ECL NOR QUAD 2-INP	04713	MC10102P
A22U11	1820-0624	5	3	IC COMPTR ECL A/D DUAL	04713	MC1651L
A22U12	1820-1225	4		IC FF ECL D-M/S DUAL	04713	MC10231P
A22U13	1820-0624	5		IC COMPTR ECL A/D DUAL	04713	MC1651L
A22U14	1820-1225	4		IC FF ECL D-M/S DUAL	04713	MC10231P
A22U15	5088-7081	2	2	IC EECL 3-IN MUX	28480	5088-7081
A22U16	5088-7081	2		IC EECL 3-IN MUX	28480	5088-7081
A22U17	5088-7080	1	3	IC B196D-100 FF	28480	5088-7080
A22U18	1820-1224	3	1	IC RCVR ECL LINE RCVR TPL 2-INP	04713	MC10216P
A22U19	5088-7082	3	7	IC EECL D 3-1 GATE	28480	5088-7082
A22U20	5088-7082	3		IC EECL D 3-1 GATE	28480	5088-7082
A22U21	5088-7080	1		IC B196D-100 FF	28480	5088-7080
A22U22	1820-1399	3	1	IC FF ECL D-TYPE COM CLOCK HEX	04713	MC10176P
A22U23 - 27	5088-7082	3		IC EECL D 3-1 GATE	28480	5088-7082
A22U28	1820-2000	5		IC FF ECL D-M/S POS-EDGE-TRIG	28480	B196D-0100
A22U29	1820-0624	5		IC COMPTR ECL A/D DUAL	04713	MC1651L
A22U30	1820-1052	5	1	IC XLTR ECL ECL-TO-TTL QUAD 2-INP	04713	MC10125L
A22U31	1826-0208	3	1	IC OP AMP GP 8-DIP-P PKG	27014	LM310N
A22 MISCELLANEOUS PARTS						
	3050-0159	0	1	WASHER-NYLON NO. 6 .14-IN-DIA	00000	ORDER BY DESCRIPTION

See introduction to this section for ordering information
*Indicates factory selected value

Table 6-2. Replaceable Parts (Continued)

Reference Designation	HP Part Number	C D	Qty	Description	Mfr Code	Mfr Part Number
A23	05370-60123	7	1	BOARD ASSY, DISPLAY/FRONT PANEL (SERIES 2016)	28480	05370-60123
A23C1	0180-0106	9	1	CAPACITOR-FXD 60UF+20% 6VDC TA	56289	150D606X0006B2
A23C2 - C3	0160-3879	7	2	CAPACITOR-FXD .01UF +20% 100VDC CER	28480	0160-3879
A23DS1 -DS16	1990-0540	3	16	DISPLAY-NUM-SEG 1-CHAR .43-H	28480	5082-7650
A23DS17 -46	1990-0533	4	30	LED-LAMP LUM-INT=15MCD IF=20MA-MAX	28480	5082-4658
A23DS47 -49	1990-0487	7	3	LED-LAMP LUM-INT=1MCD IF=20MA-MAX BVR=5V	28480	5082-4584
A23DS50-66	1990-0670	0	28	LED-LAMP LUM-INT=1MCD IF=20MA-MAX BVR=5V	28480	1990-0670
A23DS67				NOT ASSIGNED		
A23DS68 -70	1990-0670	0		LED-LAMP LUM-INT=1MCD IF=20MA-MAX BVR=5V	28480	1990-0670
A23DS71				NOT ASSIGNED		
A23DS72	1990-0670	0		LED-LAMP LUM-INT=1MCD IF=20MA-MAX BVR=5V	28480	1990-0670
A23DS73 -74				NOT ASSIGNED		
A23DS75 -81	1990-0670	0		LED-LAMP LUM-INT=1MCD IF=20MA-MAX BVR=5V	28480	1990-0670
A23DS82	1990-0486	6	1	LED-LAMP LUM-INT=1MCD IF=20MA-MAX BVR=5V	28480	5082-4684
A23H1 - H4	0624-0270		2	SCREW-TPG 4-40 .25-IN-LG PAN-HD-POZI STL	00000	ORDER BY DESCRIPTION
A23H4 - H8	2190-0014		2	WASHER-LOCK INT T NO. 2 .089 IN I.D.	00000	ORDER BY DESCRIPTION
A23J1 - J4	1200-0482	9	4	SOCKET-IC 16-CONT DIP-SLDR	28480	1200-0482
A23MP1	05341-20037	3	1	BLOCK-ANNUN	28480	05341-20037
A23MP2	05341-40001	3	1	BLOCK-ANNUN	28480	05341-40001
A23MP3	05370-40001	8	1	BLOCK-ANNUN	28480	05370-40001
A23MP4 - MP6	05328-40003	8	3	SPACER-LED LONG	28480	05328-40003
A23MP7	4040-2121		1	STANDOFF- LED	28480	4040-2121
A23R1 - R15	0698-7229	8	15	RESISTOR 511 1% .05W F TC=0+100	24546	C3-1/8-T0-511R-F
A23R16	2100-3849	7	1	RESISTOR-VAR W/SW 470K 20% 10CCW SPST-NO	28480	2100-3849
A23R17	2100-3850	0	1	RESISTOR-VAR W/SW 200 20% LIN SPST-NO	28480	2100-3850
A23R18	0699-0073	8	1	RESISTOR 10M 1% .125W F TC=0+150	28480	0699-0073
A23S1 - S30	5060-9436	7	30	PUSHBUTTON SWITCH P.C. MOUNT	28480	5060-9436
A23S31				NOT ASSIGNED		
A23S32				NOT ASSIGNED		
A23S33	3101-2220	9	1	SWITCH-SL DPDT MINTR .5A 125VAC/DC PC	28480	3101-2220
A23U1	1820-0174	0	1	IC INV TTL HEX	01295	SN7404N
A23U2	1820-0539	1	1	IC BFR TTL NAND QUAD 2-INP	01295	SN7437N
A23XDS1 -16	1200-0474	9	16	SOCKET-IC 14-CONT DIP-SLDR	28480	1200-0474
				A23 MISCELLANEOUS		
	5041-0253	8	10	KEY CAP-1/2	28480	5041-0253
	5041-0310	8	2	KEY CAP-BLANK	28480	5041-0310
	5041-0319	7	18	KEY CAP-LGT PIPE	28480	5041-0319
	05370-00014	9	1	DIFFUSER #1	28480	05370-00014
	05370-00015	0	1	DIFFUSER #2	28480	05370-00015

See introduction to this section for ordering information
*Indicates factory selected value

Table 6-2. Replaceable Parts (Continued)

Reference Designation	HP Part Number	C D	Qty	Description	Mfr Code	Mfr Part Number
CHASSIS PARTS						
A12MP3, 4	1480-0116	8	4	PIN-GROOVE .062-IN-DIA .25-IN-LG STL	28480	1480-0116
A14MP1,2	0403-0189	2	4	EXTRACTOR PC BD BLK POLYC .062-IN-BD	28480	0403-0189
A14MP3, 4	1480-0116	8		PIN-GROOVE .062-IN-DIA .25-IN-LG STL	28480	1480-0116
A24	0960-0443	1	1	LINE MODULE - FILTERED	28480	0960-0443
A24, MP1,2	0403-0189	2		EXTRACTOR PC BD BLK POLYC .062-IN-BD	28480	0403-0189
B1	3160-0209	4	1	FAN-TBAX 32-CFM 105-125V 50/60-HZ	23936	8500D
CB1	3103-0032	1	1	SWITCH-THRM FXD +194F 3A OPN-ON-RISE	28480	3103-0032
C1	0160-3879	7	1	CAPACITOR-FXD .01UF +20% 100VDC CER	28480	0160-3879
CR2 - CR4	1906-0222	1	4	DIODE-FW BRDG 400V 25A	28480	1906-0222
F1(115V)	2110-0083	6	1	FUSE 2.5A 250V NTD 1.25X.25 UL	28480	2110-0083
F1(230V)	2110-0305	5	1	FUSE 1.25A 250V TD 1.25X.25 UL	75915	3131.25
MP1	5062-3704		2	STRAP HANDLE 18 IN.	28480	5062-3704
MP2	5062-3780		1	COVER-SIDE	28480	5062-3780
	05359-00008		1	COVER-SIDE, PERFORATED	28480	05359-00008
MP3	5062-3747		1	COVER-BOTTOM ASSY (METRIC)	28480	5062-3747
MP4	5062-3735		1	COVER-TOP ASSY (METRIC)	28480	5062-3735
MP5	1205-0335	1	1	HEAT SINK TO-3-CS	28480	1205-0335
MP6	5040-6928	6	1	STRIP DIVIDER	28480	5040-6928
MP7	5041-8802		1	TRIM, TOP	28480	5041-8802
MP8	5041-8821		2	FOOT NON-SKID	28480	5041-8821
MP9	5040-7221	2	4	FOOT, REAR	28480	5040-7221
MP10	5041-8819		2	STRAP HANDLE CAP-FRONT (METRIC)	28480	5041-8819
MP11	5041-8820		2	STRAP HANDLE CAP-REAR (METRIC)	28480	5041-8820
MP12	5040-7201	8	2	FOOT (STANDARD)	28480	5040-7201
MP13	05370-80005	6	1	LABEL-ERROR MESS. 1.97-IN-WD 2.65-IN-LG	28480	05370-80005
MP14	1460-1345	5	2	TILT STAND SST	28480	1460-1345
MP15 - MP16				NOT ASSIGNED		
MP17	5021-5837	2	4	CORNER STRUT (METRIC)	28480	5021-5837
MP18	05370-00013	8	1	SUPPORT-MOTHERBOARD CENTER	28480	05370-00013
MP19	05370-00006	9	1	SHIELD-OSCILLATOR	28480	05370-00006
MP20	5021-5804	3	1	FRAME-REAR (METRIC)	28480	5021-5804
MP21	5021-8403	2	1	FRAME-FRONT (METRIC)	28480	5021-8403
MP22	05370-00008	1	2	BRACKET-MOTHERBOARD EDGE	28480	05370-00008
MP23	05370-00011	6	1	BD GUIDE-MOTHERBOARD FRONT	28480	05370-00011
MP24	05370-00002	5	1	PANEL-SUB. FRONT	28480	05370-00002
MP25	05370-00004	7	1	PANEL-REAR	28480	05370-00004
MP26	05370-00005	8	1	CHASSIS-POWER SUPPLY	28480	05370-00005
MP27	05370-00007	0	1	BULKHEAD-BOARD SUPPORT	28480	05370-00007
MP28	05370-00009	2	1	BRACKET-MOTHERBOARD FRONT	28480	05370-00009
MP29	05370-20206	3	1	WINDOW	28480	05370-20206
MP30	05370-00001	4	1	PANEL-DRESS FRONT	28480	05370-00001
MP31	05370-00016	1	2	BRACKET-ANGLE	28480	05370-00016
MP32	05370-00017	2	1	HOLDDOWN-BOARD	28480	05370-00017
MP33	5062-3799		2	HANDLE (METRIC)	28480	5062-3799
MP34	5020-8496		2	HANDLE TRIM	28480	5020-8496
Q1 - Q2	1854-0669	9	2	TRANSISTOR NPN 2N6057 SI TO-3 PD=150W	04713	2N6057
Q3 - Q4	1853-0411	7	2	TRANSISTOR PNP 2N6050 SI DARL TO-3	28480	1853-0411
S1	3101-1720	2	1	SWITCH-PB DPDT 4A 250VAC	28480	3101-1720
T1	9100-3056	5	1	TRANSFORMER-POWER 100/120/220/240V	28480	9100-3056
W1	05370-60401	4	1	CABLE AY-POWER SUPPLY XSTR	28480	05370-60401
W2	05370-60402	5	1	CABLE AY-POWER SWITCH	28480	05370-60402
W3	05370-60403	6	1	CABLE AY-START	28480	05370-60403
W4	05370-60404	7	1	CABLE AY-EXT T IN	28480	05370-60404
W5	05370-60405	8	1	CABLE AY-EXT FR IN	28480	05370-60405

See introduction to this section for ordering information
*Indicates factory selected value

Table 6-2. Replaceable Parts (Continued)

Reference Designation	HP Part Number	C D	Qty	Description	Mfr Code	Mfr Part Number
W6	05370-60406	9	1	CABLE AY-10MHZ OUT	28480	05370-60406
W7	05370-60407	0	1	CABLE AY-10MHZ TIMEBASE	28480	05370-60407
W8	05370-60408	1	1	CABLE AY-REAR PANEL	28480	05370-60408
W9	05370-60409	2	1	CABLE AY-10MHZ AZ	28480	05370-60409
W10	05370-60410	5	1	CABLE AY-EXT T OUT	28480	05370-60410
W11	8120-2463	7	1	CABLE ASSY 26AWG 18-CNDCT	28480	8120-2463
W12 - W17	8120-2462	6	6	CABLE ASSY 26AWG 16-CNDCT	28480	8120-2462
W18	8120-1378	1	1	CABLE ASSY -POWER 18AWG 3-CNDCT JGK-JKT	28480	8120-1378
MISCELLANEOUS						
	0340-0596	1	4	INSULATOR-XSTR THRM-CNDCT	28480	0340-0596
	0340-0833	9	4	INSULATOR-XSTR POLYE	28480	0340-0833
	0362-0265	7	7	CONNECTOR-SGL CONT	28480	0362-0265
	0370-0914	0	1	BEZEL-PB KNOB .490LG .330W .165 HI JADE	28480	0370-0914
	0370-1005	2	4	KNOB-BASE-PTR 3/8 JGK .125-IN-ID	28480	0370-1005
	0380-0008	4	1	SPACER .180 ID .250 OD	28480	0380-0008
	0380-0018	6	2	SPACER .194 ID .250 OD	28480	0380-0018
	0380-0644	4	2	STANDOFF (FOR HP-IB CONNECTOR)	28480	0380-0644
	0510-1148	2	17	RETAINER-PUSH ON KB-TO-SHFT EXT	28480	0510-1148
	0515-0896	5	6	SCREW-MACH M4 X 0.7 10MM-LG (FOR HANDLES_	28480	0515-0896
	0515-1132	4	4	SCREW-MACH M5 X 0.8 10MM-LG (FOR HANDLE CAPS)	28480	0515-1132
	0515-1232	5	4	SCREW-MACH M3.5 X 0.6 8MM LG PAN-HD POZI	00000	ORDER BY DESCRIPTION
	0515-1331	5	8	SCREW-METRIC SPECIALTY M4 X 0.7 THD; 6	28480	0515-1331
	0520-0174	3	2	SCREW-MACH 2-56 .25-IN-LG PAN-HD POZI	00000	ORDER BY DESCRIPTION
	0535-0010	7	2	NUT-HEX DBL-CHAM M7 X 0.75 2.26MM-THK	00000	ORDER BY DESCRIPTION
	0624-0208	4	8	SCREW-TAPPING 6-32 .5-IN-LG PAN-HD POZI	00000	ORDER BY DESCRIPTION
	1400-0017	0	1	CLAMP-CABLE, WHITE NYLON	28480	1400-0017
	1400-0053	4	1	CLAMP, CABLE ACCOMODATES 3-16", BLUE	28480	1400-0053
	1400-0249	0	9	CLAMP, CABLE	28480	1400-0249
	1410-1035	5	2	BUSHING-PNL .136-ID .312-LG 1/4-32-THD	28480	1410-1035
	2190-0017	4	4	WASHER-LK HLCL NO. 8 .168-IN-ID	00000	ORDER BY DESCRIPTION
	2190-0034	5	2	WASHER-LK HLCL NO. 10 .194-IN-ID	00000	ORDER BY DESCRIPTION
	2190-0046	9	8	WASHER-LK HLCL NO. 6 .141-IN-ID	00000	ORDER BY DESCRIPTION
	2190-0047	0	2	WASHER- 82CTSK EXT NO. 6 .142-IN-DIA	00000	ORDER BY DESCRIPTION
	2190-0102	8	4	WASHER INTL T 15/32 IN .472-ID	00000	ORDER BY DESCRIPTION
	2190-0843	4	1	WASHER INTL T NO. 8 .165-IN-ID	00000	ORDER BY DESCRIPTION
	2200-0103	2	1	SCREW-4-40 .25-IN-LG PAN-HD POZI	00000	ORDER BY DESCRIPTION
	2360-0113	2	6	SCREW-MACH 6-32 .25-IN-LG PAN-HD POZI	00000	ORDER BY DESCRIPTION
	2360-0115	4	41	SCREW-MACH 6-32 .312-IN-LG PAN-HD POZI	00000	ORDER BY DESCRIPTION
	2360-0125	6	4	SCREW-MACH 6-32 .75-IN-LG PAN-HD-POZI	00000	ORDER BY DESCRIPTION
	2360-0211	1	2	SCREW-MACH 6-32 .75-IN-LG 82-DEG	00000	ORDER BY DESCRIPTION
	2360-0333	8	3	SCREW-MACH 6-32 .25-IN-LG 100 DEG	00000	ORDER BY DESCRIPTION
	2360-0476	0	8	SCREW-MACH 6-32 .188-IN-LG 100-DEG	00000	ORDER BY DESCRIPTION
	2420-0001	5	1	NUT-HEX W/LKWR 6-32 .109-IN-THK	00000	ORDER BY DESCRIPTION
	2420-0003	7	1	NUT-HEX DBL-CHAM 6-32 .094-THK	00000	ORDER BY DESCRIPTION
	2510-0138	0	4	SCREW-MACH 8-32 3-IN-LG PAN-HD-POZI	00000	ORDER BY DESCRIPTION
	2680-0172	1	4	SCREW-MACH 10-32 .375-IN-LG 100-DEG	00000	ORDER BY DESCRIPTION
	2950-0006	3	2	NUT-HEX DBL-CHAM 1/4-32-THD .094-THK	00000	ORDER BY DESCRIPTION
	2950-0035	8	5	NUT-HEX DBL-CHAM 15/32-THD .078-THK	00000	ORDER BY DESCRIPTION
	2950-0054	1	2	NUT-HEX DBL-CHAM 1/2-28 THD .125-THK	00000	ORDER BY DESCRIPTION
	3050-0001	1	4	WASHER-FLAT MTLN NO. 8 .172-ID	00000	ORDER BY DESCRIPTION
	3050-0066	8	6	WASHER-FLAT MTLN NO. 6 .147-ID	00000	ORDER BY DESCRIPTION
	3050-0159	0	1	WASHER-NYLON NO. 6 .14-IN-ID	00000	ORDER BY DESCRIPTION
	3160-0309	5	1	FINGER GUARD	4N833	12601-43 UL VERSION
	7120-4006	7	1	LABEL-WARNING, FIRE HAZARD	28480	7120-4006
	7121-4706	6	1	LABEL-LINE VOLTAGE	28480	7121-4706
	5040-0170	6	8	GUIDE: PLUG-IN PC BOARD	28480	5040-0170
	5040-6937	5	3	WINDOW CLIP	28480	5040-6937
	5060-9462	9	1	HPIB EXTENDER-ASSY	28480	5060-9462
	5061-1942	6	1	COVER-SIDE ASSY-PERF	28480	5061-1942
	05370-00014	9	1	DIFFUSER #1	28480	05370-00014
	05370-00015	0	1	DIFFUSER #2	28480	05370-00015
	05371-80025	1	1	INSULATOR	28480	05371-80025

See introduction to this section for ordering information
*Indicates factory selected value

Table 6-2. Replaceable Parts (Continued)

Reference Designation	HP Part Number	C D	Qty	Description	Mfr Code	Mfr Part Number
	10811-60111	8	1	QUARTZ OSCILLATOR, 10 MHZ	28480	10811-60111
				OPTIONS		
	5062-3977		1	OPTION 908 - RACK MOUNT FLANGE KIT FOR USE WITH FRONT HANDLES REMOVED	28480	5062-3977
	5062-3977		1	OPTION 913 RACK MOUNT KIT FOR USE WITH FRONT HANDLES	28480	5062-3977

Table 6-3. Manufacturer's Code List

MFR CODE	MANUFACTURER NAME	ADDRESS			ZIP CODE
50545	NEC ELECTRONICS LTD	MOUNTAIN VIEW	CA	US	94043
00000	ANY SATISFACTORY SUPPLIER				
01121	ALLEN-BRADLEY CO INC	EL PASO	TX	US	79935
01295	TEXAS INSTRUMENTS INC	DALLAS	TX	US	75265
03888	KDI PYROFILM CORP	WHIPPANY	NJ	US	07981
04713	MOTOROLA INC SEMI-COND PROD	PHOENIX	AZ	US	85008
07263	FAIRCHILD CORP	MOUNTAIN VIEW	CA	US	94042
18546	VARO SEMICONDUCTOR INC	GARLAND	TX	US	75046
16956	DENNISON MFG CO	FRAMINGHAM	MA	US	01701
17856	SILICONIX INC	SANTA CLARA	CA	US	95054
18324	SIGNETICS CORPORATION	SUNNYVALE	CA	US	94086
23936	PAMOTOR DIV, WILLIAM J PURDY	BURLINGAME	CA	US	94010
24046	TRANSITRON ELECTRONIC CORP	WAKEFIELD	MA	US	01880
24546	CORNING ELECTRONICS	SANTA CLARA	CA	US	95050
27014	NATIONAL SEMICONDUCTOR CORP	SANTA CLARA	CA	US	95052
28480	HEWLETT-PACKARD CO CORPORATE HQ	PALO ALTO	CA	US	94304
3L585	RCA CORPORATION SOLID STATE DIVISION	SOMERVILLE	NJ	US	
30983	MEPCO/ELECTRA CORPORATION	SAN DIEGO	CA	US	92121
31471	AMERICAN MICRO SYSTEMS INC	SANTA CLARA	CA	US	95051
34335	ADVANCED MICRO DEVICES INC	SUNNYVALE	CA	US	94086
4N833	ETRI INC	MONROE	NC	US	28110
51406	MURATA CORPORATION OF AMERICA	MARIETTA	GA	US	30067
52763	STETTNER ELECTRONICS INC	CHATTANOOGA	TN	US	37421
56289	SPRAGUE ELECTRIC CO	NORTH ADAMS	MA	US	01247
72136	ELECTROMOTICE CORPORATION	FLORENCE	SC	US	06226
72982	ERIE TECHNOLOGICAL PRODUCTS INC	ERIE	PA	US	16512
73138	BECKMAN INDUSTRIAL CORPORATION	FULLERTON	CA	US	92632
75915	LITTLEFUSE INC	DES PLAINES	IL	US	60016
91637	DALE ELECTRONICS INC	EL PASO	TX	US	79936
98291	SEAELECTRO CORPORATION	MAMARONECK	NY	US	10544

See introduction to this section for ordering information
*Indicates factory selected value

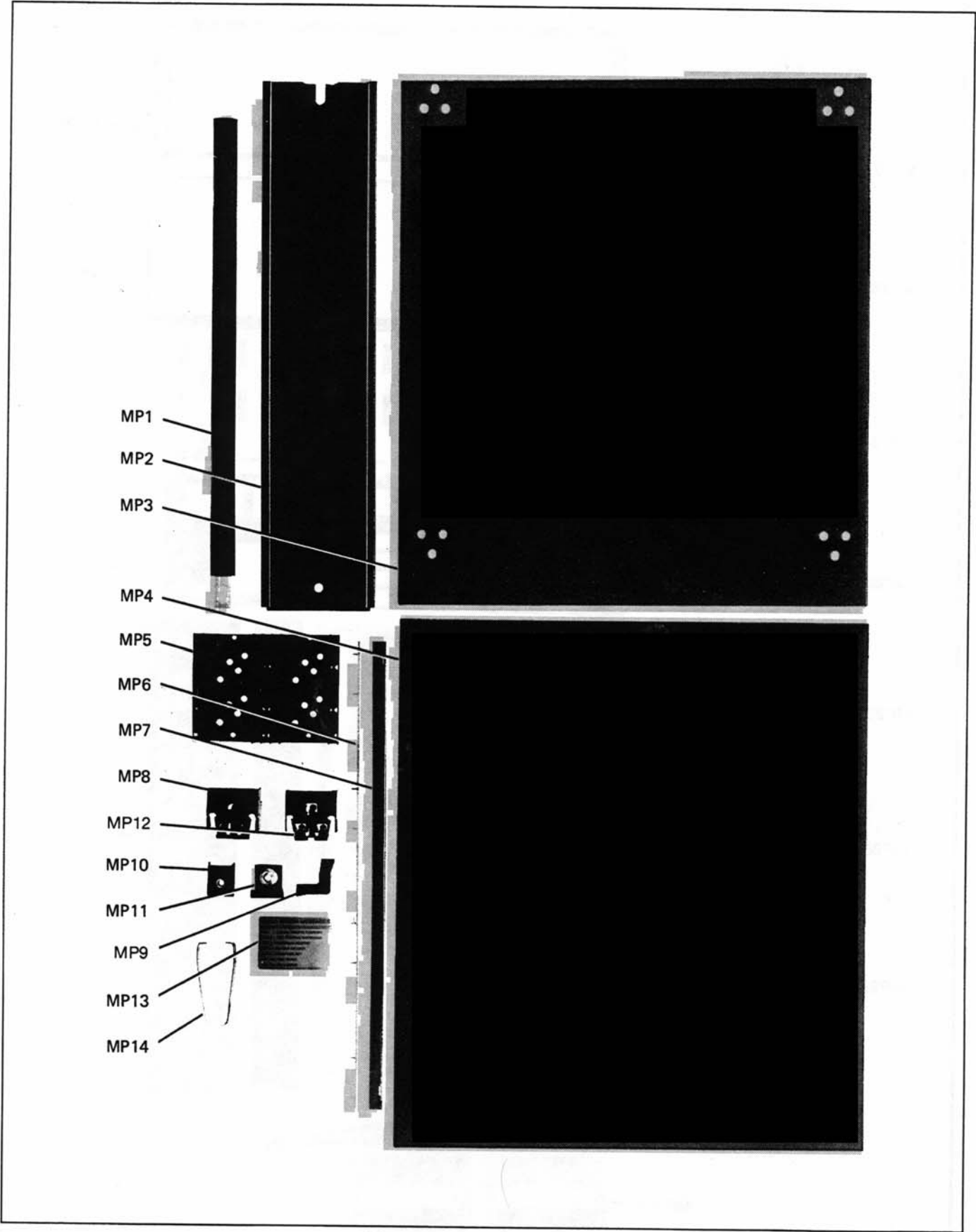

Figure 6-1. Mechanical Parts

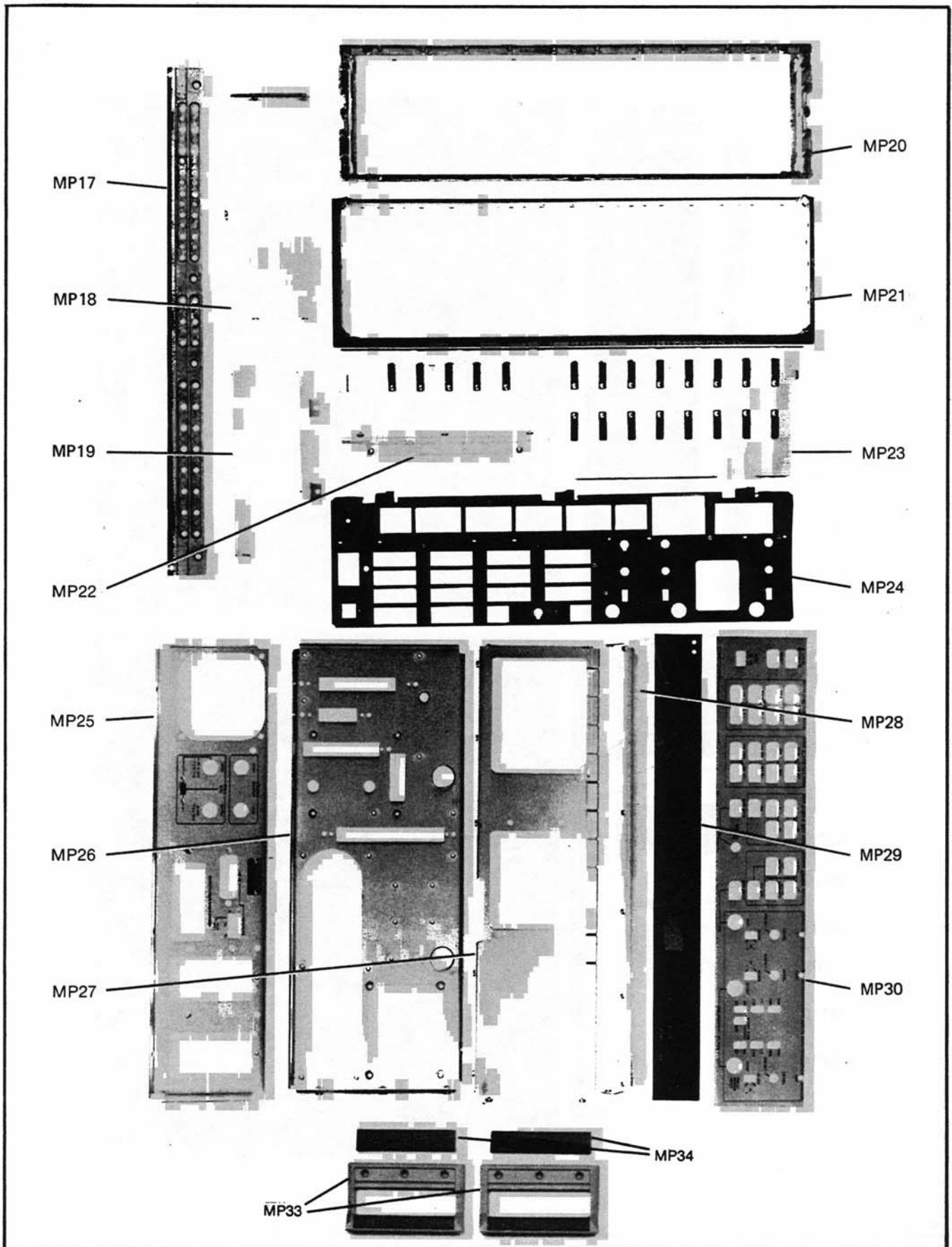

Figure 6-1. Mechanical Parts (Continued)

SECTION VII MANUAL CHANGES

7-1. INTRODUCTION

7-2. This manual has been written for, and applies directly to, instruments with the same serial number prefix as printed on the title page. This section contains information necessary to adapt this manual so it applies to older instruments.

7-3. Older Instruments

7-4. Earlier versions of this instrument (those with serial number prefixes lower than the one printed on the title page) will be slightly different than the version documented by this manual. Refer to *Table 7-1* and make the changes to this manual as indicated for your instrument's serial number prefix.

7-5. Newer Instruments

7-6. Later versions of this instrument (those with serial number prefixes higher than the one printed on the title page) will be slightly different than the version documented by this manual. Modifications to the manual so that it matches your instrument are documented in manual change information included with this manual. Replace affected pages or modify existing manual information as directed in the MANUAL UPDATING CHANGES. Contact the nearest Hewlett-Packard Sales and Service Office (listed at the back of this manual) if the change information is missing.

Table 7-1. Manual Changes by Serial Number Prefix

SERIAL NUMBER PREFIX	MAKE MANUAL CHANGES
Below 2904A02706	1
Below 2904A02391	1,2
Below 2904A02371	1 thru 3
A22 Date Code Below 89351	1 thru 4
S/N Below 2904	1 thru 5
2812A	1 thru 6
2808A	1 thru 7
2740A	1 thru 8
2732A	1 thru 9
2716A	1 thru 10
2648A	1 thru 11
2602A	1 thru 12
2528A	1 thru 13
2510A	1 thru 14
2438A	1 thru 15
2410A	1 thru 16
2332A	1 thru 17
2316A	1 thru 18

7-7. MANUAL CHANGES

CHANGE 1 (5370B below 2904A02706)

TABLE 6-2. A22 ARMING BOARD ASSEMBLY REPLACEABLE PARTS:

Change A22U22 from 1820-3699 to 1820-1399 to IC-FF ECL/10KH D-M/S POS EDGE-TRIG COM.

CHANGE 2 (5370B below 2904A02391)

Figure 8-35. A22 ARMING ASSEMBLY SCHEMATIC DIAGRAM:

>Remove connections from:

- U19A Pins 6 and 8
- U19B Pins 14 and 16
- U20A Pins 6 and 8
- U20B Pins 14 and 16
- U23B Pins 14 and 16

CHANGE 3 (5370B below 2904A02371) PCO=20220

TABLE 6-2. A9 PROCESSOR BOARD REPLACEABLE PARTS:

>Change A9U3 from 05370-80009 to 05370-80007.

CHANGE 4 (5370B, A22 Date Code below 89351)

TABLE 6-2. A22 ARMING BOARD ASSEMBLY REPLACEABLE PARTS:

- >Change A22C32 from 0160-4389 (100pf) to 0160-3877 CAPACITOR-FXD 10PF.
- >Change A22CR5, CR8 from 1902-0943 (2.4V) to 1902-3003 DIODE-BKDN 2.37V.
- >Change A22L1/L6 from 9140-1170 (1.2UH) to 9100-1788 CHOKE-WIDEBAND.
- >Change A22R1, R14, R15, R23 from 1810-0204 (1K ohm) to 1810-0030 RESISTOR-NETWORK 1K OHM X 7.
- >Change A22R2, R5, R85 from 1810-0203 (470 ohm) to 1810-0080 RESISTR-NETWRK 500 OHM X 7).
- >Change A22R20, R24 from 0698-3438 (147 ohms) to 0757-0284 (147 ohms).
- >Change A22R47 from 0757-0276 (61.9 ohms) to 0698-7207 (61.9 ohms).
- >Change A22R43 from 1810-0370 (220 ohm) to 1810-0045 RESISTOR-NETWORK 200 OHM X 7.
- >Change A22R61 from 0698-7207 (61.9 ohms) to 0757-0276 (61.9 ohms).
- >Change A22R63, R65 from 2100-3350 (200 ohm) to RESISTOR-TRMR 200 10% C SIDE-ADJ 1-TRN.
- >Change A22R71 from 0757-0438 (5.11K ohms) to 0698-4002 RESISTOR 5K 1% .12W F.
- >Change A22R104 from 0698-3154 (4.22K ohms) to 0698-5808 RESISTOR 4K 1% .12W F.
- >Add A22R106, 0757-0123 RESISTOR 34.8K 1% .12WF.
- >Delete A22R120, R128, R129, R131, R132, R134-R153, 0757-0276 RESISTOR 51.1 1% .05W F.
- >Change A22U19, U20, U23/U27 from 1820-2149 to 1820-1179 IC-DIG DUAL GATE.

TABLE 6-2. A23 DISPLAY/FRONT PANEL BOARD ASSEMBLY REPLACEABLE PARTS:

>Change A23XDS1-XDS16 from 1200-0368 to 1200-0474 SOCKET-IC 14-DIP.

FIGURE 8-35. A22 ARMING ASSEMBLY SCHEMATIC DIAGRAM:

- >Change A22C32 value from 100 PF to 10 PF.
- >Change A22CR5, CR8 value from 2.4V to 2.37V.
- >Change A22R2, R5, and R85 values from 470 ohms to 500 ohms.
- >Change A22R43 from 220 ohms to 200 ohms.
- >Change A22R71 from 5.11K ohms to 5K ohms.
- >Change A22R104 value from 4.22K ohms to 4K ohms.
- >Add A22R106 from R107 to +5V (near U7B).
- >Delete A22R120, R128, R129, R131, R132, R134-R153.

CHANGE 5 (5370B Series prefix changes from 2904A to 2812A)

TABLE 6-2. CHASSIS/MISCELLANEOUS PARTS:

- >Change MP1, STRAP HANDLE, from 5062-3704 to 5060-9804.
- >Change MP2, SIDE COVER, from 5062-3780 to 5060-9880.
- >Change PERFORATED SIDE COVER from 05359-00008 to 5061-1942.
- >Change MP3, BOTTOM COVER, from 5062-3747 to 5061-9447.
- >Change MP4, TOP COVER, FROM 5062-3735 to 5061-9435.
- >Change MP7, TOP TRIM, from 5041-8802 to 5040-7202.
- >Change MP8, FOOT NON-SKID, from 5041-8822 to 5040-7222.
- >Change MP9, STANDOFF-REAR, from 5041-8821 to 5040-7221.
- >Change MP10, STRAP HANDLE CAP FRONT, from 5041-8819 to 5041-6819.
- >Change MP11, STRAP HANDLE CAP REAR, from 5041-8820, to 5041-6820.
- >Change MP12, FOOT, from 5042-8801 to 5040-7201.
- >Change MP21, FRAME FRONT, from 5021-8403 to 5021-5803.
- >Change MP33, HANDLES, from 5062-3799 to 5061-9499.
- >Change MP34, TRIM-FRONT HANDLE ,from 5021-8496 to 5020-8896.
- >Change Option 908 Rack Flange Kit from 5062-3977 to 5061-9677.
- >Change Option 909 Rack Flange Kit from 5062-3983 to 5061-9683.
- >Change Option 913 Rack Flange from 50621-4071 to 5061-9771.

CHANGE 6 (Series Prefix Changes from 2812A to 2808A)

The following Series 2808A instruments do not include changes to A9 as indicated in Change 7:
2808A02061 thru 2808A02100

TABLE 6-2. CHASSIS/MISCELLANEOUS PARTS:

- >Delete C5 0160-4065, Qty 1, CAPACITOR-FXD .1UF \pm 20% 250VAC (RMS).
- >Add MP13, 05370-80005, LABEL-ERROR MESSAGE.

FIGURE 8-22. A1 POWER SUPPLY/MOTHER BOARD ASSEMBLY, A6 POWER SUPPLY CONTROL ASSEMBLY, A24 LINE MODULE ASSEMBLY SCHEMATIC DIAGRAM:

- >Delete C5, .1 capacitor, between the WHT/BRN/GRY and WHT/RED/GRY lines of the fan switch circuit (lower left corner).

CHANGE 7 (Series Prefix changes from 2808A to 2740A)

TABLE 6-2. A9 PROCESSOR BOARD REPLACEABLE PARTS:

- >Change A9 from 05370-60082 to 05359-60109.
- >Change A9U3 from 05370-80007 to 1818-3373 to IC-NMOS 65536 (64K) ROM.
- >Change A9XU3 from 1200-0567 (SOCKET-IC 28-CONT) to 1200-0565 SOCKET-IC 24-PIN.

Table 8-1. SERVICE:

- >Change A9 part number from 05370-60109 to 05370-60082.

FIGURE 8-26. A9 PROCESSOR ASSY COMPONENT LOCATOR/SCHEMATIC DIAGRAM:

- >Change A9 from 05370-60082 to 05370-60109.
- >Add reference to "C21 on circuit side of board".
- >Replace A9U3 with the following partial schematic:

CHANGE 8 (Series Prefix changes from 2740A to 2732A)

The following Series 2732A instruments include deletion of A19/A20 C32 as noted in Change 9:

2732A01941	2732A01950	2732A01958
2732A01943	2732A01952	2732A01959
2732A01944	2732A01954	2732A01960
2732A01946	2732A01955	
2732A01949	2732A01956	

The following Series 2732A instruments include Series 2740A changes to A21R22 and R25:

2732A01942	2732A01948	2732A01957
2732A01945	2732A01951	2732A01961
2732A01948	2732A01953	thru 02000

TABLE 6-2. A21 200MHZ MULTIPLIER REPLACEABLE PARTS:

- >Change A21 (05370-60124) SERIES to 2732.
- >Change A21R22 from 0757-0290 (6.19K) to 0698-3152 to RESISTOR 3.48K 1% .12W TF TC=0±100.
- >Change A21R25 from 0757-0439 (6.8K) to 0757-0289 RESISTOR 13.3K 1% .12W TF TC=0±100.

FIGURE 8-34. A21 200 MHz MULTIPLIER SCHEMATIC DIAGRAM/ COMPONENT LOCATOR:

- >Change A21 (05370-60124) SERIES to 2732.
- >Change A21R22 value from 6.19K ohms to 3.48K ohms.
- >Change A21R25 value from 6.81K ohms to 13.8K ohms.

CHANGE 9 (Series Prefix changes from 2732A to 2716A)

TABLE 6-2. A15 HP-IB INTERFACE REPLACEABLE PARTS:

- >Change A15 (05370-60015) SERIES to 2716.
- >Delete A15C13, 0160-4832 CAPACITOR-FXD .01UF ±10% 100VDC CER.
- >Delete A15XU11, 1200-0473 SOCKET-IC 16-PIN DIP DIP SLDR.

TABLE 6-2. A16 ARM INTERFACE REPLACEABLE PARTS:

- >Change A16 (05370-60016) SERIES to 2716.
- >Change A16C14, C15 from 0160-4040 (1000 PF) to 0160-3878 CAP-1000 PF ± 20% 100V CER.
- >Add A16C16, 0160-4832, CAPACITOR-FXD .01UF ±10% 100V CER.
- >Add A16XU2, 1200-0473, SOCKET-IC 16-CONT.

TABLE 6-2. A19 and A20 INTERPOLATOR ASSEMBLIES:

- >Delete A19/A20 C32 CAPACITOR-FXD 39PF ±5% 200VDC CER 0±30.
- >Change A19/A20 (05370-60119) SERIES to .
- >Change R28 from 0698-3435 (38.3ohms) to 0698-3432 to RESISTOR 26 1% .125W TF TC=0±100.

FIGURE 8-29. A15 HP-IB INTERFACE SCHEMATIC DIAGRAM/ COMPONENT LOCATOR:

- >Change A15 (05370-60015) SERIES to 2716.
- >Delete A15C13, .01UF, between pins 1 and 8 of A15U11.
- >Delete A15C13 (circuit side of A15 between pins 1 and 8 of U11) on Component Locator.

FIGURE 8-30. A16 ARMING INTERFACE SCHEMATIC DIAGRAM/COMPONENT LOCATOR:

- >Change A16 (05370-60016) SERIES to 2716.
- >Add A16C16, 0.01UF, to U2 PIN 1.
- >Add note "C16 on Circuit Side of Board" to Component Locator.

FIGURE 8-33. A19 START INTERPOLATOR / A20 STOP INTERPOLATOR ASSEMBLIES:

- >Change A19/A20 (05370-60119) SERIES to 2716.
- >Delete A19/A20 C32 (39 pf) from U5 pin 12 to U5 pin 14.
- >Change A19/A20 R28 value from 38.3 ohms to 26 ohms.

CHANGE 10 (Series Prefix Changes from 2716A to 2648A)

The following Series 2716A instruments include the addition of A19/A20C32: 2716A01930 thru 2716A01938, 2716A01940

The following Series 2716A instruments include the Series 2740A changes to A21R22 & R25 changes: 2716A01921, 2716A01939

TABLE 6-2. A21 200MHz MULTIPLIER REPLACEABLE PARTS:

- >Change A21 (05370-60124) SERIES to 2648.
- >Change A21R22 from 0698-3152 (3.48K) to 0698-4002 RESISTOR- 5K 1% .12W TF TC=0±100.
- >Change A21R25 from 0757-0289 (13.1K) to 0757-0444 RESISTOR 12.1K 1% .12W TF TC=0±100.
- >Change A21R26 from 0757-1094 (1.47K) to 0757-1093 RESISTOR-FXD 3K 1% .12W TF TC=0±100.

FIGURE 8-34, A21 200 MHz MULTIPLIER ASSEMBLY:

- >Change A21 (05370-60124) series to 2648.
- >Change A21R22 value from 3.48K to 5K ohms.
- >Change A21R25 value from 13.1K to 12.1K ohms.
- >Change A21R26 from 1.47K to 3K ohms.

CHANGE 11 (for 5370B with Serial Prefix 2648A and below)

Table 6-2:

- Change A6 Power Supply Control Assembly (05370-60081) from Series 2716 to Series 2552.
- Delete A6Q5 entries.
- Change A6R18 and A6R21 entries as follows: 0757-0438, RESISTOR 5.11K 1% .125W F

Figure 8-22:

- Delete Q5 and Q6 from A6 Component Locator.
- Modify A6 Power Supply Control schematic as follows:
 - Change Series Number from 2716 to 2552.
 - Delete Q5 and Q6.
 - Change value of R18 and R21 to 5.11K.
- Change A6 Reference Designations list to Q1 - Q4.

CHANGE 12 (for 5370B with Serial Prefix 2602A and below)

Table 6-2:

- Change A7 Oscillator Power Supply Assembly (05370-60007) from Series to Series 1748.
- Change A7CR1 entry as follows: 1901-0366, DIODE-FW BRIDGE 400V 1A.

Figure 8-24:

- Change A7 Oscillator Power Supply schematic from Series 2648 to Series 1748.

CHANGE 13 (for 5370B with Serial Prefix 2528A and below)

Table 6-2: A1 Mother Board Power Supply Assembly (05370-60080):

- Change Part Number from 05370-60080 to 05370-60001.
- Change Series Number from 2552 to 1748.
- Add the following entries:
 - A1K1, 0490-0908, RELAY.
 - A1XK1, 0490-0907, SOCKET.
 - A1 MISCELLANEOUS, 0490-0861, RELAY RETAINER.

Table 6-2. A6 Power Supply Control Assembly (05370-60081):

- Change Part Number from 05370-60081 to 05370-60006.
- Change Series Number from 2552 to 1748.
- Change A6R18 entry as follows: 0757-0280, RESISTOR 1K 1% .125W F TC=0±100.
- Change A6R21 entry as follows: 0757-0283, RESISTOR 2K 1% .125W F TC=0±100.
- Change A6R23, R24 entries as follows: 0811-1219, RESISTOR 250 5% 3W PW TC=0±20.

Table 8-1. Assembly Designations:

- Change A1 Part Number to 05370-60001.
- Change A6 Part Number to 05370-60006.

CHANGE 13 (Continued)

Replace paragraphs 8-90, 8-91, and 8-92 with the following:

8-90. A1, A6, Power Supply Motherboard/Power Supply Control Assembly

8-91. The Power Supply Motherboard/Power Supply Control Assembly (A1, A6) supplies all dc power for the instrument, except for the Crystal Oven Oscillator. The ac line voltage enters through the Power Module (correct selection of line input voltage determined by Power Module card) to the Power Transformer primary windings and to the instrument fan. The secondaries of the power transformer are rectified and filtered and sent to the Power Relay. A separate transformer secondary supplies power to the Oven Oscillator Power Supply (A7).

8-92. When the front panel ON-STANDBY switch is activated, AC power is sent to the fan and unregulated dc is sent to the Power Relay, enabling the four unregulated dc voltages to the Power Supply Control Assembly (A6). The A6 assembly then converts the four unregulated dc voltages +10, +20V, -20V, and -10V (fused at the input) to +5V, +15V, -15V, and -5.2V for distribution throughout the instrument. These voltages are supplied by four, separate linear series-pass regulators which are referenced to a single +10.0V precision reference IC (A6U5).

Replace paragraphs 8-143 thru 8-148 with the following:

8-143. A6 Power Supply

8-144. The A1, A6 assemblies provide +5V, -5.2V, +15V, and -15V for distribution throughout the 5370B. These four supplies are derived in a similar fashion. For these reason, only one of the supplies (+5V) will be discussed.

8-145. The Power Transformer (T1) is connected to the AC supply whenever the 5370B is connected to the line. This is done to provide power (from the 16V ac secondary winding) to the Oscillator Oven Power Supply (A7) to maintain the crystal oven at a constant temperature even through the 5370B is in the standby mode. The four remaining secondaries are rectified, filtered and sent to relay K1 which, then energized by the front panel power switch, connects the supplies with the Regulator Assembly A6 to be regulated and distributed.

8-146. The unregulated dc enters the A6 board, which is fused at each of the four inputs, and is routed to the collector of the series pass transistor (all four series pass transistors are power darlington). The +20V unregulated (used for the +15V supply) is sent to a precision regulator (U5) which is the reference supply (10.0V) for the four controlling op amps U1, U2, U3, and U4. The output is from the emitter of the series pass transistor. It is current limited by A6Q2 and R2. In a normal state, Q2 is turned off. As the current through R2 increases, the voltage drop across R2 increases. As the voltage drop approaches the bias voltage of A6Q2, A6Q2 starts to turn on. When A6Q2 turns on, it pulls current away from the base of the power transistor turning it less on.

8-147. Diode CR2 is a 6V zener used to clamp the +5V supply in case the power transistor shorts. CR2 will withstand enough current to open the fuse F2. R7 and DS3 are a monitor to quickly show if the supply is present. R13 is a base current limiter for the power darlington.

8-148. The controller is an op amp connected as a linear voltage comparator. The plus (reference) input (U2 pin 3) is set at +5.05 volts by the resistor voltage divider of R12 and R14. The minus (sense) input is connected to the output of the supply. As the supply varies, the output U2(6) varies to hold the supply at +5.05V. The supply is slightly higher than 5.00V to compensate for the voltage drop throughout the 5370B motherboard traces.

CHANGE 13 (Continued)

Figure 8-21:

Replace A6 Power Supply Control Assembly with the following:

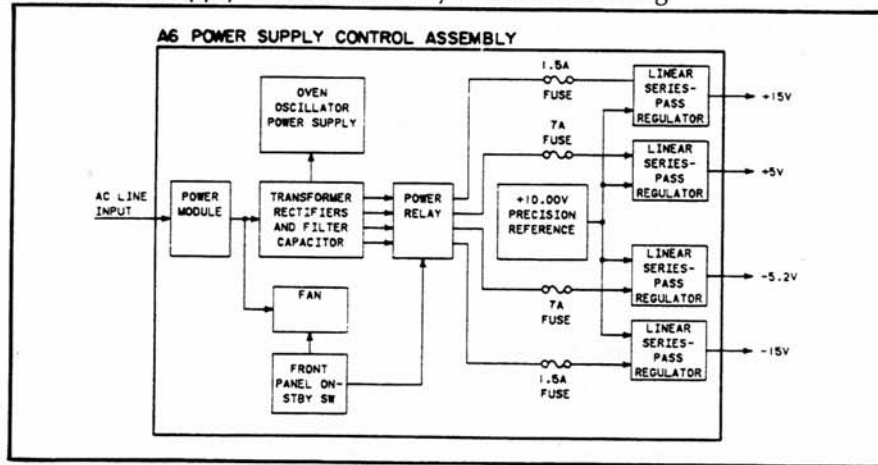

Figure 7-1. Part of Simplified/Overall Block Diagram

Replace Figure 8-22, with Figures 7-2 and 7-3.

CHANGE 14 (for 5370B with Serial Prefix 2510A and below)

Table 6-2:

Change A19/A20 Interpolator Assembly (05370-60119) from Series 2528 to Series 2016.

Table 6-2:

Change A19R17 entry as follows: 0698-7212, 9, 1, RESISTOR 100 1% .05W F TC=0±100, 24546, C3-1/8-TO-100R-F.

Change A19R28 entry as follows:

0698-3435, 0,1, RESISTOR 38.3 1% .125W F TC=0+-100,24546,C4-1/8-TO-38R3-F.

Figure 8-33:

Change A19/A20 Interpolator Assembly from Series 2528 to Series 2016.

Change value of R17 to 100 ohms.

Change value of R28 to 38.3 ohms.

CHANGE 15 (for 5370B with Serial Prefix 2438A and below)

Table 6-2:

Change CHASSIS PARTS entries as follows:

MP3, 5060-9847, 4,1, COVER-BOTTOM ASSY (INCH), 28480, 5060-9847.

MP4, 5060-9835, 0,1, COVER-TOP ASSY (INCH), 28480, 5060-9835.

MP10, 5040-7219, 8, 2, STRAP HANDLE CAP-FRONT (INCH), 28480, 5040-7219.

MP11, 5040-7220, 1, 2, STRAP-HANDLE CAP-REAR (INCH), 28480-5040-7220.

MP17, 5040-8837, 6, 4, CORNER STRUT (INCH), 28480, 5020-8837.

MP20, 5020-8804, 7, 1, FRAME-REAR (INCH), 28480, 5020-8804.

MP21, 5020-8803, 6, 1, FRAME-FRONT (INCH), 28480, 5020-8803.

MP33, 5060-9899, 6, 2, HANDLES (INCH), 28480, 5060-9899.

Change MISCELLANEOUS entries as follows:

From 0515-0896 to 2510-0195, 9, 6, SCREW-MACH 8-32 .375-IN-LG.

From 0515-1005 to 2510-0192, 6, 8, SCREW-MACH 8-32 .25-IN-LG.

From 0515-1132 to 2680-0172, 1, 4, SCREW-MACH 10-32 .375-IN-LG.

From 0515-1331 to 2510-0192, 6, 8, SCREW-MACH 8-32 .25-IN-LG.

Change OPTIONS entries as follows:

5061-0089, (Option 907) FRONT HANDLE ASSY (INCH), 28480, 5060-0089.

5061-0083, (Option 909) RACK MOUNT FLANGE KIT-INCL HANDLES (INCH).

5061-2071, (Opt 913) RACK, MOUNT KIT FOR CABINETS W/FRONT HANDLES (INCH).

CHANGE 16 (for 5370B with Serial Prefix 2410A and below)

NOTE

The following 2410A Serial Prefix instruments contain the 2438A instrument modifications. For these 2410A instruments, make only the manual changes indicated in *Table 7-1* for 2438A Serial Prefix instruments:

2410A00732	2410A00763
736	00769 thru 00777
752	00779 thru 00910
760	

Table 1-1:

Change INPUT AMPLIFIERS specification as follows:

SEPARATE INPUTS: Impedance: Selectable 1 Megohm || <45 pF(1) or 50 Ω NOMINAL.

Table 6-2:

Change A3 Input Amplifier Assembly (05345-60138) from Series 2438 to Series 2316.

Change A3C10 entry as follows: 0160-5603, 5, 2, CAPACITOR 33 PF +-5% 1KVDC CER, 72982.

Change A3C16 entry as follows: 0160-0552, 2, 2, CAPACITOR 100PF +-10% 50VDC CER, 28480, 0160-0552.

Change A3C24 entry as follows:

0160-4062, 2, CAPACITOR-FXD 470PF +-10% 50VDC CER, 28480,0160-4062.

Change A3C34 entry as follows:

0160-5603, 5, CAPACITOR-FXD 33PF +-5% 1KVDC CER, 72982.

Delete A3C45 and C46 entries.

Table 6-2:

Change A3 R16 entry as follows:

0757-0127, 4, RESISTOR 215K 1% .5W F TC=0+-100, 28480, 0757-0127.

Change A3R21 entry as follows:

0698-8381, 5, 4, RESISTOR 50 5% .1W C TC=0+-200, 28480,0698-8381.

Change A3R22, R28 entry as follows:

0698-8881, 0, 2, RESISTOR 900K 5% .3W C TC=0+-200, 28480, 0698-8881.

Change A3R29 entry as follows:

0698-8381, 5, RESISTOR 50 5% .1W TC=0+-200, 28480, 0698-8381.

Change A3R36 entry as follows:

0757-0127, 4, RESISTOR 215K 1% .5W F TC=0+-100, 28480,0757-0127.

Table 6-2:

Change A3R56, R57 entry as follows:

0698-8381, 5, RESISTOR 50 5% .1W C TC=0+-100, 28480, 0698-8381.

Figure 8-23:

Change A3 Input Amplifier Assembly from Series 2438 to Series 2316.

Change value of C10 to 33 PF.

Change value of C16 to 100 PF.

Change value of C24 to 470 PF.

Change value of C34 to 33 PF.

Delete C45 and C46.

Change value of R16 and R36 to 215K.

Change value of R21 and R29 to 50 ohm.

Change value of R56 and R57 to 50 ohm.

Change A3 Reference Designators table to C22-C44.

CHANGE 17 (for 5370B with Serial Prefix 2332A and below)

Table 6-2:

Change A15 HP-IB Interface Assembly (05370-60015) from Series 2410 to 1748A.

Change A15U5 entry as follows:

1820-1207, 2, 1, IC GATE TTL LS NAND 8I-INP, 01295, SN74LS30N.

Figure 8-29:

Change A15 HP-IB Interface Assembly from Series 2410 to Series 1748.

CHANGE 18 (for 5370B with Serial Prefix 2316A)

Table 6-2:

Change A4 Interconnect Assembly to 05345-60104 (Series 2316).

Change A9 Processor Assembly (05370-60109) from Series 2332 to Series 2316.

Delete A9C21 entry.

Change A16 Arm interface Assembly (05370-60016) from Series 2332 to Series 2012).

Delete A16C16 entry.

Figure 8-26:

Change A9 Assembly from Series 2332 to Series 2316.

Delete A9C21.

Figure 8-30:

Change A16 Assembly from Series 2332 to Series 2012.

Delete C16.

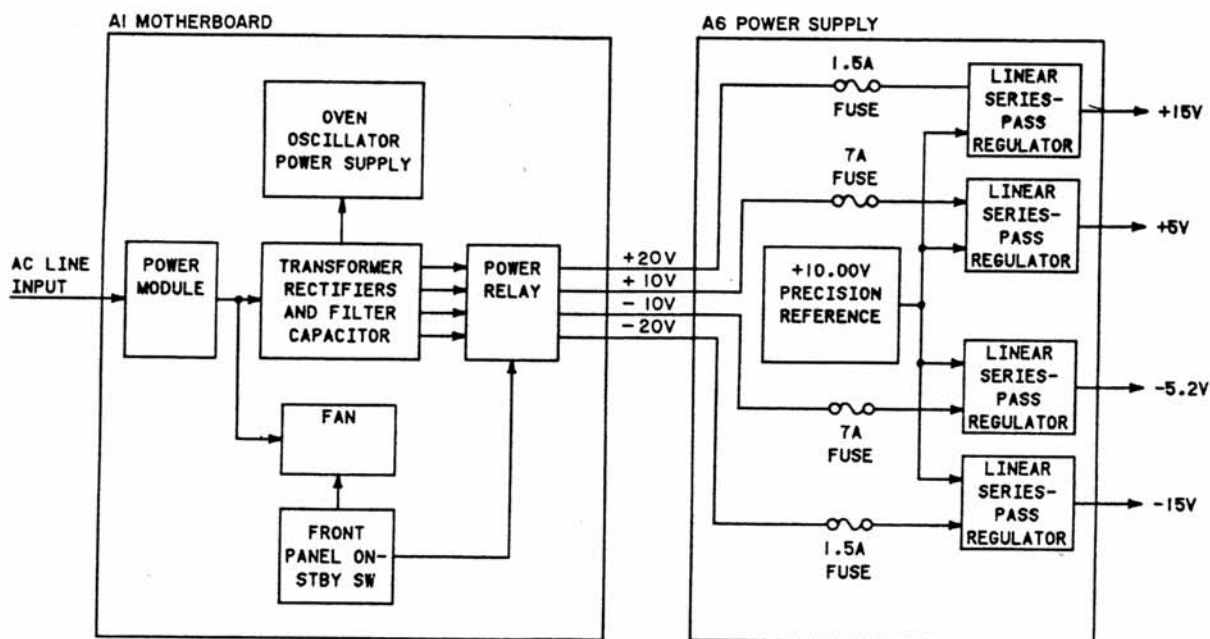

**A1 POWER SUPPLY MOTHERBOARD ASSEMBLY
A6 POWER SUPPLY CONTROL ASSEMBLY**

The Power Supply Motherboard/Power Supply Control Assemblies (A1, A6) supply all DC power for the instrument, except for the Option 001 Oven Oscillator. The AC line voltage enters through the Power Module (correct selection of line input voltage determined by Power Module card) to the Power Transformer primary windings and to the instrument fan. The secondaries of the power transformer are rectified and filtered and sent to the Power Relay. A separate transformer secondary supplies power to the Oven Oscillator Power Supply (A7) (Option 001).

When the front panel ON-STANDBY switch is activated, AC power is sent to the fan and unregulated DC is sent to the Power Relay, enabling the four unregulated DC voltages to the Power Supply Control Assembly (A6). The A6 assembly then converts the four unregulated DC voltages +10V, +20V, -20V, and -10V (fused at the input) to +5V, +15V, -15V, and -5.2V for distribution throughout the instrument. These voltages are supplied by four, separate linear series-pass regulators which are referenced to a single +10.0V precision reference IC (A6U5).

Figure 7-2. A1 Power Supply Motherboard, A6 Power Supply Control Assembly

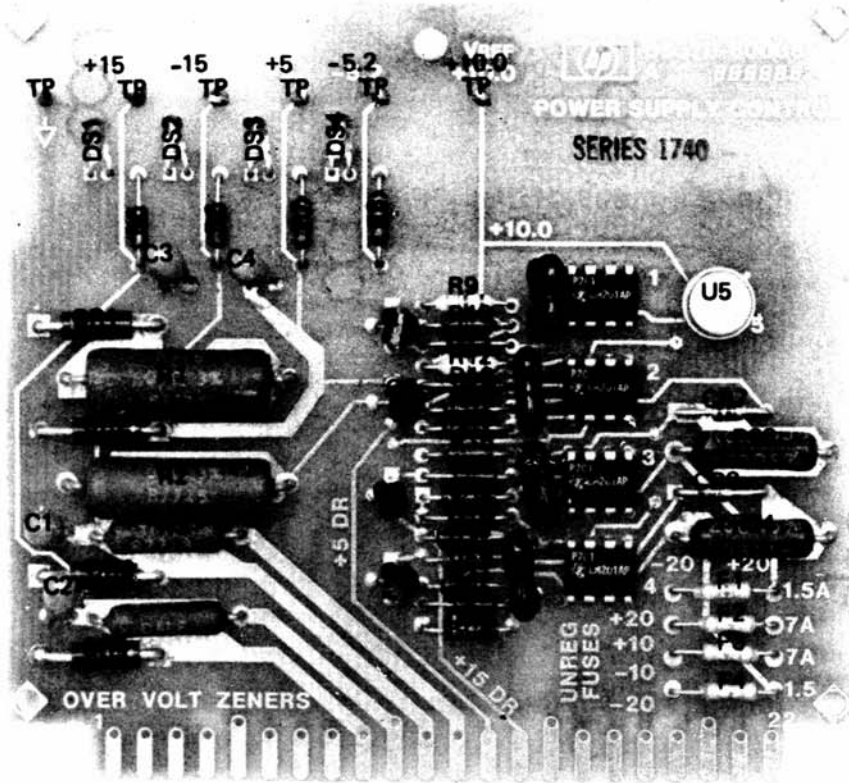

A6

First part of page 7-13, which pulls out.

FROM A60 { XA7 XA8

T1
POWER TRANSFORMER

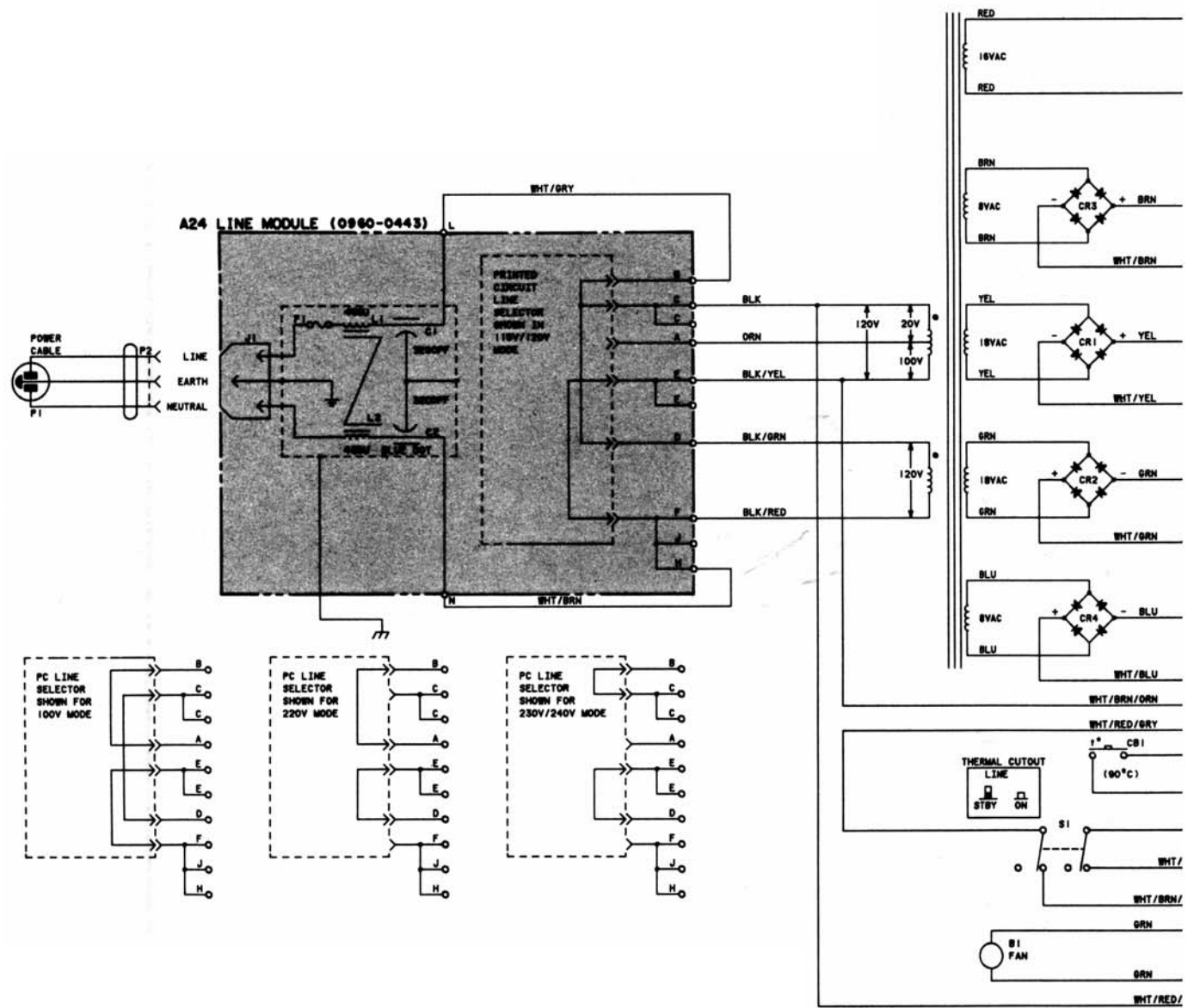

Second part of page 7-13, which pulls out.

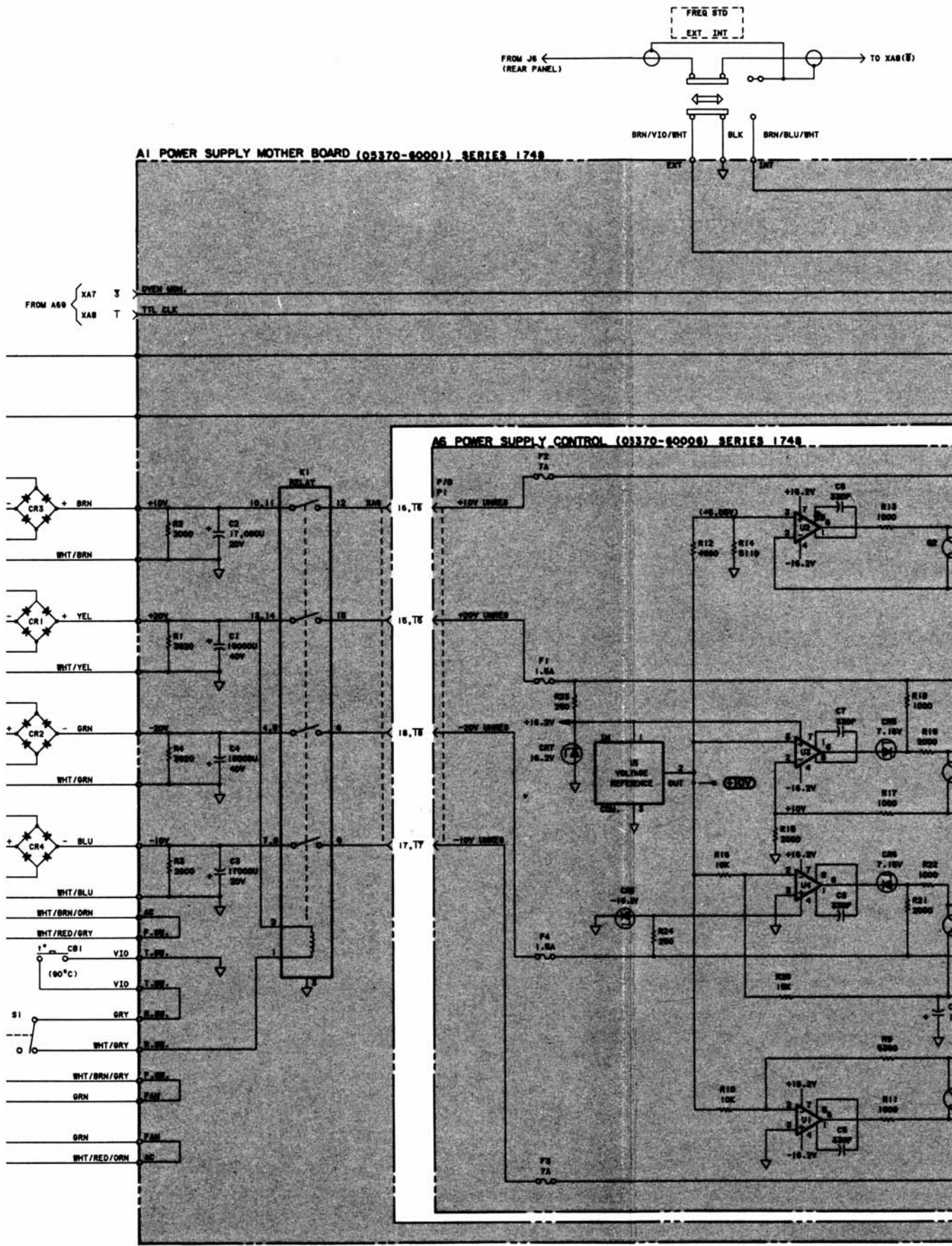

Third part of page 7-13, which pulls out.

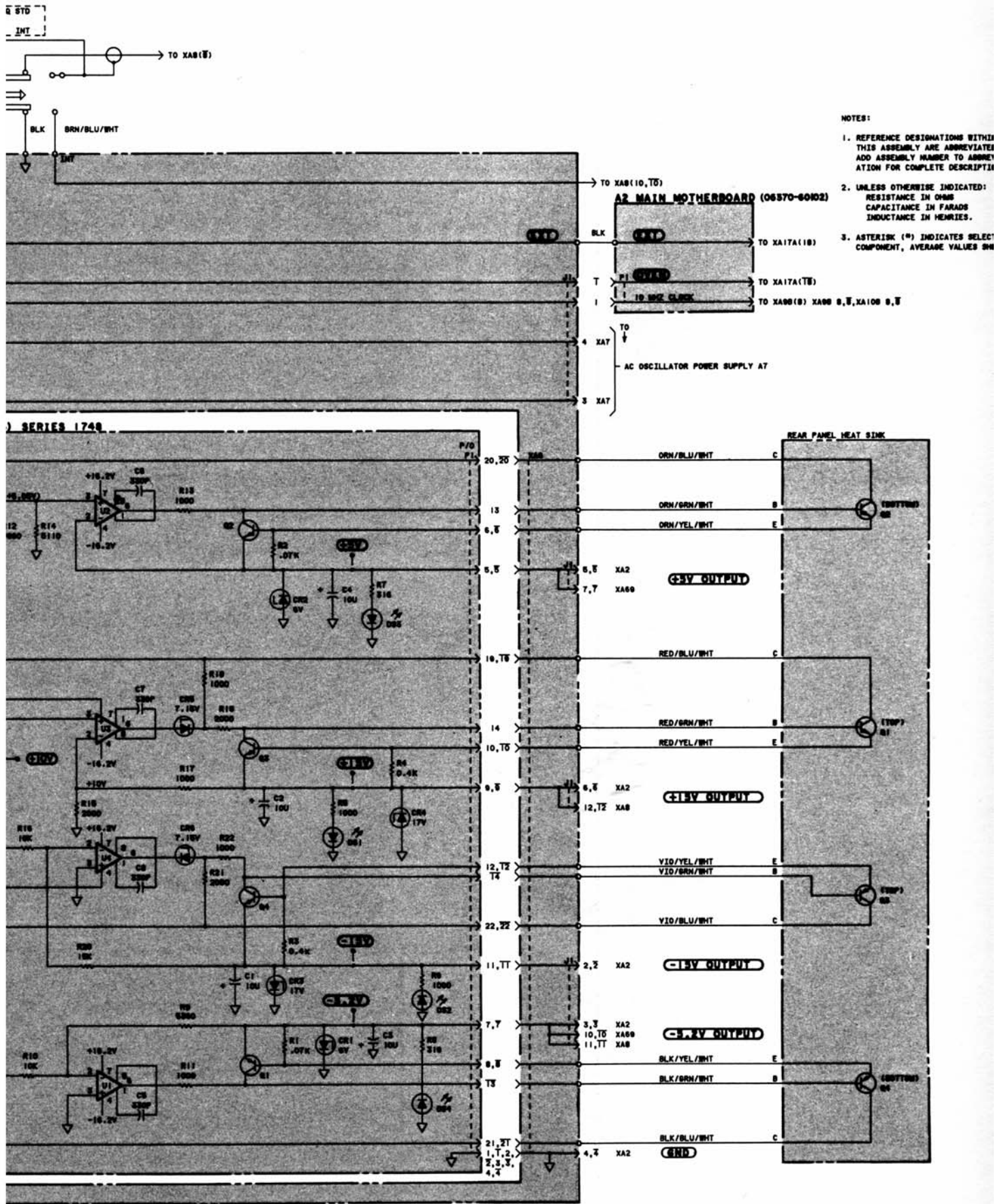
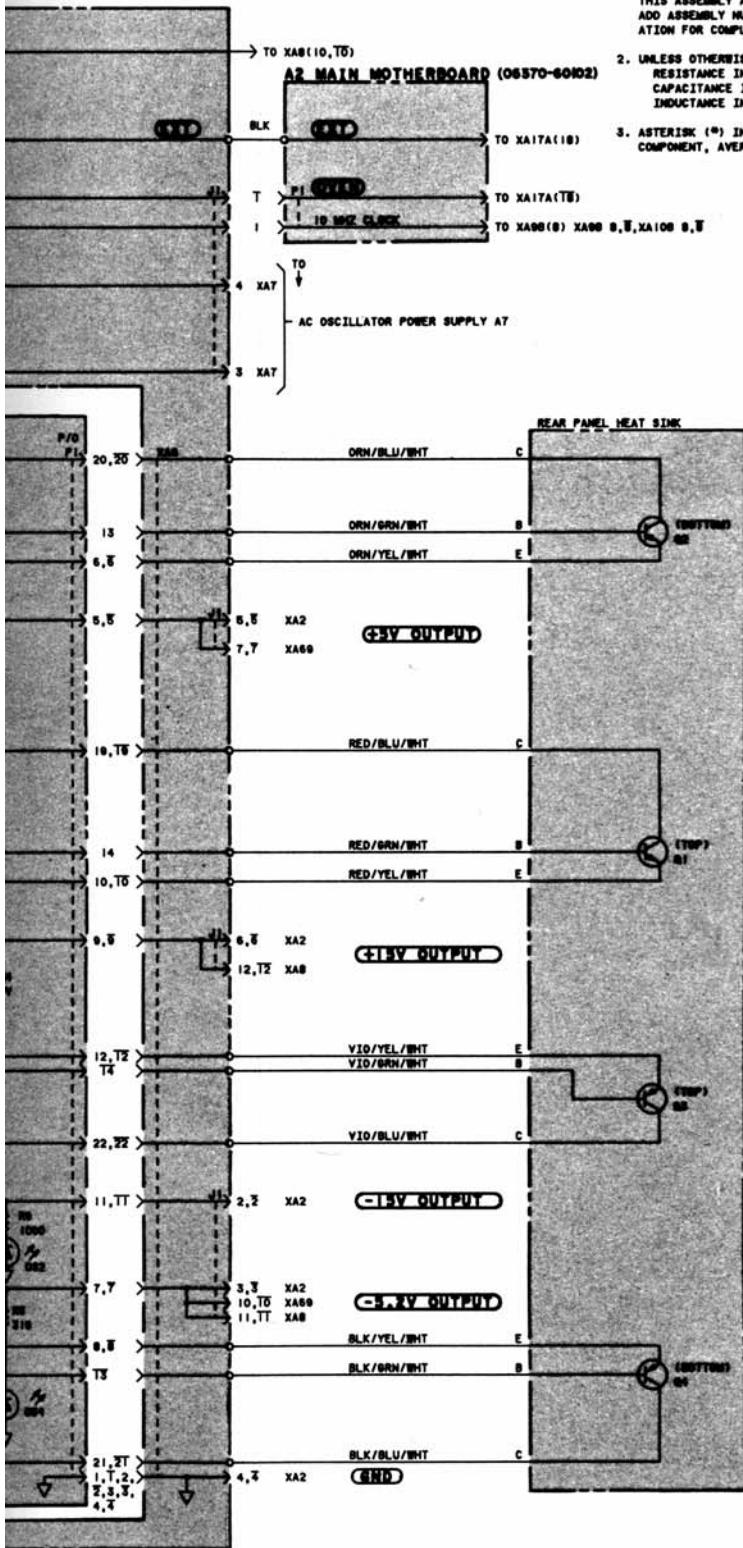

Figure 7-3. A1 PO

Fourth part of page 7-13, which pulls out.

NOTES:

1. REFERENCE DESIGNATIONS WITHIN THIS ASSEMBLY ARE ABBREVIATED. ADD ASSEMBLY NUMBER TO ABBREVIATION FOR COMPLETE DESCRIPTION.
2. UNLESS OTHERWISE INDICATED: RESISTANCE IN OHMS, CAPACITANCE IN FARADS, INDUCTANCE IN HENRIES.
3. ASTERISK (*) INDICATES SELECTED COMPONENT, AVERAGE VALUES SHOWN.



A1 Reference Designations	A2 Reference Designations	A6 Reference Designations
C1-4 J1 K1 R1-4	C1-8 J1 R1-8	C1-8 CR1-8 DS1-4 F1-4 Q1-4 R1-24 U1-5
A6 TABLE OF ACTIVE ELEMENTS		
Reference Designations	HP Part Number	Mfr. Part Number
CR1, CR2	1902-0522	1N5340B
CR3, CR4	1902-0632	1N5354B
CR5, CR6	1902-0074	1902-0074
CR7, CR8	1902-0783	1902-0783
DS1-DS4	1990-0620	5082-4584
Q1, Q4	1853-0036	1853-0036
Q2, Q3	1854-0215	2N3904
U1-U4	1820-0477	LM301AN
U5	1826-0316	LH0070-1H

Figure 7-3. A1 POWER SUPPLY/MOTHERBOARD ASSEMBLY,
A6 POWER SUPPLY CONTROL ASSEMBLY,
A24 LINE MODULE ASSEMBLY

Figure 7-3

**A1 POWER SUPPLY/MOTHERBOARD ASSEMBLY,
A6 POWER SUPPLY CONTROL ASSEMBLY,
A24 LINE MODULE ASSEMBLY**

(See Page 7-13)

SECTION VIII SERVICE

WARNING

LINE VOLTAGE IS EXPOSED WITHIN THE 5370B EVEN WHEN THE POWER SWITCH IS IN THE STBY POSITION. REMOVAL OF THE POWER CORD IS REQUIRED TO FULLY UNPOWER THE 5370B.

8-1. INTRODUCTION

8-2. This section contains the information needed to service the HP 5370B. The information includes recommended test equipment, schematic diagram notes, safety considerations, 10870A service accessory kit, signal descriptions, cable destinations, replacing front panel lights, push-button switch removal, block diagram theory, detailed theory, troubleshooting, microprocessor address mapping, and schematic diagrams. This section also includes a cross-reference table, *Table 8-1*, to aid the correlation of assembly reference designations with their HP part numbers.

Table 8-1. Assembly Designations

REFERENCE DESIGNATION	DESCRIPTION	HP PART NUMBER
A1	Power Supply/Motherboard Assembly	05370-60080
A2	Main Motherboard Assembly	05370-60102
A3	Input Amplifier Assembly	05345-60138
A4	Interconnect Board Assembly	05345-60124
A5	HP-IB Input Connector Assembly	05370-60005
A6	Power Supply Control Assembly	05370-60081
A7	Oven Oscillator Power Supply Assembly	05370-60007
A8	Reference Frequency Buffer Assembly	05370-60008
A9	Processor Assembly	05370-60082
A10	NOT USED	-
A11	Display Interface Assembly	05370-60011
A12	NOT USED	-
A13	NOT USED	-
A14	Service Aid Assembly (Part of Service Accessory Kit Part Number 10870A)	05370-60014
A15	HP-IB Interface Assembly	05370-60015
A16	Arming Interface Assembly	05370-60016
A17	Count Chain Assembly	05370-60017
A18	DAC/NO Logic Assembly	05370-60218
A19	Start Interpolator Assembly	05370-60119
A20	Stop Interpolator Assembly	05370-60119
A21	200 MHz Multiplier Assembly	05370-60124
A22	Arming Assembly	05370-60122
A23	Front Panel Display Assembly	05370-60123
A24	Filtered Line Module	0960-0443
A69	10 MHz Oscillator Assembly	10811-60111

8-3. THEORY OF OPERATION

8-4. There are two theories of operation. The first is a block theory. That is, an overview of the 5370B is presented. The block theory is assembled to follow the block diagram in *Figure 1-6*. The second is a detailed theory. It describes in detail, the circuit operation of all assemblies. All references are made to the schematic diagrams located at the end of this section.

8-5. TROUBLESHOOTING

8-6. The troubleshooting is located near the end of this section right before the schematic diagrams. Use the flowchart in *Figure 8-7* to isolate the problem to the particular assembly. The troubleshooting that follows *Figure 8-7* is used to locate the faulty component. The troubleshooting refers to mapping and signature analysis techniques. An explanation of the purpose and use of mapping in troubleshooting is provided in paragraphs 8-249 through 8-252.

8-7. RECOMMENDED TEST EQUIPMENT

8-8. Test equipment and test equipment accessories required to maintain the 5370B are listed in *Table 1-2*. Equipment other than that listed may be used if it meets the listed critical specifications.

8-9. SCHEMATIC DIAGRAM NOTES

8-10. *Figure 8-1* shows the symbols used on the schematic diagrams. *Figure 8-1* also shows the method for assigning reference designators, assembly numbers, and subassembly numbers.

8-11. Reference Designations

8-12. Assemblies such as printed circuit boards are assigned numbers in sequence, A1, A2, etc., as shown in *Table 8-1*. As shown in *Figure 8-1*, subassemblies within an assembly are given a subordinate A number. For example, rectifier subassembly A1 has the complete designator A25A1. For individual components, the complete designator is determined by adding the assembly number and subassembly number, if any. For example, CR1 on the rectifier assembly is designated A25A1CR1.

8-13. Identification Markings on Printed Circuit Boards

8-14. HP printed circuit boards (see *Figure 8-1*) have four identification numbers; an assembly part number, a series number, a revision letter, and a production code. The assembly part number has 10 digits (such as 05340-60037) and is the primary identification. All assemblies with the same part number are interchangeable. When a production change is made on an assembly that makes it incompatible with previous assemblies, a change in part number is required. The series number (such as 1248) is used to document minor electrical changes. As changes are made, the series number is incremented. When replacement boards are ordered, you may receive a replacement with a different series number. If there is a difference between the series number marked on the board and the schematic in this manual, a minor electrical difference exists. If the number on the printed circuit board is lower than that on the schematic, refer to Section VII for backdating information. If it is higher, refer to the yellow loose-leaf manual change sheets for this manual. If the manual change sheets are missing, contact your local HP Sales and Support Office. See the listing at the back of this manual.

8-15. Revision letters (A, B, etc.) denote changes in printed circuit layout. For example, if a capacitor type is changed (electrical value may remain the same) and requires different spacing for its leads, the printed circuit board layout is changed and the revision letter is incremented to the next letter. When a revision letter changes, the series number is also usually changed. The production code is the four-digit, seven-segment number used for production purposes.

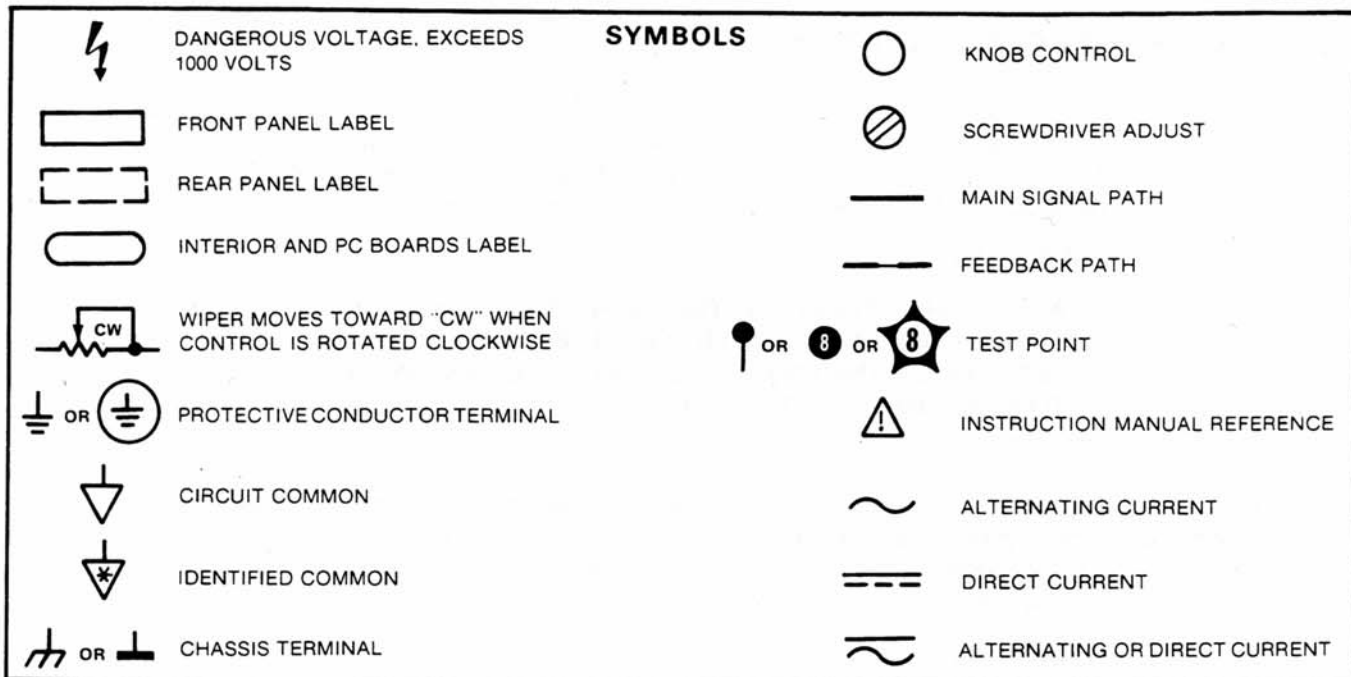

PRINTED CIRCUIT BOARD IDENTIFICATION

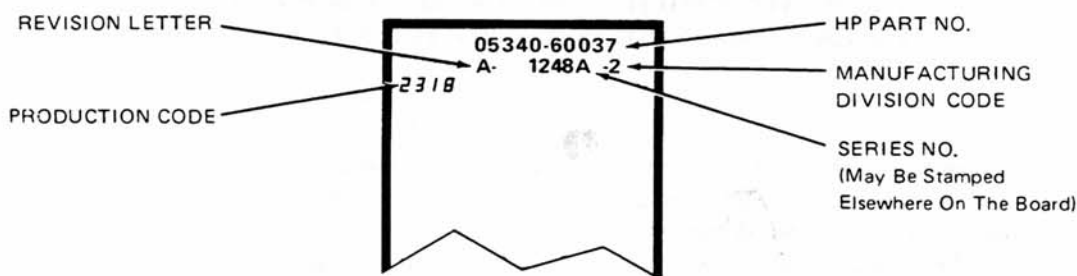

REFERENCE DESIGNATIONS

REFERENCE DESIGNATIONS WITHIN ASSEMBLIES ARE ABBREVIATED. ADD ASSEMBLY NUMBER TO ABBREVIATION FOR COMPLETE DESCRIPTION. JACKS ARE THE STATIONARY CONNECTORS AND PLUGS ARE THE MORE MOVEABLE OF TWO CONNECTORS.

<u>ASSEMBLY</u>	<u>ABBREVIATION</u>	<u>COMPLETE DESCRIPTION</u>
A25	CR1	A25CR1
A25A1	CR1	A25A1CR1
NO PREFIX	J3	J3

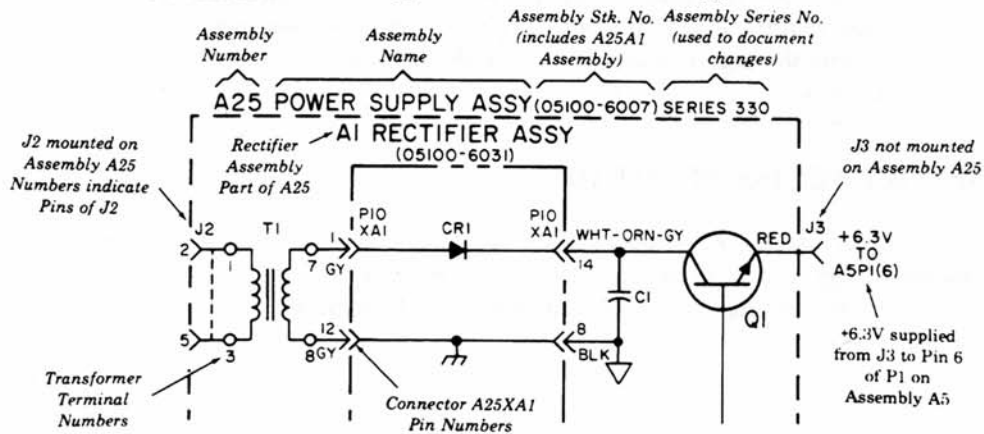

Figure 8-1. Schematic Diagrams Notes

8-16. SAFETY CONSIDERATIONS

8-17. Although the 5370B has been designed in accordance with international safety standards, this manual contains information, cautions, and warnings which must be followed to insure safe operation and to retain the 5370B in safe operating condition (also see Sections II, III, V). Service and adjustments should be performed only by qualified service personnel.

WARNING

ANY INTERRUPTION OF THE PROTECTIVE (GROUNDING) CONDUCTOR (INSIDE OR OUTSIDE THE 5370B) OR DISCONNECTION OF THE PROTECTIVE EARTH TERMINAL IS LIKELY TO MAKE THE 5370B DANGEROUS.

8-18. Any adjustment, maintenance, and repair of the opened 5370B under voltage should be avoided as much as possible and, when inevitable, should be carried out only by a skilled person who is aware of the hazard involved. Capacitors inside the 5370B may still be charged even if the 5370B has been disconnected from its source of power.

WARNING

LINE VOLTAGE IS EXPOSED WITHIN THE 5370B EVEN WHEN THE POWER SWITCH IS IN STANDBY. REMOVAL OF THE POWER CORD IS NECESSARY TO FULLY UNPOWER THE 5370B.

8-19. Make sure that only fuses with the required rated current and of the specified type (normal blow, time delay, etc.) are used for replacement. The use of repaired fuses and the short-circuiting of fuseholders must be avoided. Whenever it is likely that this protection has been impaired, the 5370B must be made inoperative and be secured against any unintended operation.

WARNING

THE SERVICE INFORMATION IS OFTEN USED WITH POWER SUPPLIED AND PROTECTIVE COVERS REMOVED FROM THE 5370B. ENERGY AVAILABLE AT MANY POINTS MAY, IF CONTACTED, RESULT IN PERSONAL INJURY.

CAUTION

Series pass transistor cases on rear panel have voltage on them and require insulators between them and the heatsink. Power supply damage is inevitable if transistor cases are shorted to the chassis.

8-20. SERVICE ACCESSORY KIT 10870A

8-21. The 10870A Service Accessory Kit contains seven special extender boards and a Service Aid PC assembly (*Figure 8-2*) designed to aid in troubleshooting the 5370B. The following paragraphs describe equipment supplied, replaceable parts and operation.

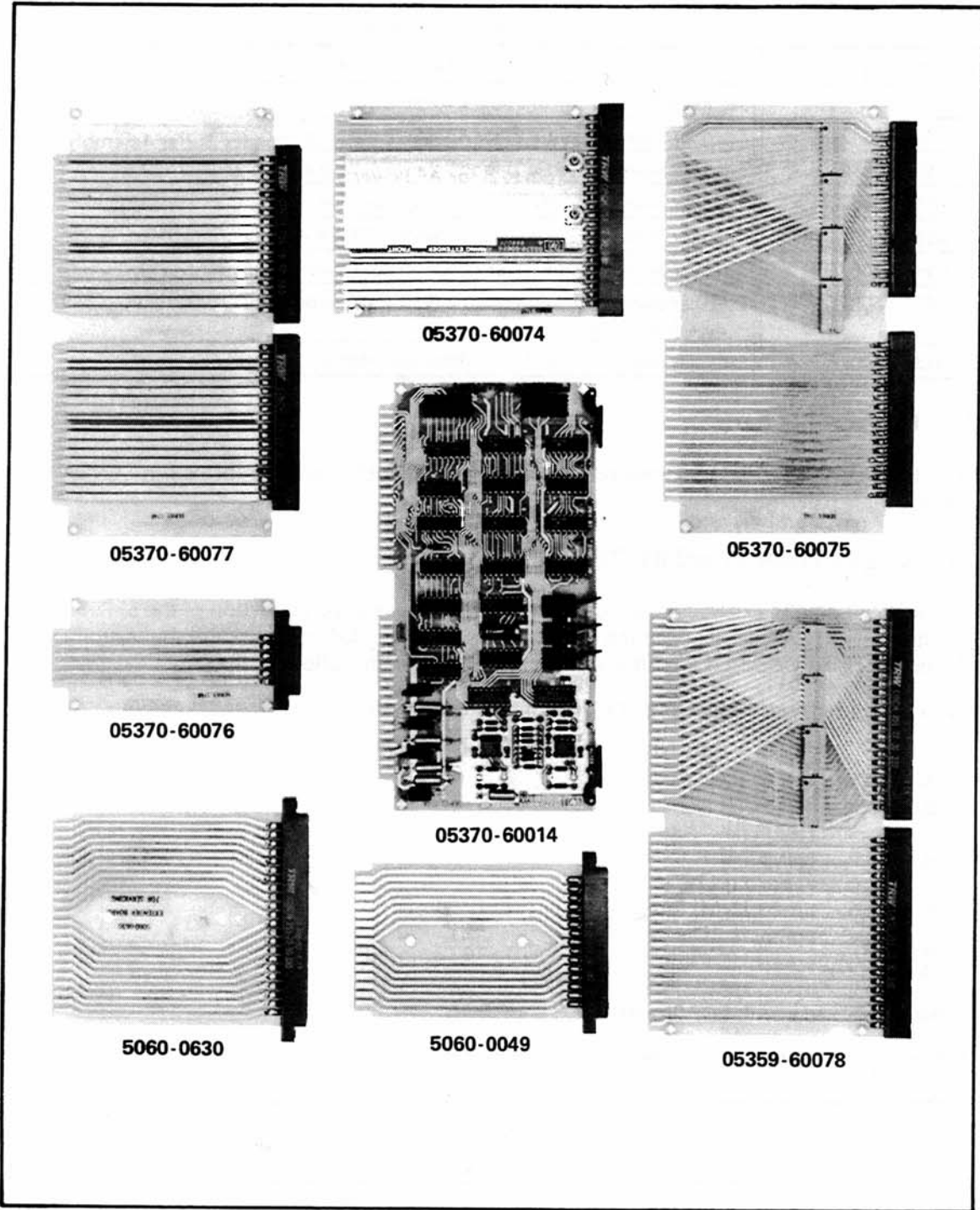

Figure 8-2. 10870A Service Accessory Kit

8-22. Equipment Supplied

8-23. Table 8-2 lists the boards contained in the 10870A Service Accessory Kit with their general description and usage.

Table 8-2. 10870A Kit Contents

HP PART NUMBER	DESCRIPTION
05370-60014	Service Aid Board (HP 5370B A14 Assembly)
5060-0049	Extender Board (15 pin × 2) for A8 Reference Frequency Buffer Assembly
5060-0630	Extender Board (22 pin × 2) for A6 Power Supply Assembly
05370-60074	Extender Board for 5370B A22 Arming Assembly
05370-60075	Extender Board for Digital Section (except 5359A A16)
05370-60076	Extender Board (6 pin × 2) for A7 Oscillator Power Supply (for 5359A/5370B)
05730-60077	Extender Board for Analog Section (5370B A9 through A21 Assemblies) (5359A A24 Assembly)
05359-60078	Extender Board for 5359A A16 Processor Interface Assembly

8-24. Replaceable Parts

8-25. HP part numbers and information for ordering replaceable parts are located in Section VI, A14 replaceable parts list.

8-26. Using Extender Board 05370-60075

8-27. The 05370-60075 Extender Board is used to troubleshoot the digital section of the 5370B. The four switch packs (32 switches) open the lines between the extended pc board and the instrument's motherboard. Using *Figure 8-3* for reference, the switches open the following lines:

SW1 switches a through h open the data lines LD0 through LD7, respectively.

SW2

- a. opens L(R/W) line
- b. opens MEM CLK line
- c. opens LIRQ line
- d. opens LNMI line
- e. opens H RUN line
- f. opens HEN line
- g. opens HRDY line
- h. opens L RST line

SW3 (a through h) open address lines LA0 through LA7, respectively.

SW4 (a through h) open address lines LA8 through LA15, respectively.

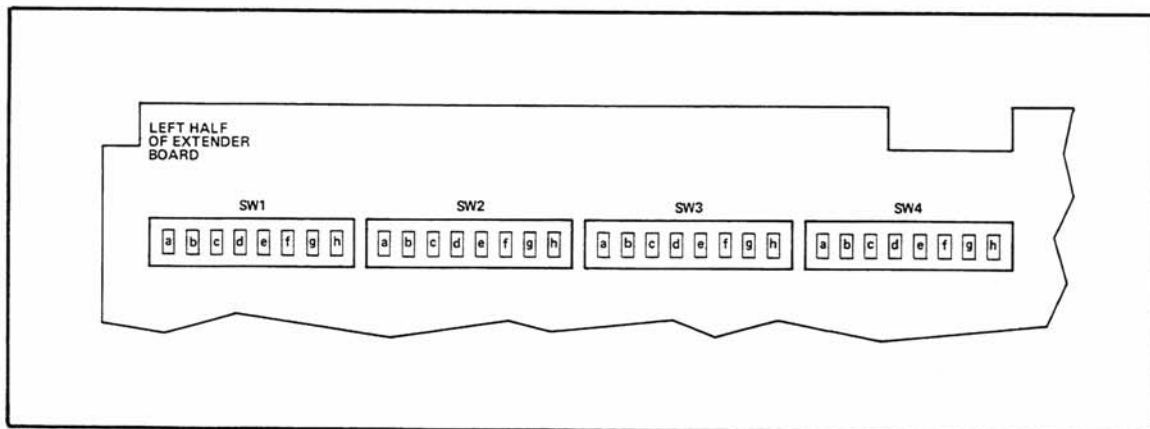

Figure 8-3. 05370-60075 Partial View

8-28. Theory of Operation (05370-60014)

8-29. INTRODUCTION. The following paragraphs contain the theory of operation for the 05370-60014 Service Aid Assembly. Block theory is first given according to the Block Diagram in *Figure 8-4*, followed by detailed theory which is in reference to the 05370-60014 schematic. The 05370-60014 schematic is located in *Figure 8-28*.

8-30. BLOCK THEORY. The 05370-60014 can be divided into two main sections. The first main section is called the breakpoint section. It contains four comparators and four registers (latches) which are used via the HP-IB to halt the microprocessor program routine at a particular preprogrammed address. The second main section contains two DACs which are connected to the address bus. Their outputs are converted by two operational amplifiers and fed to test points.

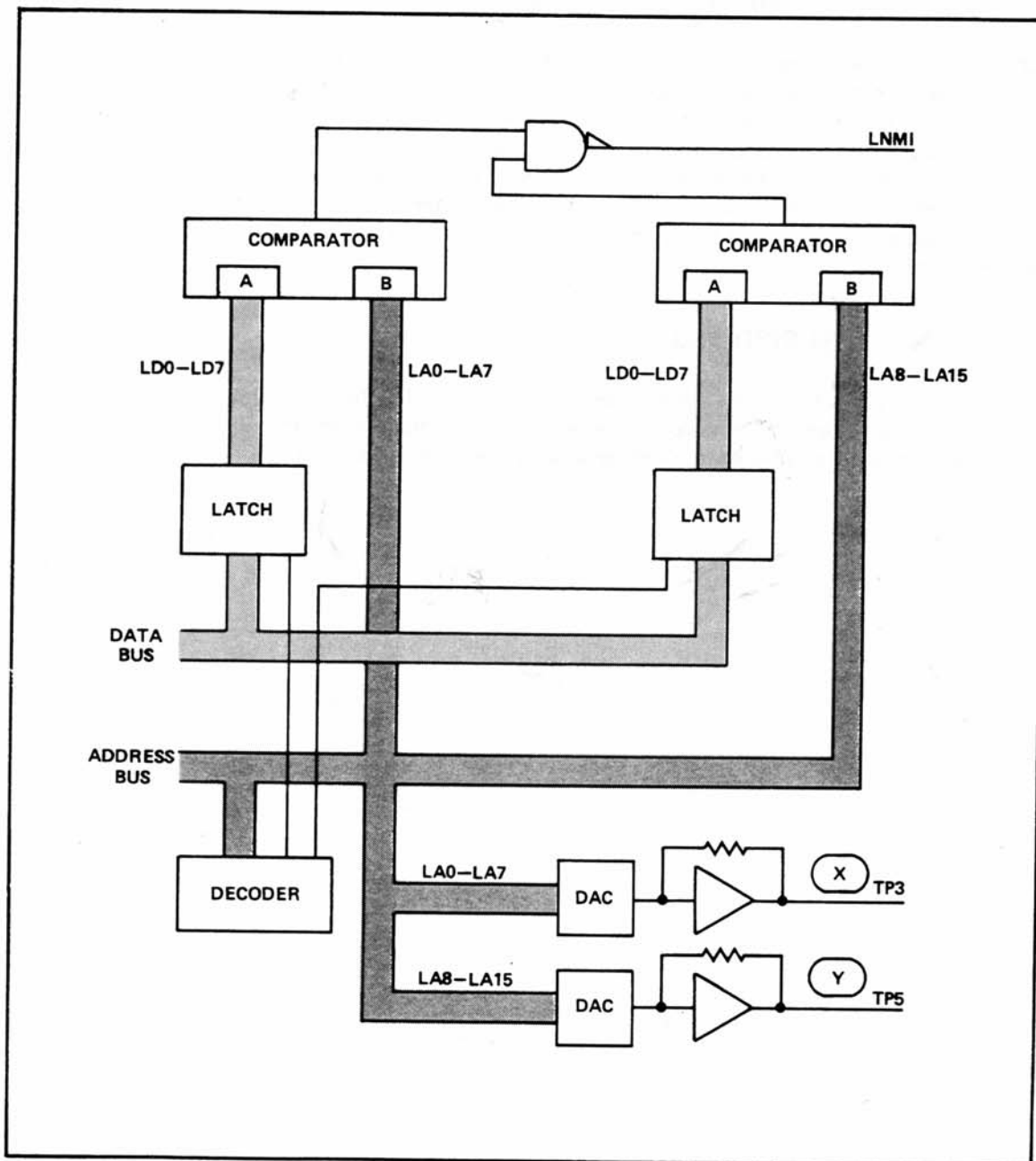

Figure 8-4. 05370-60014 Block Diagram

8-31. DETAILED THEORY (05370-60014). Integrated circuits U16, U13, and U17 form three Set-Reset latches with inverted outputs and are used to debounce the NMI, IRQ, and RES switches. These outputs go directly to the control lines on the instrument's internal bus. U15A, U9A, and U6 form the decode logic which decodes the address of the 05370-60014 assembly. Their outputs enable the breakpoint decoder U3. Three outputs of U3 are being used. U3(15) enables registers (latches) U5 and U4 to latch the information on the D (pins 4, 13, 5, 12) inputs. The Q outputs (pins 2,15,7,10) connect to U2 and U1 comparators, where they are compared to the low order address lines (LA0 through LA7). U3(14) enables registers U10 and U11 to latch the information on the D (pins 4,13,5,12) inputs. The Q outputs (pins 2,15,7,10) connect to U8 and U7 comparators, where they are compared to the high order address lines (LA8 through LA15). The final output of U3 (pin 13) enables register U12 to latch the data from the lower order data lines (LD0 through LD3). U12 Q outputs (2, 15) select on which cycle (read or write) the breakpoint occurs. U12(2) high is write cycle and U12(15) high is read cycle. U15C(8) is the NANDing of VMA and clock ϕ_2 , and used for the strobe input on the HP 5004A Signature Analyzer.

8-32. The DAC section consists mainly of U18, U19, U20, U21, and CR1. The +15V supply is fed through current limiting resistors R11 and R10 to voltage reference CR1. R5 and R8 set the current which enters U18 and U19. Resistors R13, R12, and R15 form a divider which produces 5.12 V at TP4 used to adjust an oscilloscope for mapping. U19 is connected to the lower order address lines and U18 is connected to the higher order address lines. The outputs are connected to op-amps U21 and U20, respectively. The op-amps translate the DAC current mode output to a voltage mode. These voltages are used to drive the X and Y axis of an oscilloscope to MAP the microprocessor's program address.

8-33. SIGNAL DESCRIPTIONS

8-34. *Table 8-3* is a list of the signals used in the 5370B. The list is in alphabetical order and includes the mnemonics for cross-reference with the schematic diagrams. A description of the function of each signal and the source and destination are included in the table.

Table 8-3. Signal Descriptions

MNEMONIC	FROM	TO	LOGIC	DESCRIPTION
DAC CTL	XA16B(3)	XA18A($\bar{5}$)	TTL	DAC Control — This line is decoded on the A16 assembly. It is the write clock for the DAC control registers. It latches the data to be used to control the start and stop trigger levels.
DAC STAT	XA16B(5)	XA18A($\bar{7}$)	TTL	DAC Status — This signal is decoded on the A16 assembly. It is the read clock for the DAC Status register on the A18 assembly.
DBE	XA9B($\bar{4}$)	Instrument Bus	TTL	Data Bus Enable — This input is the control input of the microprocessor's data bus. The data bus is enabled when this input is high. When the input signal is low, the data bus is a high impedance.
ERMD	XA22(2)	XA17A(3)	ECL	ECL Armed — This is the status line for the Arm flip-flop. It also passes through a TTL translator and lights the ARM LED in the front panel.
EXT TRIG	A22J3(11)	A23J4	TTL	External Trigger — This is a signal used to light the front panel external trigger LED.
HARMEN	A16J1	A22J1	ECL	High Arm Enable — This signal enables the A22 arming assembly to make a measurement.
H DAC	Rear Panel	A15J1(4)	TTL	High Data Accept — Signal which, when high, indicates to the transmitting device that data has been accepted by the receiver.
HEXT	A1/A2	XA17B(18)	TTL	high External — This line is connected to the rear panel INT/EXT Time Base switch. It tells the microprocessor whether the machine is in Internal (high) or External (low) time base.
HMNRM	A16J1	A22J1(9)	TTL	High Manual Arm — Signal is HIGH when machine is in manual arm or in +T.I. only without external arm, where the 5370B ARMS itself.
HN3B0→B2	A22J1	A16J1(6,7,8)	ECL	High N0 bit) through B2 — These are three of the four low-order bits of the event counter.
HN3B3	XA17B(2)	XA16B(7)	TTL	High N0 bit 3 — This is the fourth low order bit of the event counter and the clock to the higher order bits.
HN3RST	A16J1(5)	A22J1(5)	TTL	High N0 Reset — A high on this line resets the Event (N0) counters.

Table 8-3. Signal Descriptions (Continued)

MNEMONIC	FROM	TO	LOGIC	DESCRIPTION
HPTOGL/ CHECK	A161(2)	A22J1(2)	TTL	High Toggle/Check — HPTOGL is a decode of the front panel Period Complement push-button. This pulsed signal toggles the machine's arming from one channel to the other. When this signal is a level (high) instead of a pulse, the input multiplexers on the A22 assembly select the 10 MHz calibration signal.
HRFD	Rear Panel	A15J1(3)	TTL	High Ready for Data — This signal, when high, indicates to the Hp-IB that the listening device is ready to receive data.
HRMCT3	A16J1(13)	A22J1(13)	ECL	High Arm Control 3 — This signal controls the slope of the external arm signal to be used.
HRMD	A22J3(10)	A23J4(10)	TTL	High Armed — This signal is sent to the front panel to light the ARM LED indicator when the instrument is armed.
HRMEN	A16J1(9)	A22J1(9)	TTL	High Arm Enable — When HRMEN is high, it enables the Arm.
HRMT Slope	XA18A($\bar{1}$)	XA22A(1)	TTL	High Remote Slope — This signal, when high, disables the local slope control and enables the remote slope control.
H RUN	XA9A(15)	Instrument Bus	TTL	High Run — The H RUN signal is the inverted Bus Available signal. The H RUN signal will normally be in the high state. When activated, it will go to the low state indicating that the microprocessor has stopped and that the address bus is available.
HSET1	A16J1(12)	A22J1(12)	TTL	High Set 1,2 — These two signals set or reset a flip-flop to determine whether the Start or Stop channel signal will be used to Arm the 5370B.
HSET2	A16J1(11)	A22J1(11)	TTL	
HSTART	A22J3(8)	A23J4(8)	TTL	High Start — This line is used to light the START and STOP annunciator LEDs in the front panel display. A high lights the START and a low lights the STOP.
HSTASW	A16J1(16)	A22J1(16)	ECL	High Start Switch — Used to control the input signal multiplexer for the START channel. A high causes the START channel to be gated through the START multiplexer. A low causes the STOP channel to be gated through the START multiplexer.
HSTD	A16J1(10)	A22J1(10)	TTL	High Standard — When HSTD is high, it disables the automatic phase detector on the A22 board.

Table 8-3. Signal Descriptions

MNEMONIC	FROM	TO	LOGIC	DESCRIPTION
HSTOSW	A16J1(15)	A22J1(15)	ECL	High Stop Switch — Used to control the input signal multiplexer for the STOP channel. A high causes the STOP channel to be gated through the STOP multiplexer. A low causes START channel to be gated through the STOP multiplexer.
LA0 through LA15	XA9A($\overline{3}$ through $\overline{18}$)	Instrument Bus	TTL	Low Address Bus — The address bus is a unidirectional, 16-line bus from the A9 assembly used to address all memory (ROM and RAM) and peripheral devices.
LARMCT2	A16J1(1)	A22J1(1)	TTL	Low Arm Control 2 — Signal used to control whether the Arm comes from either the START or STOP channel, or whether it comes from the manual or external input. When the signal is low, the ARM comes from the START or STOP channel. With the signal high, the ARM comes from the manual or external input.
LARMRST	A16J1(17)	A22J1(17)	TTL	Low Arm Reset — A low pulse signal which is the master reset for the arming assembly.
LATN	Rear Panel	A15J1(7)	TTL	Low Attention — Active low signal which places the HP-IB in the "Command Mode".
LDAV	Rear Panel	A15J1(2)	TTL	Low Data Valid — Active low signal which, when true (low), indicates that data on the DIO lines is stable and available to be accepted by the receiving device.
LDIO1 through LDIO8	Rear Panel	A15J2 Pins (5 through 12)	TTL	Low Data Input/Output — Mnemonic abbreviation referring to the eight data lines of the HP-IB. These lines are active low.
LD0 through LD7	XA9A (3 through 10)	Instrument Bus	TTL	Low Data Bus — The data bus is a bi-directional, eight-line bus used for transferring data to and from the memory and peripheral devices. The bus is active low. All devices on the bus are three-state.
LEOI	Rear Panel	A15J1(1)	TTL	Low End or Identify — This signal (active low) is used to indicate the end of a multiple byte message on the Bus. It is also used in parallel polling.
LGATEN	A16J1(4)	A22J1(4)	TTL	Low Gate Enable — Signal used for external hold-off or for measuring frequency with a gate time. When this signal is low, the A22 assembly is enabled for external hold-off or a gate time mode in frequency operation.

Table 8-3. Signal Descriptions (Continued)

MNEMONIC	FROM	TO	LOGIC	DESCRIPTION
LHLDEN	A16J1(14)	A22J1(14)	TTL	Low Hold-Off Enable — Signal selects whether or not the machine is in \pm T.I. or +T.I. only. With the signal low, the 5370B is in +T.I. only.
LHLT	Instrument Bus	XA9B($\bar{6}$)	TTL	Low Halt — This level-sensitive input is normally in the high state. In low state, all activity in the microprocessor is halted.
LIFC	Rear Panel	A15J1(5)	TTL	Low Interface Clear — When LIFC is set (low) all talkers and listeners on the HP-IB are unaddressed, and controllers go to the inactive state. Only the system controller can activate this line.
LINZ	(Troubleshooting AID)	XA9B($\bar{3}$)	TTL	Low Initialize — This input is provided as a troubleshooting aid and is used to reset the microprocessor clock state machine.
LIRQ	Instrument Bus	XA9A(13)	TTL	Low Interrupt Request — LIRQ is a normally-high, level-sensitive input of the microprocessor. When LIRQ goes low, the microprocessor is requested to do an interrupt sequence. At that time, if the interrupt mask bit in the Condition Code Register is not set, the machine will begin an interrupt sequence.
LNMI	Instrument Bus	XA9A(14)	TTL	Low Non-Maskable Interrupt — A negative-going edge on this input requests a nonmask interrupt sequence be generated in the microprocessor. As with LIRQ, the microprocessor completes the current instruction before recognizing the LNMI signal. However, the interrupt mask bit in the Condition Code Register has no effect on LNMI.
LOCK FIX	XA18A(10, $\bar{10}$)	XA19A($\bar{15}$) XA20A($\bar{15}$)	NA	Lock Fix — This signal is used to force the A19/A20 Interpolator assemblies to phase-lock with the reference. This signal is active upon power-up and when the phase-locked loop is out of lock.
LORST	XA16B($\bar{6}$)	XA17A($\bar{9}$)	TTL	Low Out-of-Lock Reset — This line is used to reset the Out-of-Lock flip-flop (flag) on the A17 assembly.

Table 8-3. Signal Descriptions (Continued)

MNEMONIC	FROM	TO	LOGIC	DESCRIPTION
LOOL	XA21A($\overline{18}$)	XA17B(1)	TTL	Low Out-of-Lock — This is the out-of-lock line from the A21 assembly. When it goes low, it sets the out-of-lock flip-flop on the A17 board. The flip-flop then lights the out-of-lock LED on the A17 board and sets the out-of-lock status bit for the microprocessor.
LOVEN	XA2A($\overline{1}$)	XA17A($\overline{18}$)	TTL	Low Oven — This line drives (through the microprocessor) the oven indicator on the front panel. When the line is low, the front panel indicator lights and indicates that the oscillator oven is below operating temperature (cold). This is the normal case when the instrument is first connected to the line supply.
LPCRST	XA16B($\overline{4}$)	XA17A($\overline{7}$)	ECL	Low Pulse Counter Reset — A Low Pulse on this line resets all the counters on the A17 assembly.
LPOLRST	XA16B($\overline{6}$)	XA17A($\overline{9}$)	ECL	Low Pulse Out-of-Lock Reset — This line is a power-up reset pulse used to reset the Out-of-Lock flip-flop during power on.
LPORST	XA16B($\overline{5}$)	XA17A($\overline{8}$)	ECL	Low Pulse Overrange Reset — This is the reset for the overrange flip-flop (flag) on the A17 assembly.
LPOROST	XA16B($\overline{5}$)	XA17A($\overline{8}$)	ECL	Low Pulse Overrange NO Reset — The NO counter flag is reset when overrange occurs. Overrange is the condition when bit 17 of the NO count chain becomes active. At this point, the flat is reset. The number of times the counter overranges is kept in software.
L PROC	XA18B(5)	XA17A($\overline{5}$)	ECL	Low Process — This signal is a status signal for the microprocessor. When low, it indicates to the microprocessor that the measurement has been completed.
LREN	Rear Panel	A15J1(16)	TTL	Low Remote Enable — This line is used to enable Bus compatible instruments to respond to commands from the controller or another talker. It can be issued only by the system controller.
LRMMASK	XA16B(9)	XA11B($\overline{5}$)	TTL	Low Remote Mask — This line is active in remote operation. It masks all the front panel push-buttons with the exception of the Local-Remote switch.
LRST	XA9A(18)	(Troubleshooting Aid)	TTL	Low Reset — This is the main reset for the 5370B. It is used to initialize the microprocessor.
L(R/W)	XA9A(11)	Instrument Bus	TTL	Low Read/Write — (L(R/W) is the inverted R/W signal from the microprocessor. This output tells the memory devices if the microprocessor is in a Read (low) or a Write (high) state.

Table 8-3. Signal Descriptions (Continued)

MNEMONIC	FROM	TO	LOGIC	DESCRIPTION
LSRQ	Rear Panel	A15J1(6)	TTL	Low Service Request — This signal line is set true (low) when the 5370B requests service from the HP-IB controller.
LVMA	XA92A(2)	Instrument Bus	TTL	Low Valid Memory Address — This is an active low signal which when low, indicates to the peripheral devices that there is a valid address on the address bus.
MAN ARM	XA1B($\bar{3}$)	XA16B($\bar{8}$)	TTL	Manual Arm — This line is a decode from the front panel manual arm push-button. When this line goes low, an interrupt is generated and the microprocessor puts the machine in the manual arm mode.
$\phi 2$	XA9B($\bar{5}$)	Instrument Bus	TTL	Phase Two — The second phase of the two-phase clock which runs the microprocessor. The amplitude runs between and common.
SIGN	XA18B($\bar{4}$)	XA17B(4)	ECL	Sign — This line is a status line for the microprocessor. It indicates the sign of N0. When this line is high, the sign of N0 is positive.
START DAC	XA16B(1)	XA18A($\bar{3}$)	TTL	Start DAC — This line is decoded on the A16 Assembly. It is the write clock for the Start DAC registers. It latches the data to be used by the Start D-to-A converter.
START TRG	A22J3(9)	A23J4(9)	TTL	Start Trigger — This is a signal used to light the front panel start channel trigger LED.
STOP DAC	XA18B(2)	XA18A($\bar{4}$)	TTL	Stop DAC — This signal is decoded on the A16 assembly. It is the write clock for the Stop DAC registers. It latches the data to be used by the Stop D-to-A converter.
STOP TRG	A22J3(7)	A23J4(7)	TTL	Stop Trigger — This is a signal used to light the front panel stop channel trigger LED.
S RATE	XA16B(6)	XA22A(16)	NA	Sample Rate — This line goes to the sample pot on the front panel.
TRGLVLA TRGLVLB	XA18A(16) XA18A(17)	XA22A($\bar{2}$) XA22A($\bar{3}$)	NA	Trigger Levels A and B — These signals are from the A18 DACs. They are passed through a filter on the A22 assembly and sent to the A4 board. These signals are then used as the remote trigger levels.

8-35. CABLES

8-36. Table 8-4 lists the 18 cables used in the 5370B. They are listed in numerical order with a brief description and destination. Also refer to Figure 8-15, Top Interval View.

Table 8-4. Cable Destinations

REF. DESIG.	HP PART NO.	DESCRIPTION	FROM	TO
W1	05370-60401	Rear Panel Power Transistor Wire Harness	Rear Panel Q1 through Q4	A1 Motherboard
W2	05370-60402	Front Panel STBY/ON SW1 Wire Harness	Front Panel STBY/ON SW1	A1 Motherboard
W3	05370-60403	Coax Cable	A22J5	Rear Panel J4
W4	05370-60404	Coax Cable	Front Panel J1	A22J4
W5	05370-60405	Rear Panel SW3 Wire Harness	Rear Panel SW3	A1J4
W6	05370-60406	Coax Cable	A1J2 (A8(4))	Rear Panel J7
W7	05370-60407	Coax Cable	A1J1	A2J2
W8	05370-60408	Coax Cable	Rear Panel J6	Rear Panel SW3(1)
W9	05370-60409	Coax Cable	A1J3	A2J3
W10	05370-60410	Coax Cable	A22J6	Rear Panel J5
W11	8120-2463	Ribbon Cable, 26 AWG 18 Conductor	A16J1	A22J1
W12	8120-2462	Ribbon Cable, 26 AWG 16 Conductor	A5J1	A15J1
W13	8120-2462	Ribbon Cable, 26 AWG 16 Conductor	A5J2	A15J2
W14	8120-2462	Ribbon Cable, 26 AWG 16 Conductor	A11J1	A23J1
W15	8120-2462	Ribbon Cable, 26 AWG 16 Conductor	A11J2	A23J2
W16	8120-2462	Ribbon Cable, 26 AWG 16 Conductor	A11J3	A23J3
W17	8120-2462	Ribbon Cable, 26 AWG 16 Conductor	A22J3	A23J4
W18	8120-1378	Power Cord	---	Rear Panel Line Module (A24)

8-37. LOGIC SYMBOLS

8-38. Logic symbols used in this manual conform to the American National Standard publication *IEEE Standard Graphic Symbols for Logic Functions, ANSI/IEEE Std. 91-1984*. This standard supersedes MIL-STD-806B. Another useful reference source is *The TTL Data Book, "Explanation of New Logic Symbols"* by F.A. Mann (Texas Instruments Incorporated).

Paragraphs 8-39 thru 8-59 have been deleted.

8-60. REPLACING FRONT PANEL LIGHTS

8-61. For the purpose of replacement, the front panel lights can be divided into three categories: 1) seven-segment display and annunciator LEDs; 2) push-button switch and clock loss LEDs; and 3) trigger light LEDs. Replacement procedures are given under separate headings for each type.

8-62. Seven-Segment Display and Annunciator LEDs

8-63. To replace an LED of this type, first remove the red display window by sliding the three plastic slide clamps to the left. The window is now free to remove. To replace any of the seven segment displays, insert an IC puller over the top and bottom of the LED display and pull out.

8-64. To replace an annunciator LED, first remove the top cover and the red display window. Remove the frosted plastic sheet that covers the annunciator block. Gently place the tips of a pair of needle-nose pliers over the LED while applying a soldering iron to the solder connections on the rear of the A23 Display/Push-button Switch board. Remove the LED. When replacing the new LED, be sure to insert the cathode (the shorter lead) into the pc hole with the square pad.

8-65. Push-button Switch and Clock Loss LEDs

8-66. There are two methods of replacing these LEDs. The first method involves removing the front panel and using heat-shrink tubing to extract the LED. The second method requires the A23 Display/Push-button Switch board be removed from the instrument. Neither of these procedures is overly difficult or time consuming; however, Method 1 is preferred if the heat-shrink tubing is available. See paragraph 8-69 under Method 1 for clock loss LED replacement.

8-67. **METHOD 1.** To replace a push-button switch LED, first remove the front panel by removing the hardware associated with the three input jacks, the three LEVEL controls, and the MAN RATE control. Also remove nut from backside of A23 Display Push-button Switch board, near left side of the instrument. The push-button can now be removed using an IC puller.

NOTE

The push buttons can be removed with the front panel on if the IC puller is modified by breaking it in half and filing down both sides of the blade's wide portion just before it tapers down to the narrow tip area. Insert the tip between push-button and front panel and place tip of puller under backside of push-button. Hold opposite side of push-button with finger and pull forward.

8-68. Once the push-button is removed, replace heatshrink tubing that is about 1/8" ID (HP P/N 0890-0983) over the replacement (new) LED and use a heat gun to shrink tubing around LED. Pull tubing off of LED and insert through the middle of the front panel switch and securely over the faulty LED. Heat the LED solder connection of rear side of the A23 board and remove LED. Use a toothpick to clear solder holes. Place tubing over new LED and insert into place. Short lead of LED (cathode) goes into hole with square pad. Solder in place.

8-69. The Clock Loss LED can also be replaced using the heat-shrink tubing method as outlined above. The front panel need not be removed. If tubing is not available, use Method 2. Be sure to retain the spacing insulator when installing the new LED.

8-70. **METHOD 2.** This method requires removing the A23 Display/Push-button Switch board. The procedure is outlined under Push-button Switch Removal. Once the board is removed and disassembled, remove the specific switch for access to the LED and remove the LED in the normal manner.

8-71. Trigger Light LEDs

8-72. Remove the front panel by removing the hardware associated with the three input jacks, the three LEVEL pots, and the MAN RATE control. Also, remove nut from back side of A23 Display/Push-button Switch board, near left side of the instrument. Gently hold the LED with a pair of needle-nose pliers while heating the solder connections on the rear side of A23. Remove the LED. At this point, the large plastic spacer will come free. Tilt the counter and shake until spacer falls out. This part was used when the board was loaded prior to wave soldering and is no longer required. The new LED can be properly positioned by hand during replacement.

8-73. PUSH-BUTTON SWITCH REMOVAL

8-74. The following procedure outlines the steps necessary to disassemble the instrument for the removal of the push-button switches.

1. Remove the top and bottom covers.
2. Remove right and left side covers (2 screws each).
3. Remove trim strip along top of front panel frame.
4. Remove four screws from top of front panel frame.
5. Disconnect the four ribbon cables from the A23 board.
6. Disconnect the three coax cables and two ribbon cables on A22 Arming board (see A22 Arming board removal in Section V).
7. Remove the A22 Arming board and A4 Interconnect board.
8. Remove the two screws that hold each of the four side struts to the front panel frame.
9. Slide the front panel assembly forward and free of the instrument. (The power switch remains in place.)
10. Place the assembly face down on the table; and using a pair of long-nose pliers, removal all retainer clips holding the A23 board in place.
11. Remove the nut on the left side of the A23 board.
12. Leave the assembly face down and lift the A23 board straight up. The front panel has spacers on the studs, and they will fall out if this is turned upside down.
13. Cut away that part of the red switch stud that has been heat staked to the back side of the board.
14. Remove faulty switch and insert new switch into place.
15. Using a soldering iron with a flat-bladed tip, heat-stake the new switch to the back side of the board. Use extreme care when installing the new switch, making sure that the switch is secured tightly against the pc board before heat-staking. When applying heat, melt the plastic stud down just enough to form a mushroom-shaped rivet bond. Be careful to (1) not melt too much plastic away, thus weakening the bond, or (2) not melt enough plastic away, thus leaving a space between the rivet and the pc board, allowing the switch to move.

8-75. BLOCK DIAGRAM THEORY

8-76. Introduction

8-77. The HP 5370B is a Time Interval counter using the digital interpolating technique (refer to *Figure 8-21*). For a typical Time interval measurement, the start and stop signals enter the input assembly, pass through the arming assembly, and enter the Start and Stop interpolator assemblies. Pulse bursts from these two interpolators plus a third coincident burst (N0) go into the count chain assembly. Events are counted in the arming and arming interface assembly. With these four counts, Time Interval, Frequency, and Period measurements can be mathematically derived using the following equation:

$$\begin{aligned}
 TI &= 5 \left(\frac{257}{256} (N1-N2) + N0 \right) \text{ nanoseconds} \\
 \text{FREQ} &= \frac{\text{EVENTS}}{TI} \\
 \text{PERIOD} &= \frac{TI}{\text{EVENTS}}
 \end{aligned}$$

where TI is the Time Interval in nanoseconds, N0 is a 200 MHz reference count between coincidences, N1 is the Start Interpolator count, N2 is the Stop Interpolator count and events is the number of Stop channel input pulses (**events** is used for frequency and period when used with a gate time measurement). An explanation of the equation and the N0, N1, and N2 counts follows in the next paragraphs.

8-78. The 5370B uses a dual vernier interpolation technique for resolution improvement beyond the 5 ns uncertainty imposed by a 200 MHz basic clock. Two vernier oscillators, each started by the START and STOP pulses, generate bursts of N1 and N2, respectively, each burst being terminated by the coincidence signals START COINC and STOP COINC. These coincidence signals are used to gate the main 200 MHz clock to generate a third burst N0. The frequency of the two vernier oscillators are the same, namely 199.22179 MHz (period \approx 5.02 ns) which is synthesized from the 200 MHz clock through phase-locking technique by the ratio 256:257.

8-79. The burst N1 is proportional to the time between START signal and the clock pulse arriving after it. In the same manner, N2 is proportional to the time between STOP signal and the clock pulse arriving after it. The resolution of these time intervals is given by 5/256 ns or around 20 ps which is the period difference between main and vernier clocks. The time interval is given by

$$TI = 5 \frac{257}{256} (N1-N2) + N0 \text{ ns}$$

In time interval holdoff, or frequency/period mode, the number of events held off is measured in addition to the time interval of occurrence. Frequency and Period are given by:

$$\begin{aligned}
 \text{FREQ} &= \frac{\text{EVENTS}}{TI} \\
 \text{PERIOD} &= \frac{TI}{\text{EVENTS}}
 \end{aligned}$$

The 200 MHz burst N0 occurs between the ending of N1 and the ending of N2. It is a signed number and is + when N1 finishes before N2 and negative vice versa. No restriction is made on the order of occurrences of the START and STOP pulses using the above formula for TI computation.

8-80. Interpolating Technique

8-81. For simplicity, the Interpolating Technique is explained assuming a positive time interval measurement (start pulse arrives before the stop pulse). The explanation in the following paragraphs refer to *Figure 8-5*.

8-82. In +TI ONLY the 5370B is armed internally by the microprocessor. When the start pulse first arrives, the start interpolator VCO momentarily stops oscillation for a duration determined by a fixed delay line. Oscillating again starts in phase with the trailing edge of the delay output. This establishes a definite phase relationship needed for comparison to the reference oscillator. The output of the start interpolator oscillator (VCO) is used in two places. First, it goes to the Count Chain Assembly where the pulses are counted as N1. And second, it is mixed with the 200 MHz reference on the Start Interpolator assembly by a D-type flip-flop. When a positive edge of the start oscillator occurs at the same time as a positive edge of the 200 MHz reference, the mixer sends a positive transition to the DAC/N0 assembly. This signal is called START COINCIDENCE, and it starts the accumulation of the 200 MHz reference count (N0). This coincidence pulse also gates off the output of the START Interpolator oscillator (N1). N1 has not been accumulated and N0 has started to accumulate.

8-83. The same thing happens with the stop interpolator. The stop pulse arrives and momentarily stops the stop interpolator VCO from oscillating. The output of the stop interpolator starts again in phase with the trailing edge of the delay output. The output of the stop VCO is used in two places. First, it goes to the Count Chain Assembly where the pulses are counted as N2. And second, it is mixed with the 200 MHz reference on the Stop interpolator assembly by a D-type flip-flop. When a positive edge of the stop VCO occurs at the same time as a positive edge of the 200 MHz reference, the mixer sends a positive transition to the DAC/N0 assembly. This signal is called STOP COINCIDENCE, and it stops the accumulation of the 200 MHz reference count (N0). This coincidence pulse gates off the output of the stop interpolator VCO (N2) and also sets the LPROC line low, signaling the microprocessor that the measurement has been completed.

8-84. The Equation

8-85. The microprocessor now has the three variables N0, N1, and N2 to process the data into a meaningful result. N2 is subtracted from N1. This result is the net time error in terms of ≈ 5.02 nanosecond periods. This cannot be added to N0 (5.00 nanosecond periods) without a common denominator. To produce a common denominator, the N1-N2 is multiplied by $\frac{257}{256}$. This factor ($\frac{257}{256}$) is the exact ratio between 5.00 nanoseconds and 5.0195763 (≈ 5.02) nanoseconds. Now the two can be added to produce the number of 5.00 nanosecond periods accumulated between the start and stop input pulses. To turn this number of counts into a unit of time, it is multiplied by 5×10^{-9} , since each count represents one period of the oscillator. This result, which is the time interval in seconds, is then displayed and the sequence begins again. The N0 count may be either positive or negative in value, because even though the start pulse arrives before the stop pulse, the stop coincidence may occur before the start coincidence. For this reason, the sign of N0 is also fed to the microprocessor.

8-86. Typical Instrument Operation

8-87. On power-up, the microprocessor checks the ROMs, RAMs, PLLs, lights the front panel indicators and all segments of all readouts. It then sets the 5370B in TI, SAMPLE SIZE 1, MEAN, +TI ONLY, and arms the counter. The 5370B remains in a wait loop until a start pulse arrives.

8-88. With an input signal, and for SAMPLE SIZE of 1; N0, N1, and N2 counts accumulate. When the accumulation is complete, the DAC/N0 assembly signals the microprocessor (LPROC) to process the data and display the information requested by the keyboard. The microprocessor periodically examines the keyboard for any change in key selection.

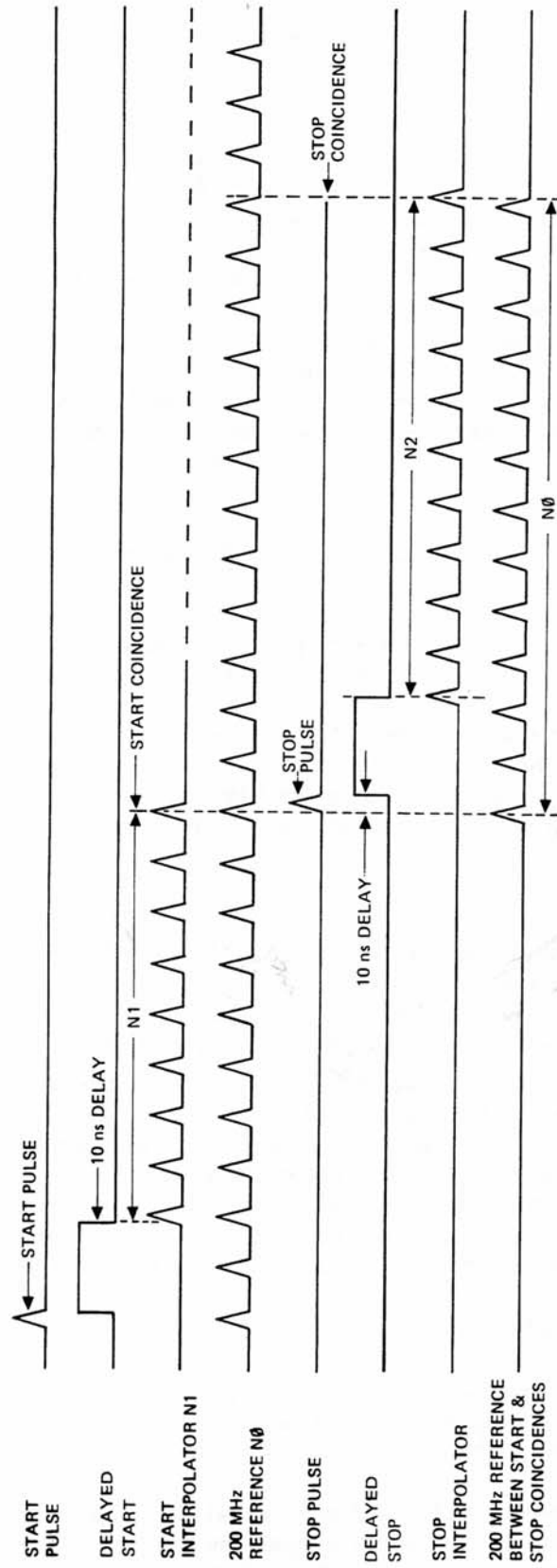

Figure 8-5. Interpolator Timing Diagram

8-89. For a SAMPLE SIZE >1, the microprocessor does not send data to the display until all samples are complete. After each sample, the microprocessor performs an intermediate computation, which takes approximately 330 microseconds, and stores the data into RAM. Because the LPROC goes low for each intermediate computation, the microprocessor can count these clocks for comparison to the number of samples programmed by the keyboard. The microprocessor ends the measurement when the sample size is complete and performs the final computation. The microprocessor then writes to the display RAMs the information requested by the keyboard.

8-90. A1, A6 Power Supply Motherboard/Power Supply Control Assembly

8-91. The Power Supply Motherboard/Power Supply Control Assembly (A1, A6) supplies all dc power for the instrument, except for the Quartz Crystal oven Oscillator. The ac line voltage enters through the Power Module (correct selection of line input voltage determined by Power Module card) to the power transformer primary windings and to the instrument fan. The voltages from the secondaries of the power transformer are rectified, filtered, and sent directly to the Power Supply Control Assembly (A6). The four unregulated voltages of +10V, +20V, -20V, and -10V are fused at the A6 board inputs. A separate transformer secondary winding supplies power to the Quartz Crystal oven Oscillator Power Supply (A7).

8-92. When the front panel STBY-ON switch is set to ON, ac power is sent to the fan, and voltage is applied to the Voltage Reference IC, enabling conversion of the four unregulated voltages to regulated voltages of +5V, +15V, -15V, and -5.2V for distribution throughout the instrument. These voltages are supplied by four separate linear series-pass regulators which are referenced to a single +10.0V precision reference IC (A6U5).

8-93. A3 and A4 Input Assemblies

8-94. The input configuration consists of an Input Amplifier Assembly (A3) and an Interconnect Assembly (A4). These two assemblies contain the controls which determine the type of coupling, the input impedance, the trigger slope and the trigger level. The trigger level and the slope selection can be selected either manually by front panel controls or remotely by HP-IB. The START and STOP signals are amplified and conditioned and then sent to the ARMING assembly (A22) at the rate at which they are input to the machine.

8-95. A5 HP-IB Connector Assembly

8-96. The A5 Assembly provides the interconnection between A15 and the interface bus. Switch S1 is used to select the address code for the instrument.

8-97. A8 Reference frequency Buffer Assembly

8-98. The Reference Frequency Buffer Assembly (A8) receives 10 MHz from either of two sources. The first source is the internal crystal time base. The second source is the EXTERNAL frequency input (5 or 10 MHz) from the rear panel connector J6. Whichever 10 MHz signal is selected is shaped and sent to four buffers and a signal monitor. The monitor is an LED and a one-shot multivibrator triggered by the 10 MHz signal. When the LED indicator is on, the selected source signal is present.

8-99. A9 Processor Assembly

8-100. The Processor Assembly (A9) contains the microprocessor, clock logic and driver circuits, RAM, RAM Address Decode logic, ROM, and Address and Data Buffers. The Address Bus contains 16 lines which can address up to 65K locations. They are one direction (out only). The data bus contains 8 lines. These are bi-directional (Input and Output) to the A9 Assembly.

8-101. The third bus is the control bus. The lines are mainly microprocessor inputs with the exception of three. The R/W (Read/Write) line is an output to the RAMs. The VMA (Valid Memory Address) line is used for decoding. And the BA (Bus Available) line used to tell assemblies on the Address Bus, the bus is not being used by the microprocessor. The remaining control lines enable the microprocessor to keep track of the status of the rest of the machine. For example, these lines enable the machine to use the HP-IB and lets the microprocessor know when a key is pressed or when a measurement has been completed. The RAMs are used to store data such as which key is active or the results of previous measurements. The ROM contains all the microprocessor operating instructions.

8-102. The 10 MHz is present from the A8 Frequency Buffer Assembly to run the Microprocessor Clock State Machine, which generates all necessary processor clocks.

8-103. A11 Display Interface Assembly

8-104. The Display Interface Assembly (A11) allows the microprocessor (A9) to communicate with the display and keyboard. The A11 Assembly is connected directly to the machine's internal processor bus. All logic for decoding and driving, and the latch and RAM for the key data and display data, respectively, are located on the A11 assembly. The RAMs store the previous measurement result during the current measurement cycle. This data is sent to the Display/Control Panel Assembly (A23).

8-105. A15 HP-IB Interface Logic Assembly

8-106. The HP-IB Interface Logic Assembly (A15) serves as an interface between the 5370B and an external controller via the HP interface Bus. The A15 assembly consists of seven interface registers (which are used by the microprocessor for interpreting commands and data, sending status, sending data, interpreting interrupts, etc.), two command decoding ROMs, and source and acceptor handshake circuitry.

8-107. A16 Arming Interface Assembly

8-108. The Arming Interface Assembly (A16) contains the Address Decoder, Input/Output Registers, and Selector/Multiplexers needed for control interface between the Arming Assembly (A22), DAC/N0 Assembly (A18), and the Processor Assembly (A9).

8-109. A17 Count Chain Assembly

8-110. The Count Chain Assembly (A17) accumulates (counts) the N1 signal (Start interpolator VCO output between the start input pulse and the VCO and 200 MHz reference coincidence), the N2 count (Stop Interpolator VCO output between the stop input pulse and the VCO and 200 MHz reference coincidence), and N0 (200 MHz reference burst between N1 and N2). Other inputs to the A17 Assembly are LPROC from the DAC/N0 Logic Assembly (A18) which indicates both interpolators (A19, A20) have completed a measurement cycle; and the Sign input also from the DAC/N0 Logic Assembly, indicating a start coincidence first (sign is High) or stop coincidence first (sign is Low)

8-111. N1 and N2 counts enter a subtractor where the result is $N1-N2$. This count then enters a shift and add block where it is effectively multiplied by 257 giving the result $257 \bullet (N1-N2)$. This number along with N0 and the sign enter a multiplexer where it is then output to the processor (A9) via the data bus.

8-112. A18 DAC/N0 Logic Assembly

8-113. Between the time of the Start Coincidence and the Stop Coincidence, the 200 MHz reference frequency, from the 200 MHz Multiplier Assembly (A21), is gated to the Count Chain Assembly by the A18 assembly. This 200 MHz burst is sent to the Count Chain Assembly as the N0 count. The DAC/N0 Logic Assembly also keeps track of which coincidence occurred first. This allows the DAC/N0 Logic Assembly to assign a positive (Start Coincidence first) or a negative (Stop Coincidence first) sign to the Time Interval.

8-114. The DAC/N0 Assembly tells the processor, via the Count Chain board (A17), when the measurement has been completed (both Start and Stop Coincidences occurred). The DAC/N0 Logic Assembly contains the logic which allows the START and STOP input LEVEL control to be program set remotely via the HP-IB. It also contains the logic which allows the input slopes to be remotely programmed.

8-115. The Lock Fix output from the DAC/N0 Logic Assembly to the interpolator Assemblies (A19, A20) is active on power-up. When active, it gives the phase detectors on the Interpolators an indication that the VCO frequency is high. As a result, the VCO frequency is pulled low. When Lock Fix goes inactive, it releases the phase detectors which then lock the VCOs to the correct frequency. This is performed to insure that the VCOs lock to the correct sideband of the 200 MHz reference when the instrument is first turned on.

8-116. A19 and A20 Interpolator Assemblies

8-117. The two interpolators (A19 Start Interpolator, A20 Stop Interpolator) are exactly the same. For this reason, only the START Interpolator will be discussed. The Interpolators are basically phase changeable, oscillation interruptible, phase-lock-loop oscillators.

8-118. The START and STOP output triggers from the Arming Assembly (A22) are input to the START (A19) and STOP (A20) Interpolators, respectively. When an input trigger arrives, it goes to two delayed one-shot flip-flops and to the enable of the coincidence output gate. The VCO is inhibited from oscillating for about 10 nanoseconds after the arrival of the input trigger after which it is allowed to oscillate in a normal condition, but phase coherent to the trigger, and at its normal frequency of 199.2218 MHz, as controlled by the VCO tuning voltage. The VCO output is then passed to the counters on the Count Chain Assembly (A17) through the output gate.

8-119. At the same time, the coincidence flip-flop is held in the set condition for about 35 nanoseconds after the arrival of the input trigger, after which the set enable goes inactive. During this 35 nanoseconds, the Q output of the coincidence flip-flop goes low which disables the gated coincidence output and breaks the feedback loop to the Frequency-Phase detector. Also during the 35 nanoseconds, the Q output of the coincidence flip-flop is high which holds the +256 divider in reset and enables the N1 output gate.

8-120. After the 35 nanosecond delay, the coincidence flip-flop is released from the set condition. With the next low to high output from the Mixer/Synchronizer, which signifies a phase coincidence of the 200 MHz reference and the VCO, a low is clocked to the Q and a high to the Q outputs of the coincidence flip-flop. This sends a phase coincident signal to the DAC/N0 Logic Assembly (A18), enables the divided VCO and the Mixer reference to the Frequency/Phase detector, which then allows the VCO to be frequency corrected if needed, releases the reset on the VCO divider, and disables the gated N1 output.

8-121. The counter now has an N1 count in the Count Chain Assembly (A17), and a START COINCIDENCE signal in the DAC/N0 Logic Assembly (A18). The same operation is performed in the Stop Interpolator (A20) which gives an N2 count in the Count Chain Assembly and a STOP COINCIDENCE signal in the DAC/N0 Logic Assembly.

8-122. A21 200 MHz Multiplier Assembly

8-123. The 200 MHz Multiplier Assembly (A21) multiplies the 10 MHz input to 200 MHz. This is accomplished by two cascaded multipliers (X5 and X4) and filter stages. The 200 MHz is then buffered, sent to the interpolators (A19, A20), and phase adjusted and sent to the DAC Assembly (A18). There is also a separate voltage comparator circuit which compares each VCO tuning voltage from the two interpolators with fixed reference voltages. When either VCO tuning voltage is outside designed limits, a signal is sent to the A17 Count Chain Assembly where it is latched as a status bit.

8-124. A22 Arming Assembly

8-125. The Arming Assembly is responsible for gating the input START and STOP signals to the Start (A19) and Stop (A20) Interpolator Assemblies. This gating can be controlled either internally, externally, or remotely. The Arming Assembly is also responsible for driving the START, STOP, and EXT trigger lights on the front panel, sending a START and a STOP EVENT signal coincident with the START and STOP gate opening to the rear panel jacks J4 and J5, and for partially counting the number of STOP EVENTS ignored in the case of EXT ARM/EXT HOLDOFF or frequency or period gate times.

8-126. In normal operation, the Arming Assembly gates one input signal to each interpolator board. Further input signals are then held off from passing to the interpolators by the processor until the processor is ready for the next sample of input signals.

8-127. The operation is basically the same when using an EXT ARMing input signal. The EXT ARM signal is applied to the machine via J1 on the front panel. Front panel controls allow the operator to select triggering on either the positive or the negative slope. A level control selects the voltage where triggering occurs.

8-128. A23 Display/Control Panel Assembly

8-129. The Display/Control Panel Assembly (A23) contains the seven-segment LED displays, the LED annunciators, and the keyboard.

8-130. A69 10 MHz Oscillator Assembly

8-131. The A69 10 MHz Oscillator Assembly is an oven temperature controlled crystal oscillator with high stability. The 10 MHz output is sent to the A8 Reference Frequency Buffer Assembly. The oven Oscillator Power Supply Assembly (A7) provides unregulated +25 volts to power the oven and regulated +11 volts and +12 volts to power the oven controller and oscillator amplifier, respectively.

8-132. DETAILED THEORY

8-133. The detailed theory of operation is provided in the following paragraphs and listed in numerical order according to assembly number. Each assembly theory refers to its associated schematic diagram located at the end of this section.

8-134. A3 Input Amplifier

8-135. The Input Amplifier consists of two similar input channels, the difference being the input pins 7 and 8 of the Amplifier/Schmitt Trigger ICs. The channels are completely separate. Each channel has ac or dc coupling, START and STOP channels (that can be selected for common or separate operation), selectable 50 Ω or 1 M Ω impedance, an attenuator network, level control, preset control, slope selection, and a high frequency Schmitt Trigger Amplifier.

8-136. START CHANNEL. The circuit theory describes only START channel, since STOP channel is similar. The signal entering jack J3 is sent directly through switch S8 or through coupling capacitor C22, which blocks the signal's dc component. Switch S5 selects SEP or START COM mode of operation. Switch S6 selects resistor R25 for 50 Ω input impedance and resistors R28 and R27 for 1 M Ω input impedance. When S5 is in the START COM position and S6 is set to 50 Ω , the two channels are connected together and resistor R26 maintains the 50 Ω input for each channel. In SEP, the inputs are isolated from each other, R26 is bypassed, and the impedance switches can be set separately. Attenuator Switch S7 passes the signal directly in divide-by-1 or attenuates the signal by 10, in divide-by-10, through divider network R28 and R27.

8-137. The conditioned signal is then routed to the Schmitt Trigger Amplifier U2(8) through one of two paths, depending on the frequency. Frequencies below 10 MHz, including dc, pass through the source follower FET Q3A. Higher frequencies are bypassed around the FET through capacitor C24. Q3A input is protected at low frequencies by resistor R36, and diodes CR5 and CR6. The amplifier U2 has differential inputs and outputs (only one output line is used) and has a gain of about 3. One input accepts the signal and the other accepts the dc level (-2V to +2V) from the front panel LEVEL/PRESET (pot/switch), or remotely via HP-IB. Sensitivity potentiometer R41 enables optimum sensitivity adjustment of Amplifier/Schmitt Trigger U2. Adjusting R41 varies the voltage at the gate of source follower Q3B, thus varying the voltage at pin 7 (TRIG) of U2. Adjusting R41 also varies the voltage at connector J2(2). FETs Q4A/B are current sources for Q3A/B.

8-138. Manual control of trigger level voltage is accomplished by adjusting LEVEL/PRESET control pot/switch (R38). The trigger level can be PRESET to 0 volts, or varied from -2 volts to +2 volts. For remote control via HP-IB, the trigger level must be at PRESET (0V) position.

8-139. The counter may be triggered on either slope of the input signal. The SLOPE switch S9 determines this by controlling the output polarities of U2. If S9 is placed to +, a dc voltage of 3.5 volts is present at U2(6) (SLOPE) which enables U2 to trigger on the positive slope of the input signal at U2(8). If placed to -, 0 volts is present at U2(6); and, U2 will trigger on the negative slope of the input signal.

8-140. A4 Interconnect Board Assembly

8-141. A4 Interconnect Board Assembly directly connects the amplified START and STOP signals from the A3 assembly to the ARMING assembly (A22). The A4 assembly also provides adjustments for the hysteresis and rise time of A3U1 and U2 outputs and controls clamp voltages for the input protection diodes on the A3 assembly.

8-142. START CHANNEL. The circuit theory describes only the START channel, since the STOP channel is identical. The amplified START signal from A3U2(1) on connector J2(6) goes straight through to the A22 ARMING assembly via connector P2(6). Analog Adder A4U1 senses the dc trigger level from A3J2(2) and outputs a corresponding set of dc clamp voltages to the input protection diodes of A3CR9 and CR10. With a nominal trigger level changes, each output is offset by an amount equal to that change. For example, if the trigger level is 1V, the output at U1(1) is -1V (-2V plus +1V) and the output at U1(7) is +3V (+2V plus +1V).

8-143. A6 Power Supply

8-144. The Power Transformer (T1) is connected to the ac supply whenever the 5370B is connected to the line voltage. This provides power from the 16V ac secondary winding to the Oscillator oven Power Supply (A7) to maintain the quartz crystal oven at a constant temperature, even though the 5370B is in the standby mode. The four remaining secondary voltages are rectified, filtered, and applied to the voltage regulation circuitry on A6. The A1 and A6 assemblies provide +5V, +15V, -15V, and -5.2V for distribution throughout the 5370B. These four supplies are derived using linear series-pass regulators.

8-145. All four unregulated voltages are fused at the input of the A6 board. Each of the voltages is routed to the collector of a series-pass transistor (all four series-pass transistors are power Darlington). The +20V unregulated voltage (used for the +15V supply) is sent to a precision regulator (U5) which provides the reference supply (10.0V) for the four controlling operational amplifiers U1, U2, U3, and U4.

8-146. When in the standby mode, the A6U5 precision reference voltage to the operational amplifiers is at 0V, keeping the regulated supplies at 0V. When the instrument is switched on, the precision voltage reference IC provides a reference +10V to the operational amplifiers, which initiates voltage regulation and distribution of the regulated voltages to the rest of the instrument. In both the standby and on modes, power is supplied to the A6 Power Supply Control Assembly; there is no isolation from the transformer. (The remaining circuitry of each voltage regulated power supply is identical, so only the +5V supply will be discussed here.)

8-147. The controller is an operational amplifier connected as a linear voltage comparator. The plus (reference) input is set at +5.05 volts by the resistor voltage divider of R12 and R14. The minus (sense) input is connected to the output of the supply. As the supply varies, the output (U2, pin 6) varies to hold the supply at +5.05V. The supply is slightly higher than 5.00V to compensate for the voltage drop through the 5370B motherboard traces.

8-148. The +5V supply is current limited by A6Q2 and A6R2. In a normal state, A6Q2 is turned off. As the current through A6R2 increases, the voltage drop across this resistor increases. As the voltage drop approaches the bias voltage of A6Q2, it starts to turn on. When A6Q2 turns on, it pulls current away from the base of the power transistor, Q2 on the rear panel, reducing its output. Diode CR2 is a 6V zener used to clamp the +5V supply in case the power transistor shorts. CR2 will withstand enough current to open the fuse, F2. R7 and DS3 work as a monitor to quickly show if the supply is present. R13 is a base current limiter for the power Darlington.

8-149. A7 oven Oscillator Power Supply

8-150. The A7 assembly provides various voltages for operation of the crystal oven. The 16 Vac coming from T1, enters the board on pins P1(3, 4) and is rectified and filtered by bridge rectifier CR1 and capacitor C2. This unregulated +25V first goes through 1.5A F1 to the crystal oven circuit and second through isolation diode CR2 to two regulators. The first regulator is zener diode CR3 with its current limit resistor R2. This produces +11V for the oven control circuits. C3 improves transient response. The second regulator is U1. Its +12V output powers the oscillator circuits. C4 and C5 provide additional filtering. The oven monitor circuit is made of Q1, C1, and R1. The input signal at pin 4 (from A69) has a variable duty cycle with a frequency of about 3 kHz. When the oven is cold, this signal has a long duty cycle. This long duty cycle allows C1 to charge and turn on Q1 which activates the LOVEN line. As the oven warms toward operating temperature, the duty cycle shortens. As the temperature reaches operating level, the duty cycle is such that C1 can no longer bias Q1 on. At this point, Q1 turns off and the LOVEN line is pulled high by the A17 assembly. R1 helps to turn off Q1.

8-151. A8 Reference Frequency Buffer

8-152. The A8 Assembly buffers the reference frequency from either of the two inputs and provides four outputs for instrument operation. The internal input (pin 14) is from the A69 oscillator assembly, the external input is from the rear panel J6. The selection is made by the rear panel FREQ STD switch S3.

8-153. With the FREQ STD switch in INT position, CR2 is forward biased and U2A(5) is at -0.7 volt which is a low. This gives a low at U2A(2) and a high at U2A(3) which connects to U2C(12), U3D(13), and U2B(11), U3C(11), respectively. With this, U2C and U3D are enabled allowing the internal reference frequency to pass, and U3C and U2B are disabled inhibiting the external reference frequency. If the switch S3 were in the EXT position, U2A(5) would be high and the above

state would be reversed allowing the external reference frequency to pass and the internal reference frequency to be inhibited.

8-154. The internal frequency passes through high pass filter R21 and C26 to the input of U6B(9, 10, 11). U6B is a buffer connected as a Schmitt trigger to convert the input 10 MHz sine wave to a 10 MHz square wave. The square wave then passes through two stages (U6C and U6A) of buffering to gate U2C. The resistors R22 (a through f) are tied to -5.2V to improve the rise and fall times of the square wave.

8-155. The external frequency passes through high pass filter R15 and C12 to the base of Q7. Q7 is operated in the non-linear range by bias components R14 and R13 to provide harmonics of the external input. This allows an input of either 10 MHz or 5 MHz. The input signal and harmonics are amplified and applied to tank circuit C15 and L2. This is a 10 MHz tank circuit which shunts all harmonics except 10 MHz. The 10 MHz passes through coupling capacitor C11 to the base of Q9. The circuit of Q9 is the same as the circuit of Q7 with C22 and L4 as the 10 MHz tank. The 10 MHz pass through C20. C21 and L3 form a third 10 MHz tank used to shunt any unwanted harmonic to ground. The 10 MHz is then shaped by U5B and buffered by U5A and U5C and output to gate U2B(9).

8-156. The gated output is sent to four circuits on the board. It enters a one-shot U1A and U1B where it is monitored. LED DS1 remains lit as long as 10 MHz is present. The 10 MHz passes through two buffers U4C and U3B and sent to the time base and auto zero, respectively. The 10 MHz is buffered by U3A and sent to U4B(11) and U4A(5). U4B buffers the 10 MHz and applies it to differential amplifier Q4 and Q5. The output goes to a tapped tank circuit (L1, R5, C7 and C8) and out to the rear panel jack J7. U4A buffers the 10 MHz which is then amplified by differential amplifier Q1 and Q2 and translated to TTL levels by translator Q3.

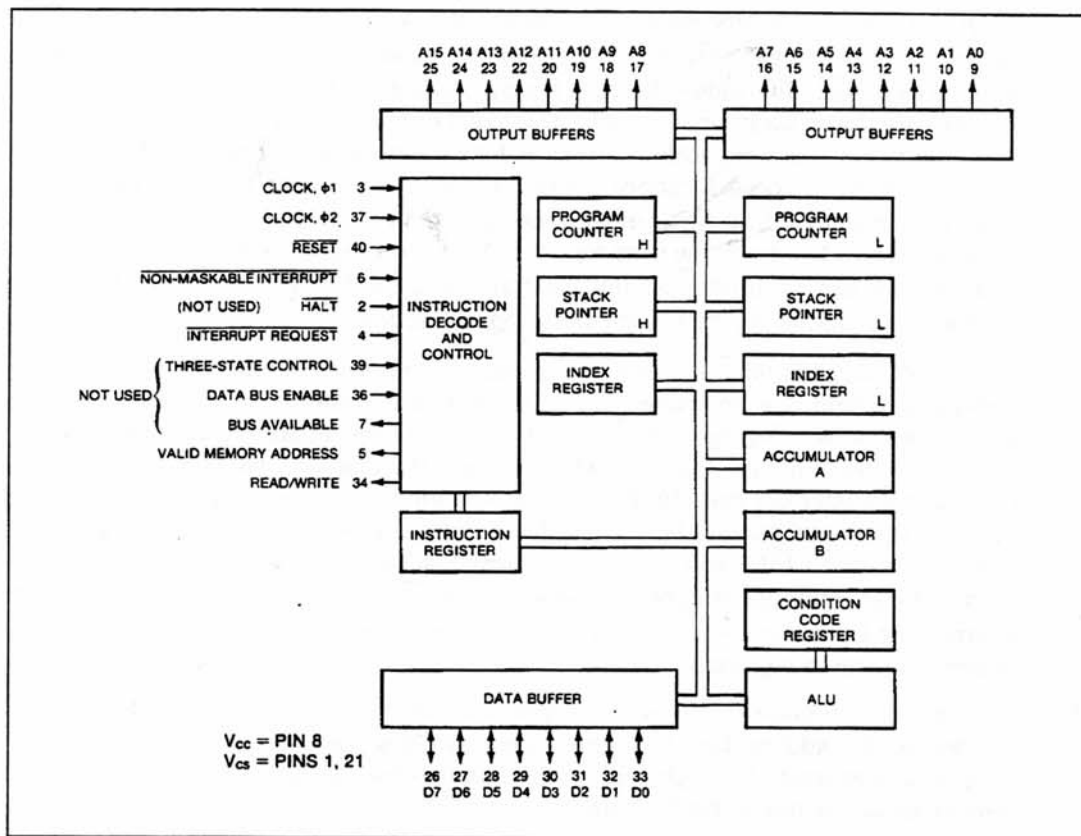

Figure 8-6. U18 Expanded Block Diagram

8-157. A9 Microprocessor

8-158. The A9 Microprocessor (MPU) Assembly contains, in ROM (U3), the operating algorithm of the 5370B. This assembly controls the measurement cycle, performs numerical computations for time interval measurements, and interfaces with many of the other assemblies. The A9 MPU assembly uses the Motorola 6800 MPU (U18). The application in the 5370B is described in the following paragraphs.

8-159. The 5370B uses U18 for control and computation purposes. An expanded block diagram of U18 is shown in *Figure 8-6*. The 16-bit address bus allows the MPU to address up to 65K memory locations. The data bus is 8 bits wide and is bi-directional. Data on the bus is read into the internal MPU registers when the Read/Write control line (pin 34) is high. Data from internal registers drives the data bus when the Read/Write control is low. All operations are synchronized to a two-phase non-overlapping 1.25 MHz clock, $\phi 1$ and $\phi 2$. Each instruction requires at least two clock cycles for execution. The 5370B uses the following additional 6800 control lines:

1. $\overline{\text{RESET}}$ — This input is used to reset and start the MPU from a power-down condition, resulting from a power failure or an initial start-up of the processor. If a positive edge is detected on the input, this will signal the MPU to begin the reset sequence. This will start execution of a routine to initialize the processor from its reset condition. All the higher order address lines will be forced high. For the restart, the last two (FFFE, FFFF) locations in memory will be used to load the program counter. During the restart routine, the interrupt mask bit is set and must be reset before MPU can be interrupted by $\overline{\text{IRQ}}$.
2. $\overline{\text{NONMASKABLE INTERRUPT (NMI)}}$ — A low-going edge on this input requests that a nonmask-interrupt sequence be generated within the processor. As with the $\overline{\text{INTERRUPT REQUEST REQUEST}}$ signal, the processor will complete the current instruction that is being executed before it recognizes the $\overline{\text{NMI}}$ signal. The interrupt mask-bit in the Condition Code Register has no effect on $\overline{\text{NMI}}$. The Index Register, Program Counter, Accumulators, and Condition Code Register are stored away on the stack. At the end of the cycle, a 16-bit address will be loaded that points to a vectoring address which is located in memory locations FFFC and FFFD. An address loaded at these locations causes the MPU to branch to a nonmaskable interrupt routine in memory. $\overline{\text{NMI}}$ has a high impedance pull-up internal resistor, however, a 3 K Ω external resistor should be used for wire-OR and optimum control in interrupts. Inputs $\overline{\text{IRQ}}$ and $\overline{\text{NMI}}$ are hardware interrupt lines that are sampled during $\phi 2$ and will start the interrupt routines on $\phi 1$ following the completion of an instruction.
3. $\overline{\text{INTERRUPT REQUEST (IRQ)}}$ — This level sensitive input requests that an interrupt sequence be generated within the machine. The processor will wait until it completes the current instruction that is being executed before it recognizes the request. At that time, if the interrupt mask bit in the Condition Code Register is not set, the machine will begin an interrupt request by setting the interrupt mask bit high so that no further interrupts may occur. At the end of the cycle, a 16-bit address will be loaded that points to a vectoring address which is located in memory locations FFF8 and FFF9. An address loaded at these locations causes the MPU to branch to an interrupt routine in memory. The $\overline{\text{HALT}}$ line must be in the high state for interrupts to be recognized. The $\overline{\text{IRQ}}$ has a high impedance internal pull-up; however, a 3 K Ω external resistor to V_{CC} should be used for wire-OR and optimum control of interrupts.
4. Valid Memory Address (VMA) - This output indicates to peripheral devices that there is a valid address on the address bus. In normal operation, this signal should be utilized for enabling peripheral interfaces. This signal is not three-state. One standard TTL load and 30 pF may be directly driven by this active high signal.

5. Read/Write (R/\overline{W}) — This TTL compatible output signals the peripherals and memory devices whether the MPU is in a Read (high) or Write (low) state. The normal standby state of this signal is Read (high). Three-State Control going high will turn Read/Write to the off (high impedance) state. Also, when the processor is halted, it will be in the off state. The output is capable of driving one standard TTL load and 130 pF.

8-160. The MPU (U18) is driven by a two-phase clock, $\phi 1$ at U18(3) and $\phi 2$ at U18(37). As shown in *Figure 8-21*, the two-phase clock is derived from the 1.25 MHz output from U13(5). This output is fed through U20, U19, and U17A which is an asynchronous non-overlap clock circuit. This circuit is needed because the 6800 MPU requires non-overlapping clocks. The NPN transistors of U19 are used to pull the clock lines down and the PNP transistors of U19 are used to pull the clock lines up. These transistors are tied together and are driven by the outputs of U20(6,11). Their output, $\phi 1$ and $\phi 2$, is fed back through inverters U20A and U20C to the input of U20D and U20B, respectively. Resistors R25, R27 in the top half of the circuit and R23, R20 in the lower half of the circuit prevent ringing. This allows a guaranteed non-overlapping clock generation without the use of timing elements.

8-161. The address bus is from the MPU and is inverted by U12, U14, and U16. These drive the address bus which goes off the board. They also drive RAMs U10, U8, and U5. The data bus is connected to the RAMs and drivers U1 and U2. These drivers are bi-directional. R1 and R2 are pull-up resistors for the data bus.

8-162. There is a switch pack on the A9 assembly which contains 10 (A through J) individual single-throw, single-pole switches. Switch 1A (S1A) is the receiver enable, S1B is the transmit enable, S1C enables the ROM, S1D is used to disable the RAMs (U5, U8, and U10), S1E is a master disable for the data bus, S1F and S1G are used to put an instruction on the A9 data bus (clear B) which enables the 6800 MPU to free-run for troubleshooting purposes. Switches S1H and S1I are used to enable an 8K byte memory. Switch S1J is not used.

8-163. A11 Display Interface

8-164. The A11 assembly transfers data from the processor to the display, and from the keyboard back to the processor. Both the keyboard and display operate using a timeshare technique.

8-165. Before information can be exchanged, the A11 assembly must be addressed. Address decoding is done by U15, U16, U18A and B, U19, U21B, and U24C. U16(8) decodes the assembly enable address. The four gates U15, U18A and B, and U21B then determine which register or RAM receives the information. U18B(8) address enables registers U9 and U13. When they are enabled, they output their data onto the microprocessor's data bus. U9 contains the scan information for the display and keyboard. U13 contains the code which tells the microprocessor which key has been depressed. U15(8) address enables RAM U7. U7 stores annunciator and keyboard LED information. U10 and U12 are output drivers for the LEDs. U18A(6) address enables RAMs U2 and U4. These RAMs store the segment information for the display readouts. U1, U3, U6, and U8 are output drivers for the display segments. U2, U4, and U7 are location addressed through multiplexer U11 by either counter U17 or by microprocessor address lines A0 through A3. If the RAMs are to read out their data to the display, the location address is from U17. If the RAMs are to write (store new data), the location address is from A0 through A3. U21B(8) enable U11 to select the proper addressing.

8-166. U23 is a dual 4-bit binary counter which divides $\phi 2$ by 256. The output at pin 3 goes through gate U20B and clocks U17(10). U17's binary coded output at pins 4, 5, and 8 drive decade decoders U5 and U14. U5 and U14 decode the binary input and drive transistors Q1 through Q16. Each of the 16 transistors drive a display digit and push-button column on the A23 assembly. The output of U17 also drives RAMs U2, U4, and U7 through multiplexer U11.

8-167. U27A is a monostable flip-flop designed to toggle at 10 MHz. The output is buffered by U25D and sent to the A22 assembly. U27B is a one-shot. When the scan clock is present at U27B(9), the outputs at pins 5 and 12 are high and low, respectively. If the clock should ever stop, the outputs change state. U27B(5) going to the low state, disables U26A and U26B. Their outputs at pins 6 and 8 go high disabling decoders U5 and U14. This blanks the display preventing any digits from being enabled when there is no clock. U27B(12) going high enables U25C. U25C(8) then drives the CLOCK LOSS LED in the front panel display indicating to the user the loss of the microprocessor clock.

8-168. A15 HP-IB Interface

8-169. INTERFACE REGISTERS. There are seven interface registers on A15 which are used by the A9 processor to communicate with the device controlling the HP interface bus. A register is selected by the microprocessor when the microprocessor sends that particular register's address. This address is decoded by one-of-eight decoder U2. Decoder U2 is enabled by the NANDing of address lines LA2 through LA8, LA13, LA14, HEN, and the ϕ_2 clock, all coming from the A9 processor. A particular register is selected by decoding the two least-significant address lines of the microprocessor, LA0 and LA1, in addition to the read/write line, LR/HW also from A9. The following table shows which register is selected for each combination of the three inputs to U2, provided U2 is enabled as previously described.

U2(1)	U2(2)	U2(3)	U2 OUTPUT GOES LOW	ENABLED REGISTER
0	0	0	U2(15)	U13 STATE IN
1	0	0	U2(14)	U8 COMMAND IN
0	1	0	U2(13)	U10 INTERRUPT IN
1	1	0	U2(12)	U28 DATA IN
0	0	1	U2(11)	— — —
1	0	1	U2(10)	U11 CONTROL OUT
0	1	1	U2(9)	U25 STATUS OUT
1	1	1	U2(8)	U22 DATA OUT

8-170. State In buffer U13 is read when the microprocessor wants to determine the state of the interface. Listen flip-flop U19B, Talk flip-flop U16B, Serial Pole flip-flop U19A, Remote flip-flop U16A, and Service Request flip-flop U1B are all buffered by U13. Buffer U13 is enabled by U2(15) going low.

8-171. Command In register U8 is read by the microprocessor whenever an addressed command or universal command is sent by the controller.

8-172. Interrupt In buffer U10 is read by the microprocessor in response to an interrupt. The output of the interrupt buffer indicates why the A15 assembly generated the interrupt (LIRQ low).

8-173. Data In register U28 stores programming codes which have been sent over the HP-IB by the controller. Data In register U28 is clocked by Data flip-flop U6B. After one byte of ASCII program data has been clocked into U28, an interrupt is generated by A15 and the microprocessor reads U10 Interrupt In buffer to find out why the interrupt was generated. Since U10(9) is low, the microprocessor knows that program data is ready to be read from U28. The microprocessor then reads U28. If the byte completes a code (for example, the "5" of the code "SR5"), the microprocessor executes the code and then continues executing the operating program. If the byte does not complete a code, the microprocessor waits until the completed code has been sent.

8-174. Control Out register U11 is used by the microprocessor to control the HP-IB board. For example, in response to a front panel reset, the microprocessor returns the A15 to local control by setting U11(5) low then high, which resets the remote flip-flop U16A. On power-up, U11(15) is set low then high which resets Serial Poll flip-flop U19A, Talk flip-flop U16B, and Listen flip-flop U19B.

When measurement data is sent to the HP-IB, the microprocessor sets U11(2) low which sets the EOI control line of the HP-IB low after the final byte of the data message is sent (i.e., after CR, LF).

8-175. Status Out register U25 is used by the microprocessor to send a status byte to the controller when the serial poll mode is ordered by the controller. The microprocessor sends octal 120 (01010000) to indicate that it has pulled on SRQ (bit 7) and that a measurement has been completed (bit 5).

8-176. Data Out register U22 is used by the microprocessor to output measurement data, one byte at a time, to the HP-IB. U22 is clocked by the Address Decoder U2(7) and is enabled by Serial Poll flip-flop U19A(6) being set low (not serial poll mode).

8-177. COMMAND DECODING ROMs. Decoding ROMs U23 and U26 decode bytes sent over the data lines of the HP-IB. The acceptor handshake operates when LATN (J1 pin 7) is low (address information is being sent) or when the Listen flip-flop U19B(9) has been sent. Decoding ROM U23 is enabled only during the acceptor handshake cycle. The outputs of the ROMs generate interrupts, set or reset various control flags, and are read by the microprocessor via Command In register U8.

8-178. During the acceptor handshake, U7C(12) goes low for one period of the $\phi 2$ clock just prior to the HDAC signal going high, thus enabling U23 (U26 is always enabled). The byte on the data lines of the HP-IB appears at the inputs to U23 and U26. The ROM outputs change accordingly.

8-179. If the Unlisten command is given, U26(1) goes low and U23(2) goes high to clock Listen flip-flop U19B, causing it to be reset. If a talk address other than the 5370Bs talk address is sent, U23(1) goes high to clock into the U16B Talk flip-flop the output of Address Comparator U35. Since the 5370B talk address was not sent, U35(14) is low and the U16B Talk flip-flop is set low. If the 5370B's listen address is sent, U23(2) goes high to clock a high from U35(14) into Listen flip-flop U19B.

8-180. Now that the 5370B is addressed to listen, the following occurs when program data is sent. When program data appears at the inputs to ROMs U23 and U26, U23(5) goes low to set the Data flip-flop U6B. When U23(5) returns high, Data in register U28 is clocked and the data byte is stored in U28. At the same time U23(5) goes low, U23(6) goes low which resets Interrupt flip-flop U9B and causes LIRQ (the output of U12D) to go low and interrupt the microprocessor. The microprocessor reads Interrupt In buffer U10, then determines that program data is in U28, and reads U28. When U28 is read (U28 pin 1 goes low), the Data flip-flop U6B is reset in preparation for the next byte.

8-181. Consider what occurs when an addressed command or universal command is sent by the controller. If a command is sent, U23(4) goes low which set Command flip-flop U6A(4). When U23(4) returns high, it clocks into Command In register U8, the decoded outputs from U28 as follows:

COMMAND	U26(4)	U26(5)	U26(6)	U19(9)	
LLO (Local lockout)	0	0	0	1	} Universal Commands
DCL (device clear)	1	0	0	1	
GTL (go to local)	0	0	1	0	} Addressed Commands
SDC (selected device clear)	1	0	1	0	
GET (group execute trigger)	0	1	1	0	

8-182. At the same time that U23(4) goes low, U23(6) goes low. This sets Interrupt flip-flop U9B and causes LIRQ to go low, which interrupts the microprocessor. The microprocessor reads interrupt In buffer U10, determines that a command code is in U8, and reads U8. The microprocessor determines which command was sent according to the table, and acts accordingly.

8-183. When the serial poll enable is sent, U26(2) goes high and U23(3) goes high to clock Serial Poll flip-flop U19A to the high state. When the serial poll disable signal is sent, U26(3) goes low and U23(3) goes high to clock U19A to the low state.

8-184. ACCEPTOR HANDSHAKE. The acceptor handshake is enabled by U33A(2) low (LATN control line of bus is low, indicating address information is being sent) or U33A(1) low (the 5370B has been addressed to listen). When the talking device puts data on the HP-IB data bus and pulls LDAH low indicating data valid, the acceptor handshake causes HDAC to go high (indicating that the data has been read into U28). After the data in U28 has been read by the microprocessor, the acceptor handshake causes HRFD to go high, indicating that U28 has been read by the microprocessor and that the microprocessor is ready to receive the next data byte.

8-185. A timing diagram of a typical accept or handshake is shown in *Figure 8-7*. The talker places a data byte on the eight data lines, and after allowing for settling, pulls LDAH low to indicate to the listener (5370B in this case) that there is valid data on the data bus. The first positive transition of the $\phi 2$ clock after LDAH goes low, clocks a high into flip-flop U37A(5). This causes the input to U37B(12) to go high. On the next clock U37B(9) goes high and U37B(8) goes low. U37B(9) high and U37A(5) high cause U7C(12) to go low enabling ROM U23. When ROM U23 is enabled, Data flip-flop U6B(9) is set high and U30A(12) goes high (HRFD goes low) which clocks the data into Data In register U28. At the same time, LIRQ goes low to interrupt the microprocessor. The next $\phi 2$ clock causes U37A(5) to return low, thus disabling U23. Since U37A(5) is low and U37B(8) is low, HDAC goes high, indicating to the talking device that the data has been accepted (read into U28) and may be removed from the data lines. The talker then removes the data from the bus and takes LDAH high to indicate that there is not valid data on the bus. U37B(12) goes low when LDAH goes high. On the next positive transition of $\phi 2$, the low at the input to U37B is clocked into the output, causing U37B(9) to go low and U37B(8) to go high. This causes HDAC to return low. After the microprocessor reads the interrupt In register U10 and determines that data is stored in U28, the U28 Data In register is read by the microprocessor. This causes the U6B data flag to be reset and also causes HRFD to go high, indicating that the Data in register has been read and is ready for another data byte. The handshake process than repeats as described.

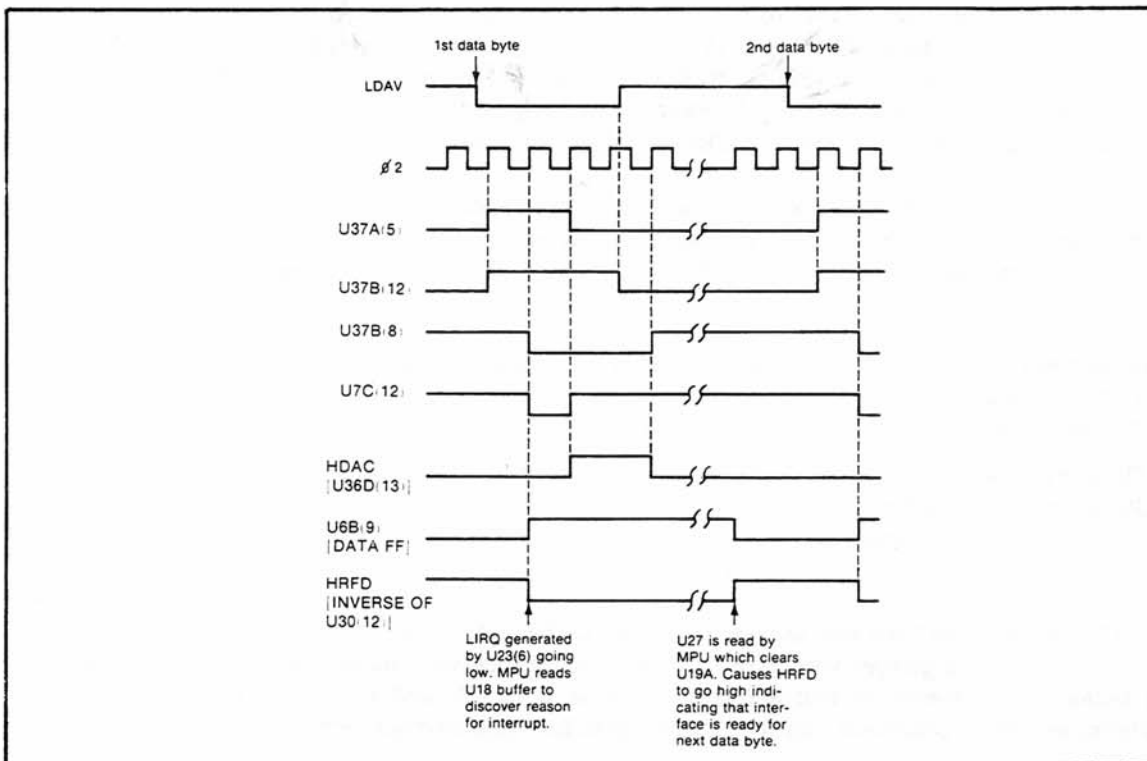

Figure 8-7. Typical Acceptor Handshake Timing Diagram

8-186. SOURCE HANDSHAKE. The source handshake controls the LDAV control line of the HP-IB in response to the state of the HDAC and HRFD control lines which are controlled by the acceptor handshake circuitry in the listening device. When the 5370B operating program finishes a measurement, the microprocessor reads State In buffer U13 to see if the counter has been addressed to talk, the microprocessor reads Interrupt In buffer U10 to determine the state of Data Ready flip-flop U9A. If U9A(5) is high, then the previous data byte has been accepted by the listener and a new data byte may be written into Data Out register U22. When a data byte has been written into U22, U9A(5) is reset low and the source handshake logic sets LDAV low, two ϕ_2 periods later. When the listener sets HDAC high, U9A(5) goes high on the next positive transition of the ϕ_2 clock. Since the listener has accepted the data, a new data byte is written into U22. However, LDAV will not go low again until the listener sets HRFD high to indicate that it is ready for more data. Data Out register U22 is always enabled if the Serial Poll flip-flop U19A is set low. The output data bus drivers U29, 31, 32, and the source handshake circuits however, are only enabled in Talk mode and LATN set high.

8-187. A timing diagram of a typical source handshake is shown in *Figure 8-8*. Since U9A(5) is high, the microprocessor clocks data into U22. This clock also resets U9A(5) low. U9A(5) going low causes the input to flip-flop U27B to go low, and U27B's output goes low on the next ϕ_2 clock positive transition. Since U27B(9) is low and HRFD is high, the input to flip-flop U27A(2) goes high and the U27A(5) output goes high on the next clock. When U27A(5) goes high, LDAV at U33B(6) goes low. Sometime later the listener sets HDAC high to indicate that the data has been accepted. HDAC going high causes the U37B(12) flip-flop input to go high and the U27B(9) output goes high on the next clock positive transition. Since U27B(9) is high and U27A(5) is high, U12(6) goes high and sets the Data Ready flip-flop U9A(5) high. When U9A(5) goes high, U27A(2) input goes low and causes the U27A(5) flip-flop output to go low on the next clock. This causes LDAV to return high. After LDAV goes high, the listener resets HDAC low in preparation for the next handshake cycle. Since U9A(5) is high, the microprocessor writes the second data byte into U22. U22(11) going high resets U9A(5) to a low which sets the U27B(9) flip-flop output low. However, the source handshake logic cannot indicate the presence of the second data byte (by pulling LDAV low) until the listener sets HRFD high. When HRFD finally goes high, the output of U27A(5) goes high on the first clock after HRFD goes high. U27A(5) going high sets LDAV low. When the listener senses LDAV low, it sets HRFD low and the process continues as previously described.

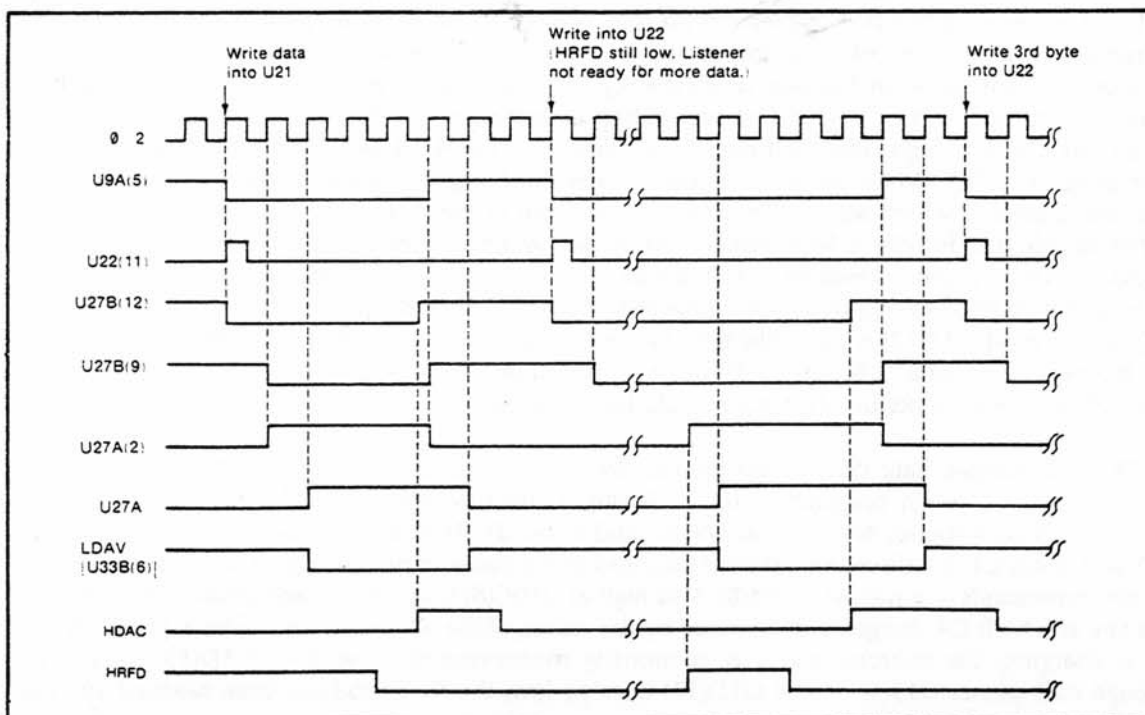

Figure 8-8. Typical Source Handshake Timing Diagram

8-188. A16 Arming Interface

8-189. The A16 assembly contains the address decoder, input/output registers and selector multiplexers needed for control interface between the A22 Arming assembly, A18 DAC/NO assembly, and the A9 Processor assembly.

8-190. The upper 13 (out of 17) bits of the event counter are made of U20, U22, U18, and U13B. The first four are on the A22 assembly. The over-range bit U13B(9) is used by the microprocessor to keep track of the total count. The remaining count data (first 12 bits) goes to multiplexers U19 and U17. This data is then output to the microprocessor data bus as determined by the multiplexer select pins 1 and 15. Program clocking data is sent over the microprocessor data bus and written into storage registers U2, U7, U3, U9, U5, and U11. U6, U4, and U8A and B decode the assembly address and U12 and U14 decode the write and read clocks, respectively.

8-191. U12 generates the write clocks for the six registers U2, U7, U3, U9, U5, and U11. U12 also generates clocks for the DAC on the A18 assembly. When the processor needs to communicate with the A22 Arming assembly, bytes of data are placed on data lines LD0-LD7. Following this, the A16 assembly is addressed, and U12 generates the clocks needed to latch the information into the registers (U2, U7, U3, U9, U5, U11). This information is now latched on the register's outputs and sent to the Arming board.

8-192. Multiplexers U19, U17, U21, and U15 are used to send data from the assembly back to the microprocessor. Data, such as the lower 12 bits of the Event counter and I/O flags, is present on the inputs of these four multiplexers. The read address decoder U14 generates the clocks necessary to enable the four multiplexers which then pass the data onto the microprocessor data bus. The data enabled through is selected by address line LA0. For example, consider what must happen to place the event counter data onto the data bus. First, address line LA0 goes low, selecting the "1" inputs (U19(1), U17(1)). At the same time, U14(13) goes low to enable the outputs of U19 and U17. This places the eight lower order bits (1 byte) of the event counter onto the bus. The microprocessor then latches this byte and addresses the multiplexers for the second byte by placing LA0 high (this selects the data at the multiplexers 0 input) and U14(3) low to enable the data onto the data bus.

8-193. U16A and B and U10B generate an Interrupt Request whenever the Manual Arm or Return-To-Local buttons on the front panel are pressed. When an Interrupt Request is generated in the instrument, the microprocessor addresses each assembly to determine which assembly generated the request. Consider what happens when the A16 assembly generates an Interrupt Request. When either the Manual Arm or Return-To-Local button is depressed, U18C(8) clocks a low to U16A(4) which sets U16A(5) high. This high goes to multiplexer U15(14). It also causes U10B(6) to go low generating an LIRQ. When the microprocessor sees the LIRQ, it addresses the assemblies until it finds the assembly which sent the interrupt. In the case of the A16 assembly, the microprocessor addresses address decoder U14(9) which causes two things to happen. First, it sets U16B(10) and clocks U16A(3) thereby resetting the Interrupt Request, and second, multiplexers U21(15) and U15(15) are enabled to output onto the data bus. When the microprocessor reads the data byte, the IRQ bit (bit 8) at U15(12) is set, indicating to the microprocessor that the A16 assembly generated the interrupt. The data byte also indicates why the interrupt was generated. In this case, bit 2 (Manual Arm) or bit 3 (Return-To-Local) would have been set.

8-194. The Sample Rate (SR), as determined by the front panel SR control, is monitored by the microprocessor through comparator U1D. During a measurement routine, a low is written into U9(12). This corresponds to a high at U9(10) and a low at U10C(8). The low at U10C(8) turns on CR1 and holds C4 at a discharged state. At the end of the measurement, a high is written into U9(10) which corresponds to a high at U10C(8). This high at U10C(8) turn CR1 off and allows C4 to charge. The rate at which C4 charges is determined by the setting of the SR control on the front panel. While C4 is charging, the microprocessor is continually monitoring the output of U1D(13) for a low, through multiplexer U15(4). When U1D(13) does go low, the SR period has been reached and the

microprocessor initiates the next measurement cycle. R7 prevents U1D from oscillating and combination R8 and R15A translate the ECL output to TTL for U15.

8-195. A17 Count Chain

8-196. The A17 assembly contains count chains, adders, and output selector-multiplexers for three 200 MHz signals N0, N1, and N2. The count chains accumulate N0, N1, and N2 counts. The adders subtract the N2 count from the N1 count and multiply this difference by 257. The multiplexers control the transfer of the count data from the assembly to the microprocessor data bus.

8-197. N1 enters the assembly and is buffered by U31B and input to high-speed counters U27 and U24. Their binary output is translated from ECL to TTL by U21A, C, D, and U20A and input to adder U18 and counter U19. U19 and U16B complete the 9-bit N1 count chain. Their outputs are input to adders U13 and U10. N2 enters the assembly and is buffered by U31C and input to ECL counters U28 and U25. Their binary output is inverted and translated to TTL by U21B, U22D, and C, and U20C and input to adder U18 and counter U17. U17 and U16A complete the 9-bit N2 count chain. Their outputs are inverted and input to adders U13 and U10. N1 and $\overline{N2}$ are added together by U18, U13, and U10. However, because N2 is inverted (1's complement), it is effectively subtracted from N1 by the adders. The result (N1-N2) is a 9-bit binary number plus its sign. The lower eight bits (U18 and U13) connect to the A inputs of adders U15 and U7 and to multiplexers U12 and U8. The ninth bit is input to the lowest order B input at U15(6). The remaining seven B inputs are jumpered together and connect to the sign of quantity N1 -N2 coming from U10(1). The sign also connects to multiplexer U9(5). The configuration of adders U15 and U7 effectively multiply the quantity N1-N2 by 257 to yield $257 \bullet (N1-N2)$. This binary number is then output to the microprocessor data bus through multiplexers U12 and U8.

8-198. N0 enters the assembly at P1B(6) and is buffered by U31A and input to high-speed counters U29 and U26. Their binary outputs are translated from ECL to TTL by U22A and B, U23D and U20D and input to multiplexer U6. The fourth bit of N0 is input to U4(10) as the clock for the remaining 13-bit counter U4, U3, U2, and U1B. The binary output is transferred to the microprocessor data bus through multiplexers U6, U5, and U9. U1A is connected as an R-S flip-flop and used to detect an out-of-lock condition of the VCOs on the A19 and A20 Interpolator Assemblies.

8-199. A18 DAC/N0 Logic

8-200. The DAC/N0 Logic Assembly contains two individual circuits. The first is the DAC portion. This is shown on the left side of *Figure 8-33*. The second is N0 Logic portion. This is shown on the right side of *Figure 8-33*. For this reason, the theory is in two parts; the first part discussing the DAC and the second discussing the N0 logic.

8-201. DAC. The DAC contains the circuitry to convert digital information into an analog voltage for remote trigger level programming. Digital information for the DAC comes from two places. The first place is the A9 Processor Assembly. This is the DAC data information from the eight data lines (P1A pins 1 through 8). The second place is the A16 Arming Interface Assembly. This is the DAC control information which controls the DAC operation (P1A pins $\overline{3}$, 4, 5, $\overline{7}$). U2 and U5 are the storage latches for the START DAC. U3 and U6 are the storage latches for the STOP DAC. U4 and U7 are the storage latches for the DAC control data. U1 is the Status Out latch used to store the present status of the DACs for use by the microprocessor. U8 and U9 are 8-bit DACs corresponding to 256 possible output levels. Their output is a current source which is converted by U11 into a voltage. Relay K1 then passes this voltage to the front end.

8-202. The DAC can be used in two modes. Under local control, it is used as an analog-to-digital converter (ADC); under remote control, it is used as a DAC. Therefore, it can be used to read or set the trigger levels of the front end (A3/A4 Input Assembly). When used as a DAC, K1 is closed and

the voltage goes directly to the front end. When used as an ADC, K1 is open and the output of the DAC is compared with the trigger level voltage from the front end by comparators U12C and U12D. The microprocessor ramps the DACs one-bit at a time until the comparator changes state.

At that point, the voltages compare within one-bit (10 mV). The range is +2.55V to -2.56V. The summing of the minus voltage is done by Q1 and Q2. When Q1 is turned on, -2.56V is added to U8(4) output. If U8 input is 0, the result is -2.56V. If U8 gets the largest input of hexadecimal FF (1111 1111), U8(4) output of +2.55V is summed with -2.56V to yield -10 mV. When Q1 is off, and there is a 0 at U8's input, the output is 0V. With hexadecimal FF at the input, the output is +2.55V.

8-203. N0. The purpose of the N0 portion is to determine which coincidence occurs first, generate a 200 MHz burst N0, and inform the processor that the measurement has been completed. U19A tells the processor which coincidence occurs first. If the START coincidence occurs first, U19A(10) is high. When the STOP coincidence occurs at U19A(11), the high at pin 10 is clocked to the output at pin 15 indicating the START coincidence came first. If the STOP coincidence comes first, a low from U19A(10) is clocked to the output U19A(15).

8-204. U15 buffers the 200 MHz time base for use by U17 as a clock, and as the clock for the N0 counting circuits on the A17 assembly. U17, U18, and U16 operate as an exclusive OR. Their function is to allow the 200 MHz (N0) to pass through U16C between START and STOP coincidences regardless of which came first. The following is a description of this exclusive OR function assuming the START coincidence occurs first. In the waiting condition, U17A(7) and U17B(10) are low. Their Q and \bar{Q} outputs are low and high, respectively. Following this to U16B, pin 7 is low, pin 6 is high, and pin 3 is low. U16A pin 4 is high, pin 5 is low, and pin 2 is low. U16D pins 12 and 13 are low, and pin 15 is high preventing the 200 MHz from passing through U16C. At the same time, U18A pins 4 and 5 are low, and pin 2 is high holding U19B in the reset condition with \bar{Q} high and Q low. U18A pins 7 and 6 are high, and pin 3 is low. When the START coincidence arrives, U17A(7) goes high. This high is clocked through, making U17A Q high and \bar{Q} low. This causes U18A(2) to go low, no longer holding U19B in reset. U16B(3) goes low, U16A(2) goes high, and U16C(10) goes low enabling the 200 MHz to pass through.

8-205. When the STOP coincidence arrives, U17B(10) goes high. This high is clocked through making U17B Q high and \bar{Q} low. This causes U16A(2) to go low and U16D(15) to go high, stopping the 200 MHz clock through U16C. It also causes U18B(3) to go high placing U19B in the set condition. In this set condition, U19B goes low signaling the microprocessor that the measurement process has been completed.

8-206. A19/A20 Interpolators

8-207. The purpose of the interpolator boards is to provide the N1 counts for the start channel and the N2 counts for the stop channel. These counts are combined with the N0 counts in a mathematical equation that equals the time interval of the input signal. The N0 counts are gated with the "coincidence" pulses which are also generated on the start and stop interpolator boards when the phase of the startable oscillator equals that of the reference oscillator. The overall block diagram theory describes how these signals combine to form a time interval measurement.

8-208. Since the start and stop interpolators are identical circuits, the text describes the circuit operation in terms of the start interpolator only. The board contains a restartable oscillator that is phase locked to the negative edge of the start pulse. It is this oscillator that produces the N1 counts. The oscillator is stable to the stability specifications of the 10 MHz internal standard. This is done by multiplying the standard up to 200 MHz on the A21 board and then using it as a reference frequency for the phase-lock-loop (PLL) on the A19 board. The PLL controls the stability of the restartable oscillator, which is actually a VCO. The N1 pulses are produced during the time between the negative edge of the start pulse and when phase coincidence occurs between the oscillator and the 200 MHz reference.

8-209. Because of the unusual operation of this circuit, the theory will be presented in a series of building block relating to simplified diagrams of the circuit. The schematic details are described at the end of this presentation.

8-210. THE PHASE-LOCK-LOOP. It is a common technique to control an oscillator's frequency by phase locking it to a standard reference signal. The following diagram (Figure 8-9) shows the simplest example of locking an oscillator to a reference of the same frequency. In this loop, the phase detector monitors the phase difference between the two oscillators and generates a correction signal proportional to the difference. This signal is then filtered and used to change the frequency of the voltage controlled oscillator (VCO). For this type of loop, regardless of the initial phase of the VCO, the ultimate phase of the VCO is totally predictable: it will eventually be in phase with the reference. In other words, the very mechanism which allows the frequency to be controlled destroys the initial phase relationship. The 5370B requires that the VCO be phase related to the start signal.

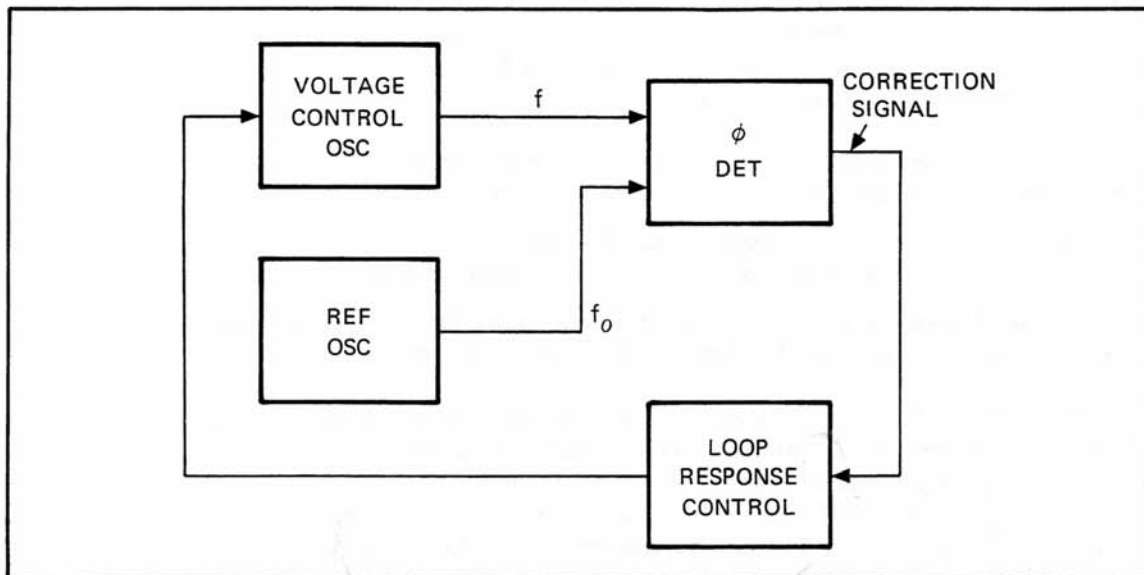

Figure 8-9. A Simple Phase-Lock-Loop

8-211. THE STARTABLE OSCILLATOR. There is a class of oscillators called startable oscillators which, at a given signal, begins to oscillate at a predictable phase and at a preset frequency. A simple startable oscillator is shown in Figure 8-10.

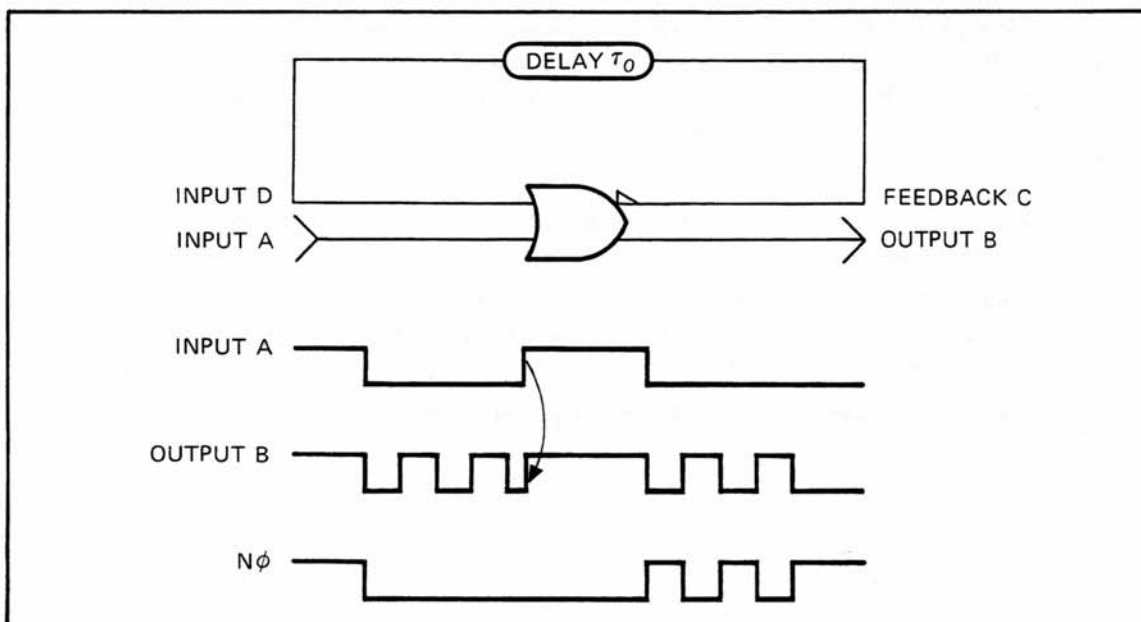

Figure 8-10. A Simple Startable Oscillator With Input and Output Signals

8-212. In the startable oscillator of *Figure 8-10*, input A is initially high, feedback signal C is, therefore, low as is input D. The condition is stable. At a given signal, input A makes a HI-LO transition. This causes C to go high, and later D to go high. This, in turn, causes C to go low, and later D to go low. The condition is never stable and oscillation will continue whose half-period is equal to the external delay plus the gate propagation delay. This oscillation will be in phase with the external signal which makes the HI-LO transition of A. The frequency of oscillation, however, is determined only by circuit parameters which may vary with temperature and other environmental factors.

8-213. Since phase is simply the integration of frequency, it is therefore impossible to maintain the initial phase information indefinitely if the frequency cannot be made precise (relative to a frequency standard for example); because any frequency error, however small, will eventually accumulate through integration to give large phase errors. It is, of course, possible to make such an oscillator into a VCO by inserting a voltage controlled delay (such as a varactor diode) and lock the oscillator to the reference signal by a typical phase-lock-loop. Now the frequency can be made very precise. Unfortunately, this defeats the whole purpose of the startability of the oscillator since the loop will eventually force the oscillator to oscillate at a fixed phase which has no relation to the initial phase generated by the oscillator start signal.

8-214. The 5370B overcomes this dilemma of not being able to obtain simultaneously lockable frequency and indefinite initial phase preservation. The technique uses:

1. A startable oscillator whose frequency can be locked to a given reference frequency standard while maintaining indefinitely its initial phase with predetermined precision.
2. A method of phase-locking which maintains indefinitely the initial phase relationship between the reference oscillator signal and the oscillator being locked.

8-215. IMPLEMENTING THE TECHNIQUE. The A19 Interpolator Assembly uses an oscillator that oscillates with a period of 5.02 ns. This signal is locked to a reference signal of 200 MHz (5 ns period). The two frequencies are therefore locked by the ratio of 100:100.4. Under quiescent conditions, the operation is that of an ordinary synthesizer phase-lock-loop which generates a signal whose period of oscillation is 5.02 ns from a reference oscillator whose period is 5.00 ns. The VCO of this loop, however, is a startable oscillator. More accurately, it is a restartable oscillator in the sense that its oscillation can be momentarily stopped and then resumed at a constant phase with respect to a given "start" signal to the VCO. The phase-lock-loop, meanwhile, undergoes a change so that instead of pulling the VCO back to its original phase, it locks the VCO to the reference at the new phase which is maintained indefinitely to a precision of $\pm 1/256$ of the period.

8-216. PRINCIPLE OF OPERATION. The quiescent condition of the loop can be represented by the following block diagram (*Figure 8-11*). The VCO **1** is a startable oscillator consisting of an inverting gate and external delay. The input A to the gate is low and the oscillator runs at period T which is approximately twice the delay. The oscillation frequency is controlled by the varactor **8** shunting the feedback signal.

8-217. A voltage across the varactor controls the capacitance which in turn controls the frequency of the oscillator. The output of VCO **1** is fed to two channels:

- a. To mixer **2** generating a beat frequency with the reference oscillator. The output of mixer **2** is a signal at the difference frequency $f_0 - f$ where f_0 is 200 MHz and f is the VCO frequency.
- b. To frequency scaler (or divider) **3**. The output of divider **3** is at frequency $f/256$.

8-218. The two signals at frequencies $f_0 - f$ and $f/256$, respectively, are fed through inverting gates 5 and 4 to the input of a phase detector 6. The particular phase detector 6 monitors the LO-HI transitions of the two inputs and produces appropriate pulses at the output which are proportional to the time differences of the LO-HI transitions. The detector output pulses are filtered and integrated, producing a voltage signal to control the VCO frequency via the varactor diode.

8-219. Under locked condition, the two signals DV and MX to the phase detector input are of the same frequency and in phase. Hence, the VCO frequency (f) can be expressed by:

$$f / 256 = f_0 - f$$

$$\text{or } f = \frac{f_0}{1.004}$$

$$\text{where } f_0 = 200 \text{ MHz}$$

$$\text{Proof: } f / 256 = f_0 - f$$

$$f / 256 + f = f_0$$

$$f (1 / 256 + 1) = f_0$$

$$f = \frac{f_0}{1 / 256 + 1}$$

$$f = f_0 / 1.004$$

$$(1.003906249 \approx 1.004)$$

As long as the input A is held low, this locked condition remains. The operation is that of a typical synthesizer loop.

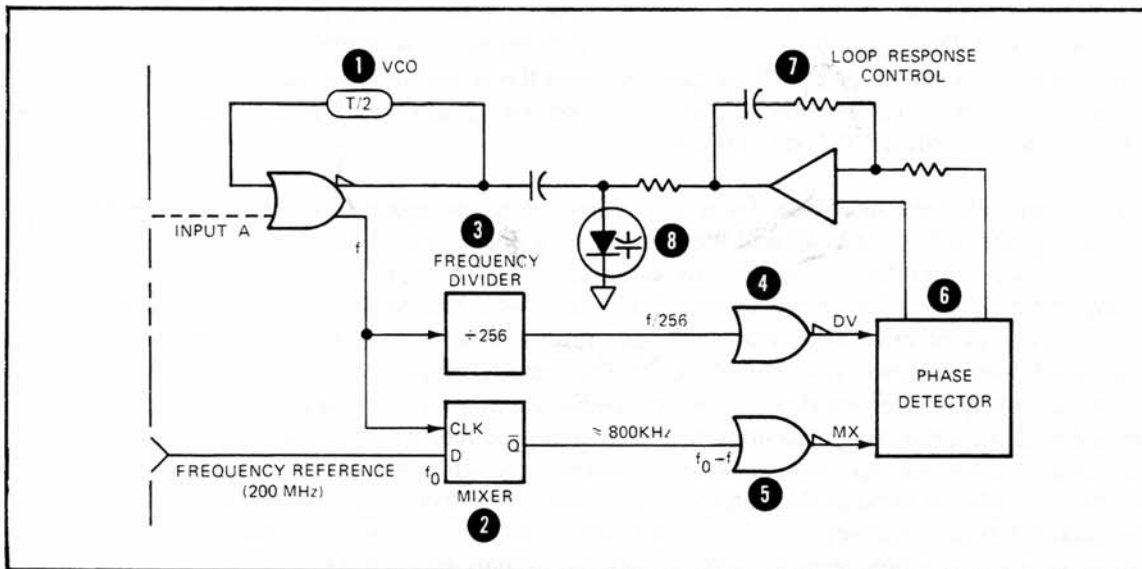

Figure 8-11. Quiescent Condition Block Diagram

8-220. The next diagram (Figure 8-12) shows the block form of the interpolating phase-lock-loop. An input pulse sets lockout flip-flop 9. The time difference τ of the arrival of Q and \bar{Q} to oscillator inhibit gate 11 generates at pulse of duration τ which stops the oscillation of VCO 1 within $T/2(\tau$ is designed to be longer than $T/2$). After τ , the inhibit signal is removed and the oscillation once again commences, but now in phase with the removal of the inhibit, which in turn is precisely τ in time after the input. Therefore, the phase of the new oscillation is directly related to the time of arrival of the input and is independent of the phase of the oscillation prior to the input arrival. The goal is, of course, to maintain this new phase while still frequency locked to the reference.

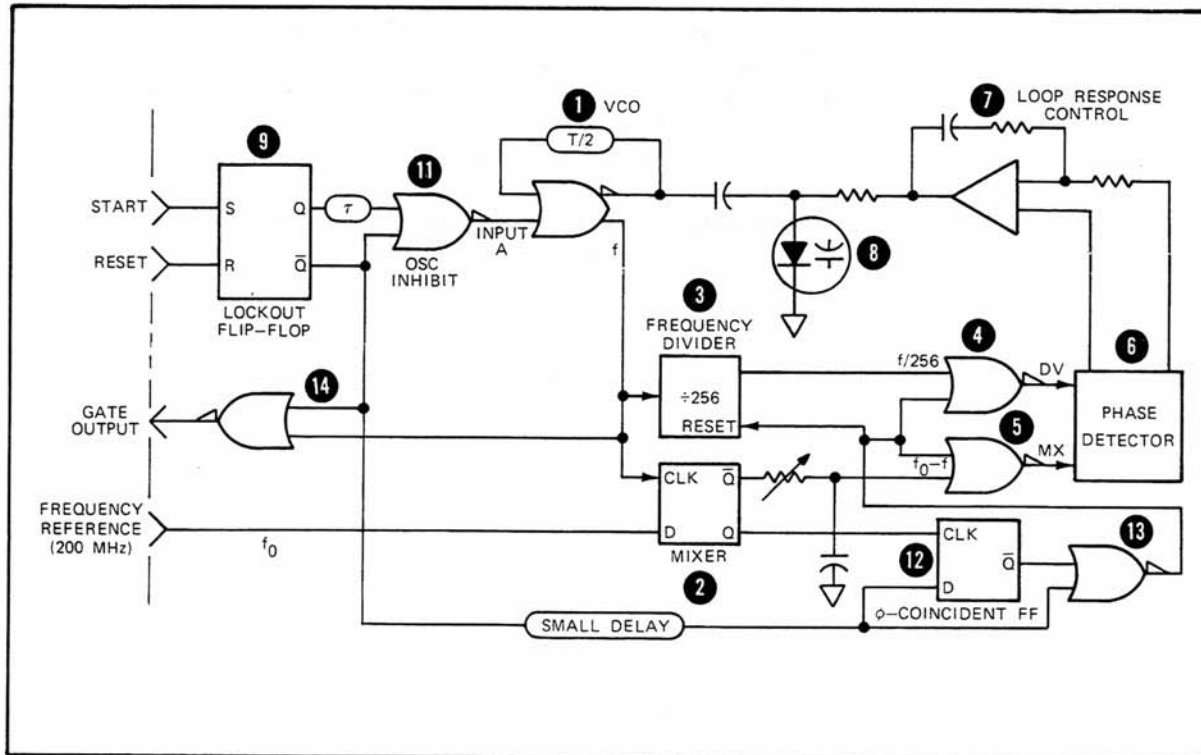

Figure 8-12. Interpolating Phase-Lock-Loop Block Diagram

8-221. The new phase of the oscillator is immediately translated to a new phase of the beat frequency through the mixer. But this new phase is momentarily withheld from the phase detector through the signal S, which goes high as gate 13 senses the arrival of the input through \bar{Q} of lockout flip-flop 9. The signal S causes both DV and MX to go low, disabling the phase detector. The same signal also resets the divider 0 and holds it at 00.

8-222. Meanwhile, the new beat frequency signal from the mixer 2 reaches a natural LO-HI transition, signifying that the VCO and the reference are phase coincident. This transition clocks the phase coincidence flip-flop 12 to the low state (\bar{Q} high). Through gate 13, signal S goes low, allowing the divider to start counting from 6 to 1, 2, ..., etc. The other inputs to gates 4 and 5 are both low at this point since the divider had been reset and held at reset, and also the mixer 2 has just made a LO-HI transition at Q (HI-LO at \bar{Q}). The removal of signal S causes both DV and MX to rise simultaneously. The phase detector, which always monitors LO-HI transitions from both inputs, accepts this as a satisfactory phase-lock condition and produces no significant correction pulses at its output and, therefore, does not cause any frequency change of the VCO. From this point on, the loop acts precisely the same as the quiescent condition before the input arrival. The mixer continues to produce the beat frequency f_0-f , the divider continues to generate the divided frequency $f/256$, and the phase detector continues to monitor these two signals and make small corrections to ensure that they are in phase. Since the divider has been adjusted in phase with the new mixer output phase, phase locking will continue at the new mixer phase. This insures that the VCO will continue to oscillate at its new phase. Should the lock-out flip-flop be reset at this point, the VCO would not shift phase nor would the quiescent lock condition be affected. However, if the lock-out flip-flop is reset, the loop is ready for another input to change the phase of the VCO once again, if desired. The output of the VCO can be obtained at gate 14 which suppresses all oscillations prior to the arrival of the input and after the arrival of an external system reset.

8-223. This following explanation refers to the schematic diagram in Figure 8-34. The A19 and A20 assemblies are the same. For this reason, only the A19 (START) assembly is discussed.

8-224. The input signal from the A22 assembly enters the A19 board at P1A(1) and is input to the first of two gates at U1(16). The inverted output is fed directly to the second gate U1(6). The noninverting output goes through a 10 ns delay, then into the second gate at U1(8). This generates a 10 ns pulse from U1(4), which enters U2(3), gets inverted, and then NORed with the feedback through the delay line by gate B (which is internal to U2). The signal is then buffered and output at U2(11) and U2(13). The signal from U2(13), at a frequency of approximately 199.22 MHz, is divided by 256 by U3, U4, and U5. The output of U5(2) is approximately 780 kHz and is input to the detector inhibit U10(4). The signal from U2(11) goes to mixer U7(13) and is mixed with the 200 MHz reference at U7(3). The output of the mixer U7(6) is the difference, or beat frequency, between the 199.22 MHz and the 200 MHz reference. This difference is approximately 780 kHz.

8-225. The output of mixer U7(6) is used in two places. First, U13A(7, 5) synchronizes the signal with the VCO (U2) output at U13A(6). U13A(3) then goes to detector inhibit U19(7). And second, U8A(7) synchronizes the signal with the VCO output for use as the check for coincidence flip-flop U8B(11). U8B(14) enables U9B(11) to pass N1. U8B(15) resets the frequency divider U3, U4, and U5; generates the coincidence signal through U9A(2, 3, 4); and enables the detector inhibit U10(6, 5). U6 delays the input signal for about 35 ns. After this delay, U8B is ready for the next positive clock transition from the mixer U8A. A transition will come within a 257/200 MHz period. The output at U8B(15) is thereby removed on the first transition, enabling the inputs to the phase detector U2, relocking the loop and allowing the counter to begin counting from zero. U10 employs feedback from U12(12, 3) which generates an extra pulse to guarantee parity of the inputs during disabling. The outputs of U10 are wire ORed and input to the phase detector U12 which develops a phase error signal. The error signal is integrated and filtered and used to tune the VCO.

8-226. There are two outputs on the Interpolator assembly. The coincidence output consists of the NORed outputs of both the anti-coincidence one-shot and the coincidence flip-flop by U9A. The N1 count is the NORed outputs of the VCO and the coincidence flip-flop U8B(14).

8-227. A21 200 MHz Multiplier

8-228. The A21 assembly multiplies the 10 MHz crystal oscillator output to 200 MHz which is used by the Interpolator assemblies and DAC/N0 assembly. There are two multiplier-amplifier filter networks. The first multiplies the 10 MHz by 5 to give 50 MHz. The second multiplies the 50 MHz by 4 to give 200 MHz. The 200 MHz is then buffered and output.

8-229. The 10 MHz enters the assembly on pin P1B $\bar{8}$. C41 and R44 are the termination load. The signal is coupled to 10 MHz amplifier Q6 through C40. R43, R42, and R41 are the bias resistors for Q6. L16 and C56 are tuned to 10 MHz and are the collector load. The amplified 10 MHz is coupled through C50 to X5 multiplier Q8. Q8 generates harmonics of the 10 MHz. L15, C55, and C54 comprise a tank tuned to 50 MHz. C54 is adjusted to peak the tank at 50 MHz. The 50 MHz is coupled to amplifier Q7 through C49. Q7 amplifies the 50 MHz signal which is filtered three times before the next amplifier stage. The first filter network is L14, C53, and C52. The signal is then coupled through C48 to the second filter network; L13, C47, and C51. C42 couples the signal to the third filter network which is L12, C36, and C46. The 50 MHz signal is coupled through C37 and amplifier by Q5. The 50 MHz is filtered two more times before going to the X4 multiplier Q4. The first filter is made of L9, C31, and C33. The second filter is made of L7, C26, and C28.

8-230. The 50 MHz is coupled through C21 to X4 multiplier Q4. Q4 generates harmonics of the 50 MHz and tuned circuit L6 and C20 resonates at the 200 MHz harmonic. The 200 MHz output of Q4 is coupled through C21 to amplifier-filter circuit Q3, L5, and C18. This signal is coupled through C15 to filter circuit L4 and C12. C16 then couples the 200 MHz to amplifier-filter Q2, L3, and C10. The output is coupled through C7 to filter circuit L2 and C6. The 200 MHz signal is coupled through C8 to the final amplifier-filter circuit Q1, L1, and C12.

8-231. The 200 MHz is then coupled through C1 to TP1. The signal at this point is a sinewave. The following circuitry squares, isolates and buffers the 200 MHz signal. The signal passes through R1 which limits the load on amplifier circuit Q1. The signal is limited in both polarities by CR1 and CR2 and applied to the input of Schmitt trigger U1B(9, 10, 11). The squared output at U1B(6, 7) goes to three isolating buffers. U1A buffers the 200 MHz for the A19 assembly. U1C buffers the 200 MHz for the A20 assembly. U2 is a two stage buffer, phase-shifter network. U2B buffers the 200 MHz and outputs the signal (pins 6 and 7) to phase-shifter C22 an R16. This network allows adjustment of the phase of the 200 MHz to compensate for lead-length variations between instruments. The phase-adjusted signal is then buffered by U2A and output to the A18 assembly.

8-232. U3 and its associated circuitry comprise the Lock Status Detector. U3 is a quad comparator. U3D and B are used for the START VCO and U3A and C are used for the STOP VCO. The incoming VCO signal is a dc level and should be between -10V and -3V. Levels outside this range indicate an out-of-lock condition. R22 and R19 set the low limit of -10V at the input of U3D(10) and A(6). R25 and R26 set the high limit of -3V at the input of U3B(5) and C(9). Filters R29-C29 and R30-C30 ensure a pure dc level at the inputs of the comparators, preventing any false triggering. The outputs are tied together and filtered by R23-C23.

8-233. A22 Arming Assembly

8-234. The Arming Assembly is responsible for gating the input START and STOP signals to the Start (A19) and Stop (A20) Interpolator Assemblies. This gating can be controlled either internally, externally, or remotely. The Arming assembly is also responsible for driving the START, STOP, and EXT trigger lights on the front panel, sending a START and a STOP EVENT signal coincident with the START and STOP gate opening to the rear panel jack 14 and J5, and for partially counting the number of STOP EVENTS ignored in the case of EXT ARM/EXT HOLDOFF or frequency or period gate times. The detailed theory is divided into four sections according to their functions. They are: 1) External Arm Input; 2) Trigger Light; 3) Arming Main Signal Path; and 4) Arming Phase Detector.

8-235. EXTERNAL ARM INPUT. The External Arm Input signal comes from the front panel J1 and enters the assembly at J4. The signal is amplified by Q13 and input to comparator U29B(12). U29B(11) is connected to the front panel External input trigger Level which allows the selection of the dc trigger level. When the front panel level control is preset, U29B(11) is grounded. The output of U29B(15) goes into U9B(9) where it is exclusive ORed with the front panel external input slope switch. U9B(11) drives the trigger light circuitry. U9B(10) goes to U1A(4) and generates the arm selection. U1A(5) is the LARMCT2 from A16J1. This signal controls the internal or external arm condition. The external arm comes through U1A and is wire ORed with the manual arm signal which comes from the microprocessor in response to the pushing of the front panel Manual input button. The output of U1A(2) goes to U14B(11) and causes the arm signal which arms the channels.

8-236. TRIGGER LIGHT. The trigger light circuitry is composed of three identical blocks, one for each trigger light. For this reason, only the External Arm trigger light circuitry is discussed. The HEXT signal comes from U9B(11) and enters U18A(4). U18A(5) is biased by the output of flip-flop U22B(3). The output of U18A(2) goes to the D input of U22B(6). With the 10 Hz clock present at U22B(9), the high at U22B(6) is clocked through to U22B(3). This signal is buffered by U30D and sent to the front panel EXT TRIG annunciator. This signal is also fed back to the comparator U18A(5) making the output go low producing a toggle output at U30D(13).

8-237. MAIN SIGNAL PATH. The two input signals come from the A4 assembly. The START signal goes to buffer U20B(16) and the STOP signal goes to buffer U19B(16). The inverted outputs of these buffers go to dual comparator U13(11) and U13(5). The outputs of the comparator drive the auto phase detector and the trigger light drivers. U13(3) provides the STOP EVENTS signal for events counter U3A, U4B, and U2A and B. The noninverted outputs of U20B(11) and U19B(11) are input to signal multiplexers U16(14) and U15(14). The multiplexers select either the internal 10 MHz signal used for calibration or the external START and STOP input signal. The multiplexers also select which

paths the START and STOP input signals will take. For example, if HP TOGL/HCHECK goes high, U6D(13) enables U15B(12) and U16B(12) to pass the internal 10 MHz to the START and STOP arming circuits, respectively. The controlling of the signal paths is dependent on the state of signals HSTASW and HSTOSW. If, for instance, both of these signals are high, the START and STOP input signals pass straight through multiplexers U16 and U15, respectively. And if both HSTASW and HSTOSW are low, the START and STOP signals are routed through U15 and U16, respectively.

8-238. The main measurement signal comes out of U16(3) and U15(3), goes through a delay and into the clock input of U17(13) and U21(13). The inverted outputs (U17 and U21 pin 4) are the trigger signals to the A19 and A20 Interpolator assemblies, respectively. Outputs U16(1) and U15(1) go to inverted inputs U20A(8) and U19A(8). U20A and U19A are inverting buffers. The noninverted signal from U20A(2, 3) and U19A(2, 3) go to U25A(7), and U24B(14), respectively. The arm signal arrives from U14B(14) through an ECL to EECL translator (Q9 and Q10) and is labeled LARM. The LARM signal is wire ORed with the output U28(6) which is the arm signal for \pm T.I. The ORed signal then enters U23A(7) and U25A(8); U23A and U25A are the gates that allow the ARM to go through. The actual ARM pulse comes from U25A(2, 3) and is stored in latch U26A and B. The ARM signal exits the latch at U26A(12, 13) and enters U17(3). The output U17(6) is fed back into U24(16). In \pm T.I., the STOP channel cannot be armed until after the START channel has had an event. The STOP channel works essentially the same as the START channel.

8-239. U24B is functionally similar to U25A. U24B requires that the input from the STOP channel multiplexer be in the low state and not in the external gate mode, or that the external gate be true and an event from the START channel. The STOP channel cannot be armed until after the START channel has had an event. The ARM signal from U24B(12, 13) is latched in U24A and U25B. The output of this flip-flop U25B(12, 13) goes into U21(3). The STOP channel is not fed back into the signal path. The START channel is fed back through a translator Q5 and Q6 into the set input of U28(12) and to the reset inputs of flip-flops U26 and U24A and U25B.

8-240. Up to this point, the \pm T.I. ONLY arm has been discussed. The \pm T.I. arm comes from U28A but it still goes through U25A just like the \pm T.I. arm. In \pm T.I., U23A arms the STOP channel instead of U24B. The three inputs into U23A are: (1) the ARM signal from U28A(6) to U23A(7); (2) the input into U23A(8) from the qualifier that tells whether it is in \pm T.I. ONLY or \pm T.I.; and (3) U23A(6) input from the STOP channel qualifier. The output U23A(2, 3) enters the STOP channel flip-flop U24A and U25B through U24A(8). The ARM flip-flop now is U28A. The D input, U28A(2), comes from translator Q12 and Q11 and is the HARMEN signal from the processor (buffered by U9A). Gates U27A and U27B select the signal. The START channel signal from U20A(4, 5), the \pm T.I. signal U27B(16) and the "select Start Channel as ARM source" signal (U27B(15) is input to START channel gate U27B. The inputs into U27A are the same except for the "select Stop Channel as ARM source" signal. The START and STOP channel selection signals, LSTART and LSTOP, come from translators U7A(7) and U7D(13), respectively. The EXTERNAL GATE signal comes from U14A. The positive-going edge arms the instrument, the negative-going edge arms the gate. The signal out of U14A(2) is translated by Q7 and Q8 and labeled LGATE. LGATE enables the STOP channel to arm after the START channel. In actual operation, the EXTERNAL GATE or EXTERNAL HOLDOFF mode is the leading edge of the EXTERNAL ARM signal. This signal comes in and clocks U14B(11) which generates the arm signal going to U25A. This enables the START channel signal to run through U25A which causes a START channel event. The signal out of the START channel flip-flop U17(6) goes to U24B. The STOP channel signal cannot go through U24B until U14A is clocked (at the trailing-edge of the external arm signal). Its output U14A(2) gets translated by Q7 and Q8 and goes to U24B.

8-241. The noninverted outputs of U17(6) and U21(6) go to ECL comparators U11A(6) and U11A(12), respectively, and are translated to ECL. U11A(1) and U11B(14) go through translators Q2 and Q4 for START and Q1 and Q3 for STOP, and then go to the back panel as START EVT OUT and STOP EVT OUT. U11A(2) and U11B(15) go into inverted inputs U5A(5) and U5A(4), respectively. U5A(2) signal is essentially a START but not STOP signal, i.e., there has been a START channel event but not a STOP channel event. U5A(2) goes to U4A(7). U4A enables the counter and

synchronizes the signal out of U5A(2) with the LSTOPCH signal from U13(3). TP1 is a pulse burst that is made up of the number of events that occurred between the START channel opening and the START or the STOP channel event. U3A, U4B, U2B, and U2A make up the EVENT counter.

8-242. **ARMING PHASE DETECTOR.** The Arming Phase Detector consists of 3 parts: 1) the phase detector itself which is made up of U12A, U12B, and U8A; 2) a flip-flop U8B which determines the initial condition and; 3) U9C, an exclusive OR gate that acts as a selection device. The inputs to the phase detector from U13(14) and U13(2) go to U12B(11) and U12A(6), respectively. The actual detection is done at U12A and U12B. The signal from U12B(14) goes to U8A(7) and the signal from U12A(3) goes to U8(6). If the START signal comes first, the output of U8A goes high when the STOP signal comes. If the STOP signal comes first, the output of U8A is low. The inverter output U8(3) enters U9C(15). U8B disables the Phase Detector when HSTO is sent. If U8B is set, the Phase Detector is enabled, and if U8B is clocked by HTOGGLE, the output U8B(14) toggles. U8B(14) is exclusive ORed with U8A(3) by U9C(13) whose output gets translated by U30B and eventually is sent to the front panel controls.

8-243. A23 Front Panel Display

8-244. The A23 assembly contains the circuits necessary to display the measurement data and to allow the user to program the operation of the instrument. The display is made of 16 digit-LEDs and 30 annunciator-LEDs. The data entry keyboard has 30 keys including LOCAL/REMOTE and RESET.

8-245. **STROBING TECHNIQUE.** A strobing technique is used both to display the measurement data and to monitor the keyboard. Strobing means that only one digit of the displayed number or one column of keys is on at any time. One digit is displayed and then removed; then the next digit is displayed and then removed; then the next digit is displayed and removed. This process continues until all digits have been displayed. The strobing process occurs at a faster rate than the eye can detect, so the display appears continuously lit. The keyboard is monitored the same way; one column at a time.

8-246. Input lines LS0 through LS15 enable the digits (pins 3 and 14), the columns of switch indicator LEDs, and the columns of annunciator LEDs. Input lines DD0 through DD7 enable the digit segments. Input lines LDS0 through LDS7 enable the columns of keyboard switches. Input lines LAN0 through LAN3 enable the rows of switch-indicator LEDs and annunciator LEDs except for annunciators START, STOP, ARM, and EXT. Output lines D0 through D5 monitor the rows of keyboard switches. U1 and U2 drive annunciators START, STOP, ARM, and EXT, and also trigger lights EXT, START, and STOP as determined by their inputs at J4.

8-247. A69 10 MHz Oscillator (Oven)

8-248. This unit is a 10 MHz crystal oscillator whose frequency stability is temperature regulated by an internal oven. The unit incorporates an AGC circuit and is also capable of phase locking to an external standard. Before phase locking can occur, however, the two signals must be within one cycle of each other.

8-249. TROUBLESHOOTING

8-250. Troubleshooting for the 5370B consists of microprocessor address mapping, flowcharts, waveform analysis, and signature analysis. A trouble isolation flowchart is given in *Figure 8-13* and should be used to isolate a problem to the defective assembly. Assembly troubleshooting may then be used to locate the faulty component(s). Assembly troubleshooting is in numerical order and follows the isolation flowchart.

8-251. MICROPROCESSOR ADDRESS MAPPING

8-252. The accessory Service Aid board (A14) contains two DACs that monitor the processor's address lines. The DACs produce an analog voltage that corresponds to the state of these lines. The purpose of mapping is not to make a detailed examination of the processor's algorithm, but instead, to provide a quick and easy check of the processor to determine if it is working properly or if it has stopped in some loop.

8-253. Setup Procedure for Mapping

8-254. The following procedure outlines the proper oscilloscope setup and method for attaining mapping patterns.

1. Set the 1725A Oscilloscope controls as follows:

NOTE

Control settings not referred to are of no significance.

HORIZONTAL DISPLAY.....	X-Y
VERTICAL DISPLAY.....	Y
INT TRIGGER.....	X
BOTH CHANNELS	
VOLTS/DIV.....	5
AC/DC.....	DC

2. Connect a BNC cable from the 5370B 10 MHz FREQ STD OUTPUT (rear panel) to the 5370B START Channel input jack. Set 5370B START COM/SEP switch to START COM ; LEVEL control to PRESET; and DISPLAY RATE pot to fully cw.
3. Set A9 Processor board switches to HHHHLLLHLX* (normal operation condition).
4. Set A16 Arming Interface board switches to HHHHHHHH* (normal operation condition).
5. Connect a BNC cable to the 1725A X input jack and connect a BNC-to-alligator clip leads to the other end of the BNC cable.
6. Connect both black and red clip leads to A14 common (∇) terminal.
7. Use HORIZONTAL POSITION control to place display dot on the leftmost graticule line.

NOTE →
Display dot on left-
most graticule.

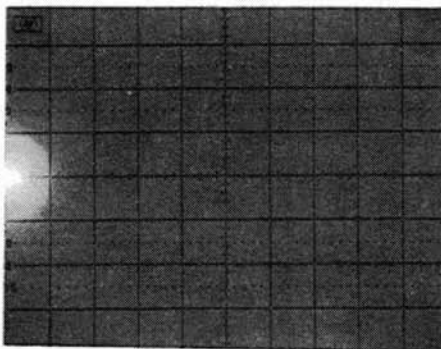

*X = Don't care.

H = Up (towards the top of instrument)

L = Down (towards the bottom of instrument)

Switch settings on A9 and A16 boards are read from left to right.

8. Connect red clip lead to A14 "5.12V" terminal and use HORIZONTAL POSITION control to place display dot to right-side of graticule.

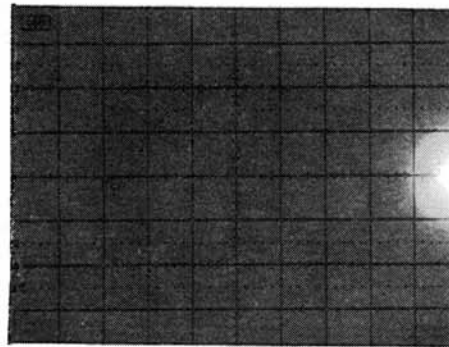

← **NOTE**
Display dot on right-most graticule.

9. Connect red clip lead to A14 "X" terminal and use VERTICAL control to place horizontal line to bottom of display.

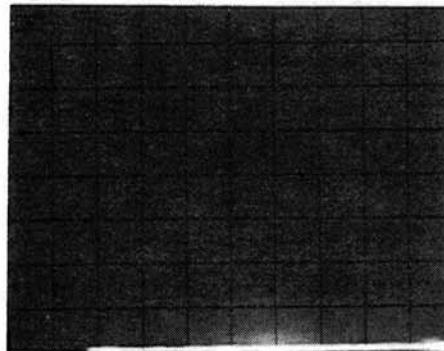

— **NOTE**
Display line on bottom graticule.

10. Connect a BNC cable to the 1725A Y input jack and connect a BNC-to-alligator clip leads to other end of the BNC cable.
11. Connect black clip lead to A14 common (∇) test point and red clip to A14 "5.12V" terminal.
12. Use VOLTS/DIV vernier (not the vertical position control) to bring horizontal line to the second line from the top of graticule.

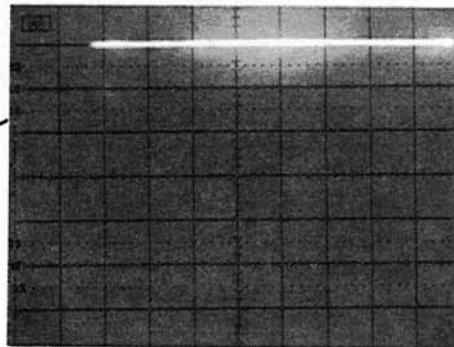

NOTE
Display horizontal line on second line from the top of graticule.

13. Connect the red lead of the Y cable to A14 "Y" terminal. The oscilloscope is now ready to display processor maps.

8-255. Common Map Patterns

8-256. The following figures show most of the counter's "normal" map patterns.

1. This map shows the processor in normal operation with an input it indicates that the processor is working and the front end boards are operational. Although there could be some measurement error in the front end, it is highly unlikely a problem exists in the processor section. If a problem exists and this map is present, a problem could exist in the display boards (A11 and A23), the count chain (A17), N0 part of A18, or, as mentioned, one of the analog boards. If this map should appear with no input signal connected, it indicates the LPROC line is stuck low (A17 or A18). This picture is actually flashing between two program routines: 1) measure computation; and, 2) display rate and interface.

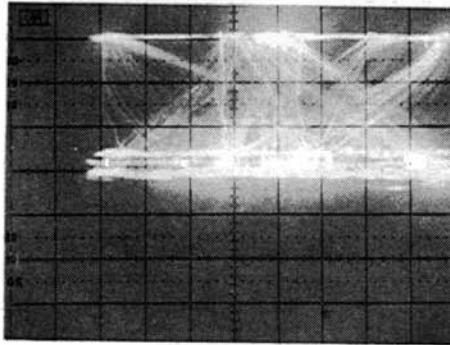

2. This map shows the same measurement as the previous picture but at a SAMPLE SIZE of 100K. Flashing seen in the first picture is slowed as the sample size is increased. As shown below, the processor now stays in the measurement and computation routine longer. There is also a horizontal line (barely visible in the photo) that advances from the bottom of the graticule to top.

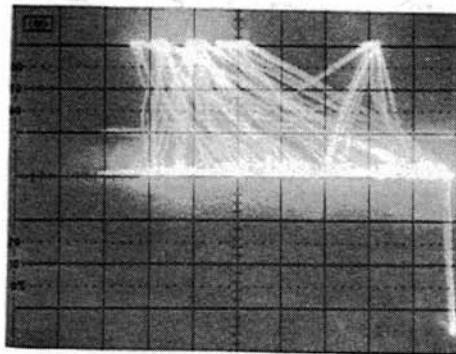

3. This map is an excellent indication of two things: first, that the processor has gone through all of its power-up diagnostics and is working properly; and second, the counter is waiting to be triggered. The problem could be in any one of the front end boards, including the Arming Interface board, A16. The map is also an indication of no input signal.

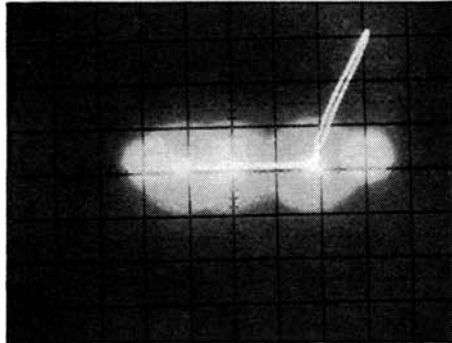

NOTE

Set 5370B START COM/SEP switch to SEP. Be sure that a BNC cable is connected from the 5370B 10 MHz FREQ STD OUTPUT (rear panel) to the 5370B START Channel input jack, in order to attain the map for step 4.

4. This map is similar to the previous one except, in this case, the counter has received a start signal but not a stop. The additional portion in the upper left is the Count Chain board (A17) counting NO pulses. There is also a horizontal line (barely visible in the photo) that advances from the top of the graticule to the bottom. This is the processors index register. Also, note that 10 seconds after reset, Err 02 will appear in the 5370B display.

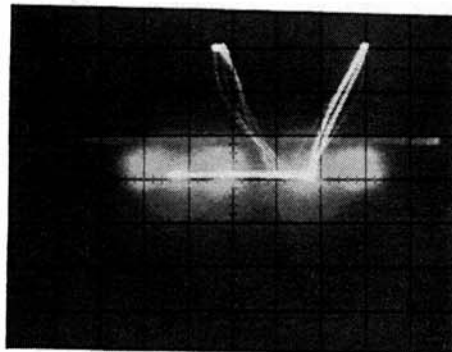

- When the processor is set to the free-run condition for use with signature analysis, it presents a display as seen in the figure below. Free-run is achieved by setting the A9 Processor switches to LLLLLHHHLX. However, it is possible to get the same map under normal setup conditions if the processor "crashes" because of a failure if a test probe slips during troubleshooting.

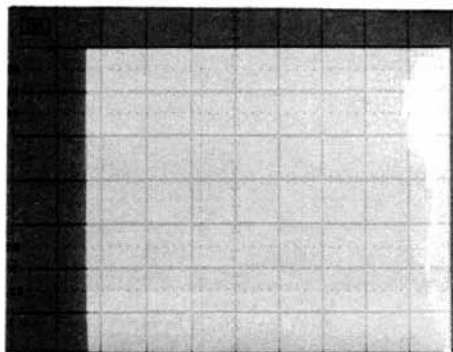

NOTE

Set the A9 Processor switches to HHHHLLLHLX (normal operation condition), before continuing to the next step.

- When the A16 Arming Interface service switches are set to LHHHLLLL and power RES on A14 is pushed, the processor is in a loop always/write mode and provides test patterns for signature analysis. The map of this condition is shown below.

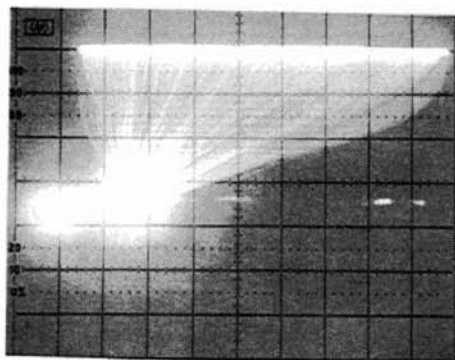

- When the A16 service switches are set to LHHLHHLL and A14 power up RES is pushed, the processor performs a loop always/read function, again for signature analysis. The "read" map is shown below.

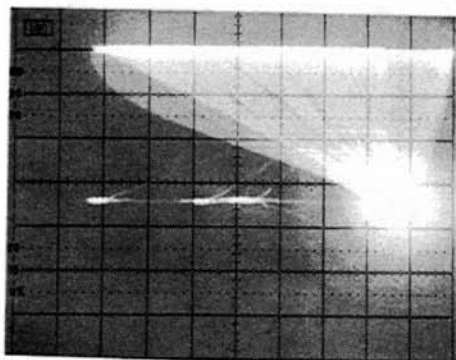

8. This map is simply a combination of the previous two. It is generated by setting the A16 service switches to LHHHLHLL and pushing A14 power up RES switch.

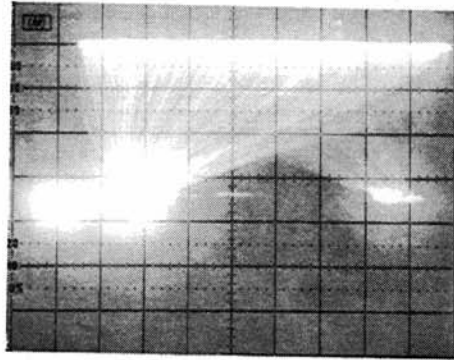

9. The map shows the processor performing the loop-always/display-test loop. This routine is initiated by setting the A16 service switches to LHHHLHLL and pushing A14 power up RES switch. The map shows the 2- to 3-second wait loop that exists between display updates. Under normal power up conditions, the wait loop is also entered to provide time for lamp-test display.

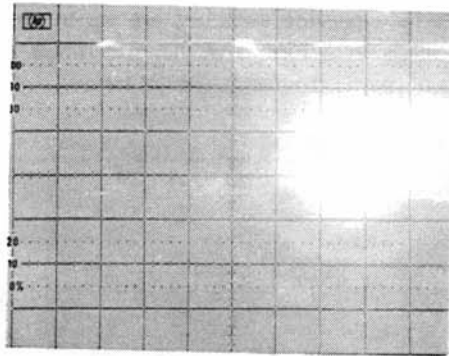

NOTE

Set A16 Arming Interface board switches to HHHHHHHH, before continuing to the next step.

10. Pressing and holding the front panel RES button places the processor in a loop that produces the characteristic map shown below.

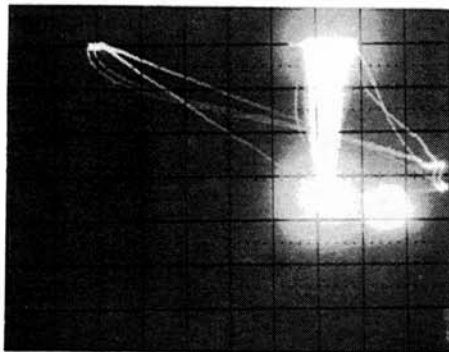

11. This is a map of the "Display Rate Hold" routine. If this map is displayed at an inappropriate time, it could indicate a processor problem or a problem on the Arming interface board (A16), the Arming board (A22), or Display/Push-button board (A23). This would include the interconnecting cable. To obtain the following map, turn DISPLAY RATE knob to "hold" position, then press the counter RESET button.

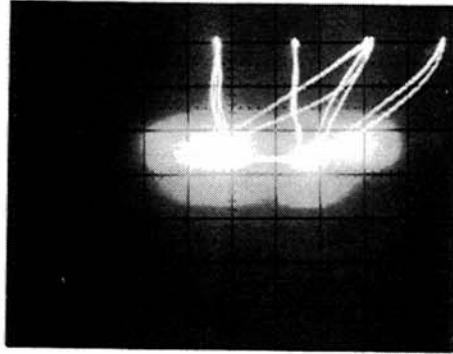

12. These following three maps show the trigger level routine, which is entered when the TRIG LVL button is pushed. The first map was taken with both LEVEL controls in the PRESET position (0V). The second map shows the LEVEL controls set to -2V and the third map shows both controls set to +2V. All three maps are essentially the same. Some areas are more intense than others, indicating that the processor is completing its routine faster and therefore entering the program locations more often.

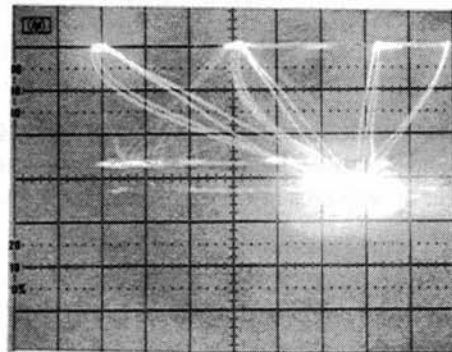

0 Volts

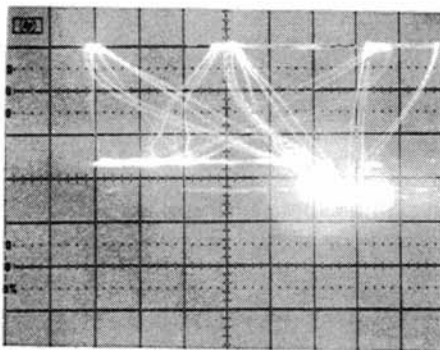

-2 Volts

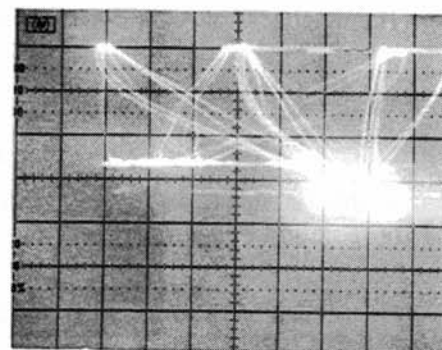

+2 Volts

8-257. A3/A4 INPUT AMPLIFIER/INTERCONNECT BOARD TROUBLESHOOTING

8-258. To troubleshoot the combination A3/A4 assembly, set the 5370B front panel controls as follows:

BOTH LEVELS
LEVEL PRESET
IMPEDANCE..... 50Ω
SLOPE \mathcal{F}
ATTENUATION 1
START COM/SEP SEP
AC/DC..... DC
Front panel controls not referred to re of no significance.

NOTE

The following measurements are taken with no input signal to either channel.

DC Voltage Checks:

1. Connect 3435 DMM positive lead to pin 8 of A3U2 (START Channel Hybrid) and connect negative lead to pin 11 (∇) of A3U2. The dc voltage reading should be **<100 mV**. Next, connect the DMM positive lead to pin 7 of A3U2. The dc voltage reading should be **<100 mV**. If these voltages are **<100 mV**, skip to step 3.
2. Using the 3435 DMM, check the voltages at TP2 and TP1 of A3 assembly. The dc voltage at TP 2 should be **0V** and the dc voltage at TP1 should be **0 to 20 mV**. If these voltages at TP2 and TP1 are not present, troubleshoot to find the faulty component(s).
3. Repeat steps 1 and 2 for dc voltage checks at pins 7 and 8 of A3U1 (STOP Channel Hybrid), TP4, and TP3.
4. Using the 3435 DMM, check dc voltages at pins 1 and 7 of A4U1 (START Channel BI FET). The voltage at pin 1 should be **-2V ±200 mV** and the voltage at pin 7 should be **+2V ±200 mV**. If these dc voltages are within specifications, skip to step 6.
5. Check CR9 and CR10 on A3 assembly; then, check CR1 and CR2 of A4 assembly. If these diodes on A3 and A4 assemblies check good, replace U1.
6. Using the 3435 DMM, check dc voltages at pins 1 and 7 of A4U2 (STOP Channel BI FET). The voltage at pin 1 should be **-2V ±200 mV** and the voltage at pin 7 should be **+2V ±200 mV**. If these dc voltages are within specifications, skip to step 8.
7. Check CR11 and CR12 on A3 assembly; then, check CR3 and CR4 of A4 assembly. If these diodes on A3 and A4 assemblies check good, replace U2.
8. The dc checks of A3 and A4 assemblies are now completed.

Signal Checks:

NOTE

At this point, we are interested in the waveform amplitude ONLY. If you observe some ringing, try using a shorter ground lead on your scope probe.

1. Connect a BNC cable from the 5370B 10 MHz FREQ STD OUTPUT to the 5370B START Channel input.

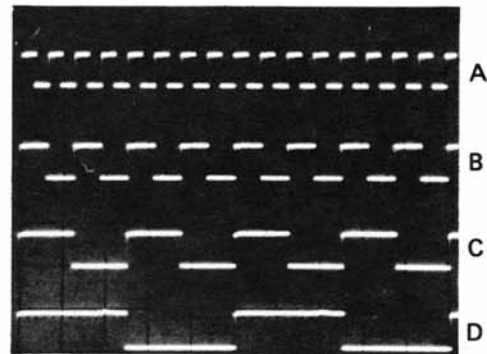
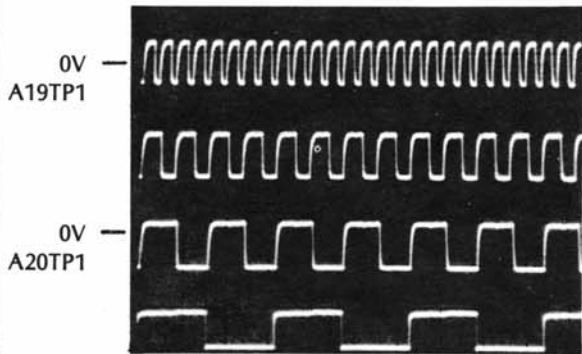
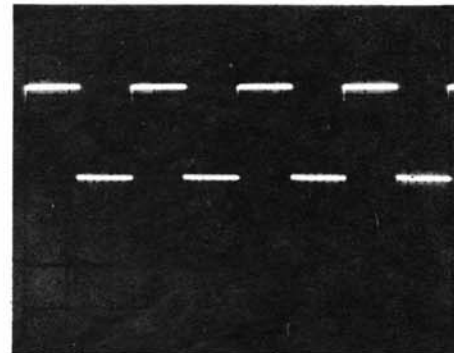
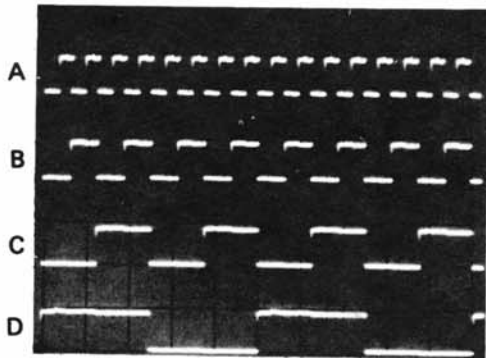
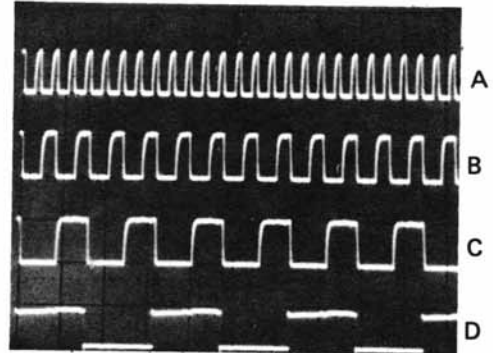
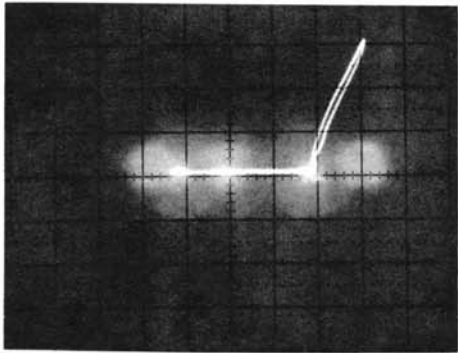

First part of page 8-53, which folds out.

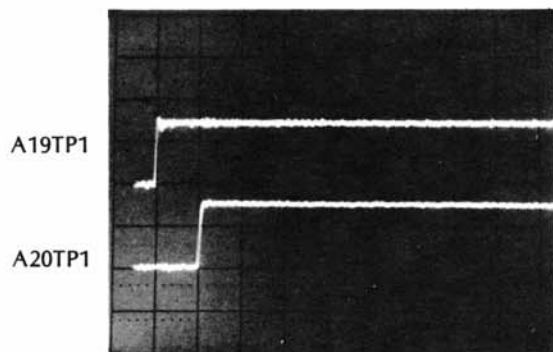

7

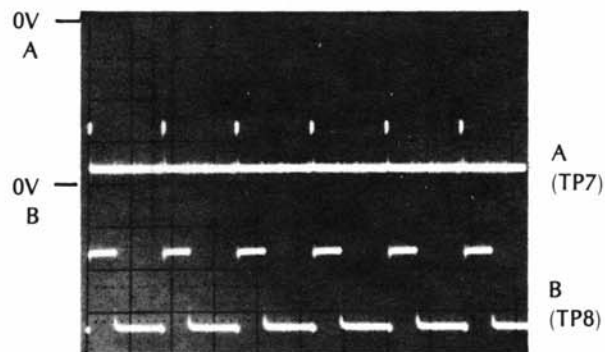

8

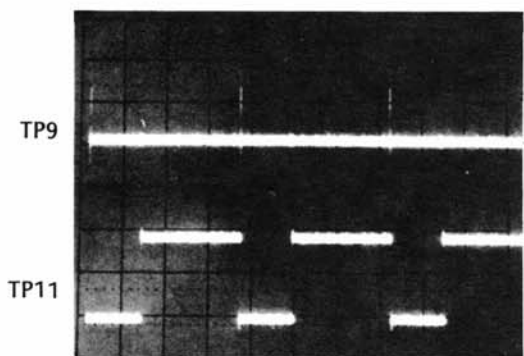

9

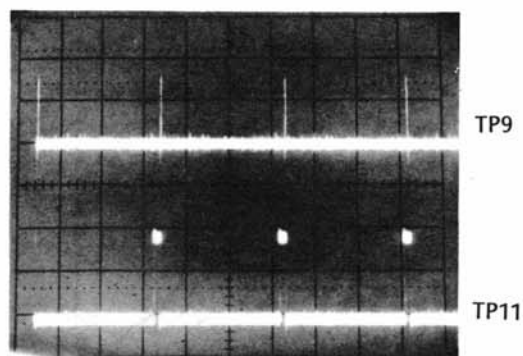

10

Second part of page 8-53, which folds out.

Sig Set
 ①
 A16J1(1) 838A
 A16J1(2) 6P57
 A16J1(3) 294A
 A16J1(4) 8PHF
 A16J1(5) 87F3
 A16J1(9) OF66
 A16J1(10) A677
 A16J1(11) 711U
 A16J1(12) UJUF
 A16J1(13) 7242
 A16J1(14) 1COH
 A16J1(15) A137
 A16J1(16) 1UBF
 A16J1(17) 87F3

Preliminary checks: With that the four LED's on the Ensure that the rear panel "Clock Loss" LED is off. Check that the service switches are set to normal supplement that may be c

If an error message app portion of the instrumen

Always turn c installing any

Connect an XY oscillosc under Microprocessor A shown in Figure 1? (The processor section i followed by "0.00" with 1 and ARM lights on. If nc if the problem is in the p

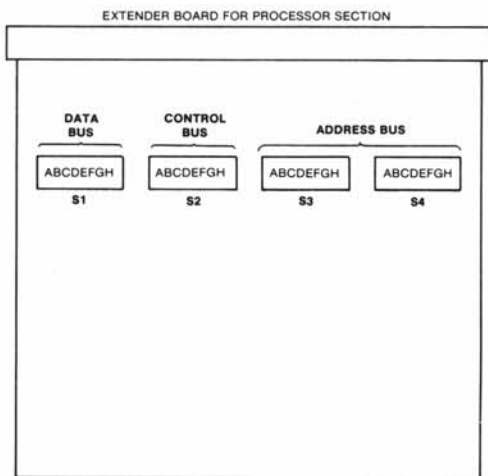
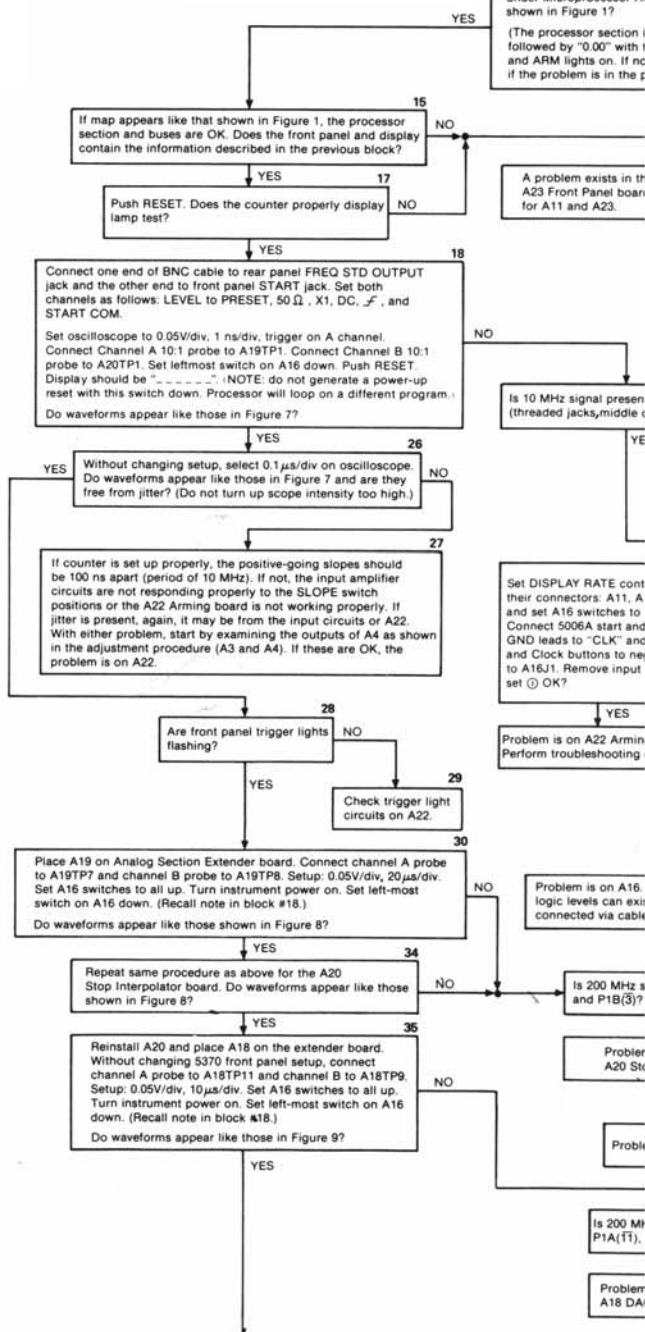

Table 1. Troubleshooting Hints

1. If pushing one of the front panel pushbuttons does not activate the selected function, as indicated by the light staying on, the problem is either a bad switch or a problem on the A11 Display Interface board. This is assuming the processor is working properly, that the selected key function is legal, and that the pushbutton LED is good, which can be checked with lamp test.
2. If the counter works in the \pm TI Arming mode but not in one of the other arming modes, including external arming, the problem is on A16, A22, or possibly on A18. Perform the A16 Arming Interface troubleshooting first and then the A22 Arming board troubleshooting.
3. If the counter is working but gives erratic displays, the Overall Troubleshooting Flowchart should be able to isolate the problem to the board level. Also, see hint #4 below.
4. If the counter works correctly in the TI mode but not in FREQ or PERIOD mode, the problem may be caused by the automatic calibrate routine (see A22 Arming board troubleshooting) or a problem exists in the Event Counter circuits, which are located on A22 and A16.
5. If the counter powers up correctly with no input signal applied but the ARM light is not lit, check the A16 Arming Interface board and A22 Arming board. This is especially true if the counter will not make a measurement.

Table 2. Error Messages

- Err 1: Illegal Remote Command. Programmer has entered a nonvalid program code.
- Err 2: Time Interval Overrange. Typically, measurement has accumulated more counts than the software can handle in its arithmetic computations, because of operating conditions. If an actual problem exists, it may be because the internal circuits are receiving a start signal but not a stop signal (see Figure 11), or a problem may exist in the A17 Count Chain board (probably in the N0 count circuit).
- Err 3: Undefined Routine. For possible future use.
- Err 4: PLL Out of Lock. 1) One of the oscillator circuits on A19 or A20 is not phase locked. Interpolator "VCO" test point should be between -3V and -6V. (A21 board may be bad or no 10 MHz signal to it.) 2) The out-of-lock detector on A21 Multiplier board is bad. 3) The out-of-lock flip-flop on A17 Count Chain board is bad. 4) The multiplier that passes the lock information on A17 is bad.
- Err 5: Undefined Key. A hardware problem, probably on the A11 Display Interface board.
- Err 6.N: RAM Error. When the instrument is turned on, a diagnostic routine checks the RAMs. If a RAM is bad, Err 6.N is displayed. The "N" is a number that refers to the specific RAM at fault. For example, if Err 6.3 is displayed, replace the third RAM from the left.
- Err 7.N: ROM Error. When the instrument is turned on, a diagnostic routine checks the ROMs. If a ROM is bad, Err 7.N is displayed. The "N" is a number that refers to the specific ROM at fault. For example, if Err 7.4 is displayed, replace the fourth ROM from the left. Err 7.9 indicates one of the ROMs is missing or not being enabled.



Third part of page 8-53, which folds out.

Sig Set

1	A16J1(1)	838A
	A16J1(2)	6P57
	A16J1(3)	294A
	A16J1(4)	8PHF
	A16J1(5)	87F3
	A16J1(9)	CF66
	A16J1(10)	A677
	A16J1(11)	711U
	A16J1(12)	UUUF
	A16J1(13)	7242
	A16J1(14)	1COH
	A16J1(15)	A137
	A16J1(16)	1U8F
	A16J1(17)	87F3

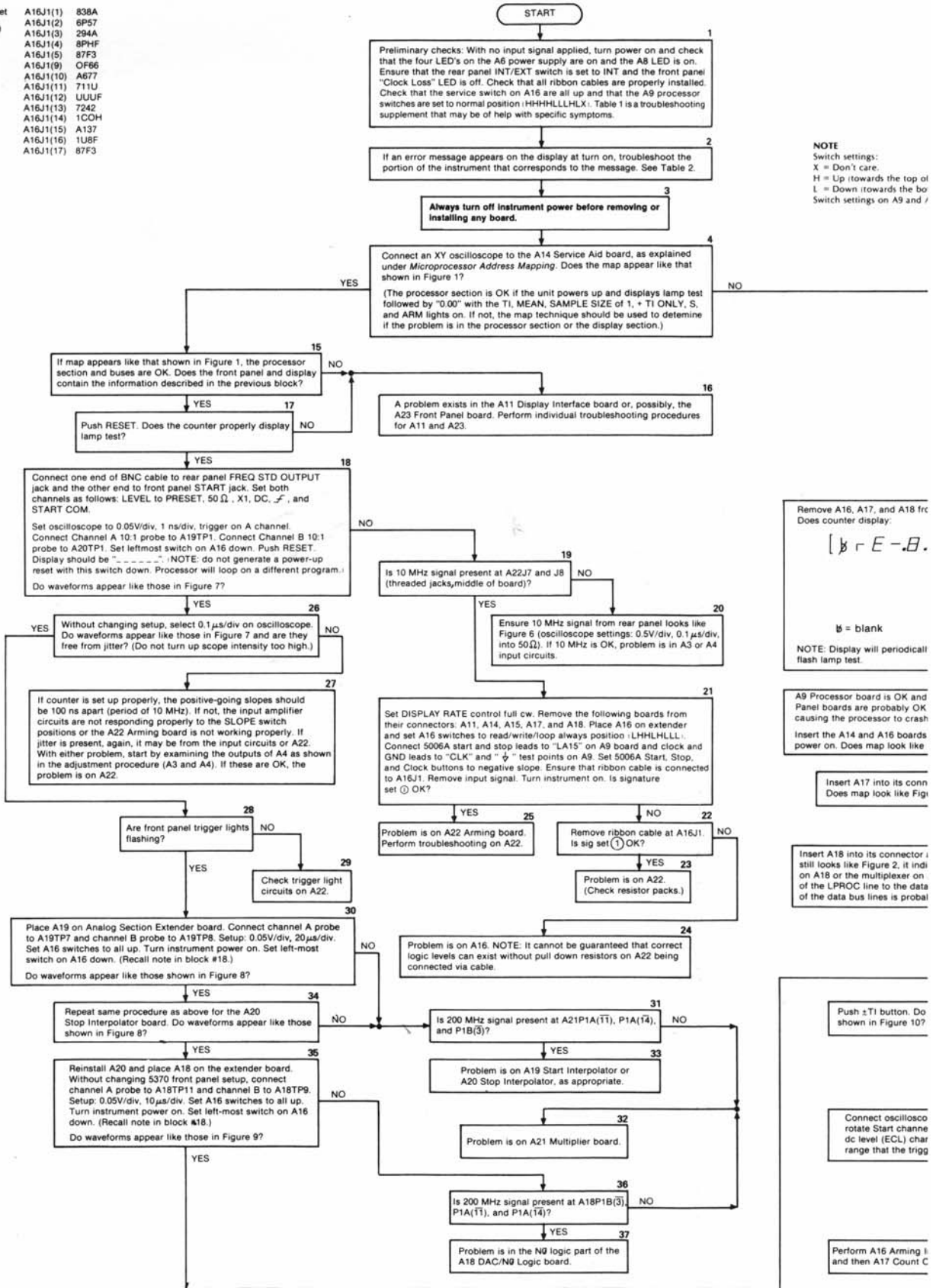

NOTE
Switch settings:
X = Don't care.
H = Up (towards the top of
L = Down (towards the bottom)
Switch settings on A9 and 7

Remove A16, A17, and A18 from
Does counter display:

$\text{b} - E - B.$

b = blank
NOTE: Display will periodically
flash lamp test.

A9 Processor board is OK and
Panel boards are probably OK
causing the processor to crash
Insert the A14 and A16 boards
power on. Does map look like

Insert A17 into its connector
Does map look like Figure

Insert A18 into its connector,
still looks like Figure 2, it indi
on A18 or the multiplexer on
of the LPROC line to the data
of the data bus lines is probal

Push $\pm T1$ button. Do
shown in Figure 107

Connect oscilloscope
rotate Start channel
dc level (ECL) char
range that the trigger

Perform A16 Arming
and then A17 Count C

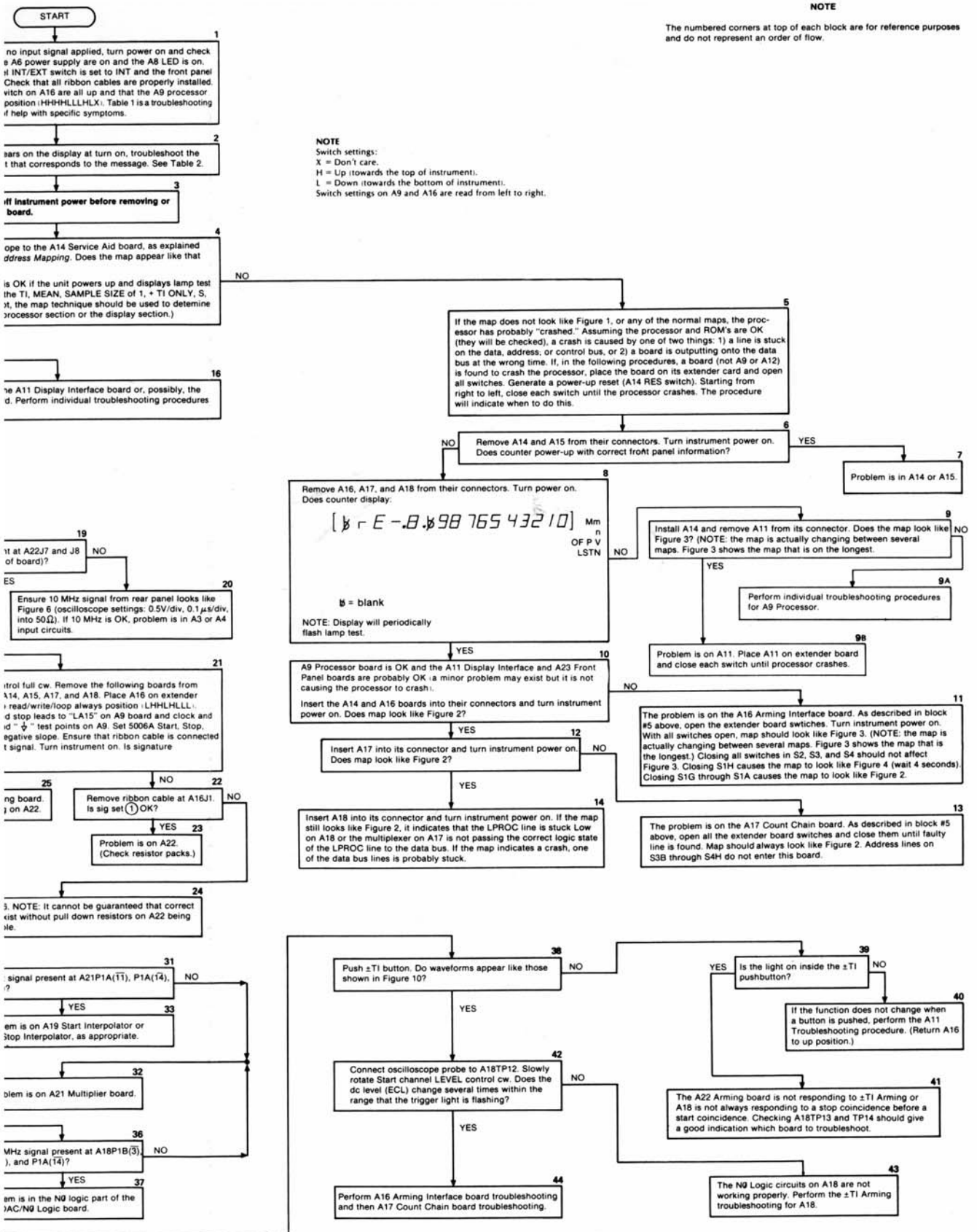

Figure 8-13. Troubleshooting Assembly Isolation Flowchart
Fifth (and final) part of page 8-53, which folds out.

2. Using the 1725A Oscilloscope, connect a probe to pin 1 of A3U2. Observe a negative square wave with an amplitude of at least -600 mV. If waveform is within specifications, skip to step 4.
3. Connect the scope probe to pin 8 of A3U2 and observe a 10 MHz 1V p-p sine wave. If a 1V p-p sine wave is present, replace U2. If a 1V p-p sine wave is not present, troubleshoot back for the faulty component.
4. Connect a BNC cable from the 5370B 10 MHz FREQ STD OUTPUT to the 5370B STOP Channel input.
5. Repeat steps 1 through 3 for 5370B STOP Channel. But, observe the -600 mV waveform at pin 1 of A3U1 and the 1V p-p sine wave at pin 7 of A3U1.
6. After checking and correcting both channels, perform the A3/A4 adjustments given in Section V.

8-259. A8 REFERENCE FREQUENCY BUFFER TROUBLESHOOTING

8-260. Begin troubleshooting the A8 assembly by first placing the assembly on an extender board (i.e., 5060-0049 extender board found in the 10870A service accessory kit). The following seven photos show wave shapes which appear at the designated points throughout the circuit. The first five are those wave shapes of the internal 10 MHz clock with the rear panel FREQ STD switch in INT. The last two show wave shapes found in the circuitry used to shape and develop the external time base input. For the last two photos, an external 10 MHz is applied to the rear panel jack J6 with the FREQ STD switch in EXT position. All wave shapes were taken using an HP 1725A oscilloscope with an HP 10017A probe. No special front panel setup is necessary.

REAR PANEL FREQ STD SWITCH INT
USE 10 DIVIDER PROBE HP 10017A

0.1V/div., 50 ns/div.

TP INT
U2C(13)

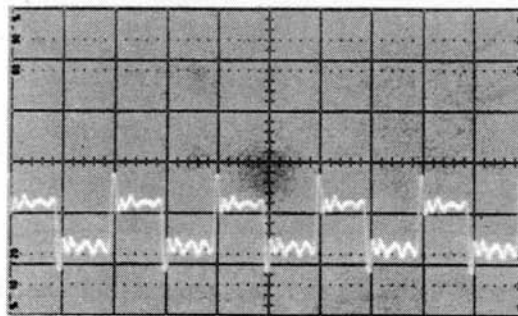

0.1V/div., 50 ns/div.

U1(6)

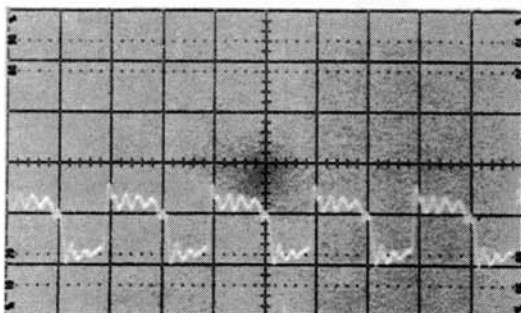

0.1V/div., 50 ns/div.

U4(14)
U3(2, 3)

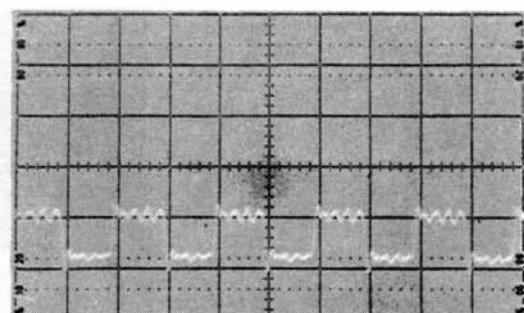

0.1V/div., 20 ns/div.

10 MHz EXT
OUTPUT (Junction
of C7 and C8)

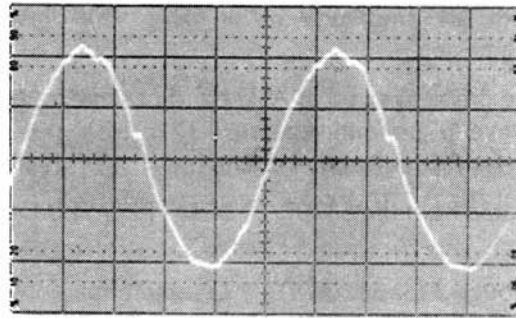

0V

0.1V/div., 20 ns/div.

10 MHz CLK
(Collector of Q3)

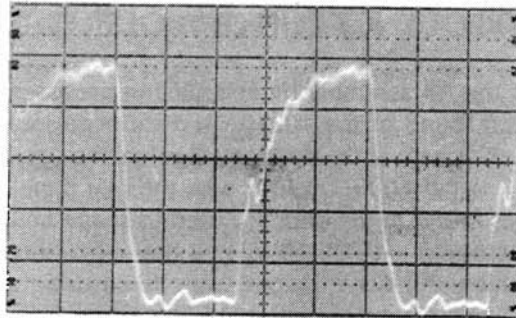

0V

REAR PANEL FREQ STD SWITCH EXT WITH 10 MHz INPUT AT REAR PANEL J6

0.2V/div., 20 ns/div.

A8P1A(8)

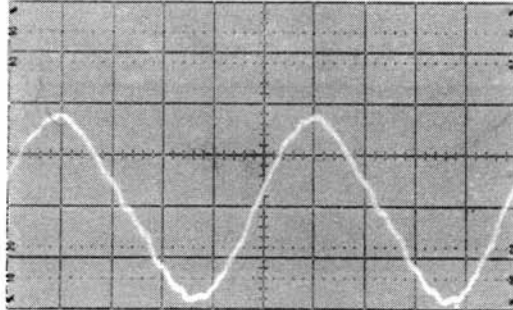

0V

The last signal has a dc offset such that it can only be seen if it is inverted by the oscilloscope. To do this, move the probe to Channel B and press B Invert.

.05V/div., 20 ns/div.

TP EXT
U2B(9)

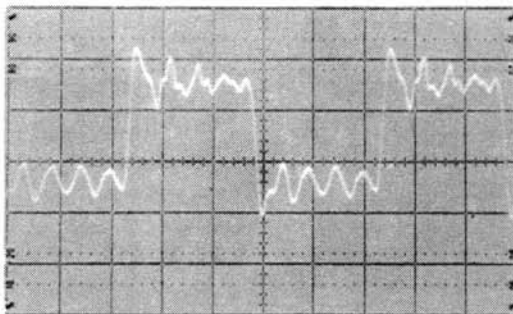

0V

① CLOCK/ROM Signatures

U11:2) 00UP (H level)
 :3) 00UP (H level)
 :4) 0007
 :5) 0086
 :6) 0022
 :7) 0033
 :9) 00UP
 :10) 001P
 :11) 001F
 :12) 0000 (L level)
 :13) 0000 (L level)
 :14) 00UP (H level)
 :15) 00UP
 U13:5) 0030
 :6) 008P
 :7) 0038
 :9) 0080
 U17:2) 00FP
 U20:2) 0038
 :3) 00F6
 :5) 0038
 :6) 00FP
 :9) 00F6
 :11) 0038

② ADDRESS BUS

P1A3) UUUU
 :4) FFFU
 :5) 8487
 :6) P760
 :7) 1U5H
 :8) 0355
 :9) U75A
 :10) 6F99
 :11) 7792
 :12) 6322
 :13) 37C6
 :14) 6U2C
 :15) 4FC9
 :16) 486C
 :17) 9UP2
 :18) 0001

③ PROCESSOR FREE-RUN

U18(9) UUUU
 :10) FFFF
 :11) 8484
 :12) P763
 :13) 1U5P
 :14) 0356
 :15) U759
 :16) 6F9A
 :17) 7791
 :18) 6321
 :19) 37C5
 :20) 6U28
 :22) 4FCA
 :23) 4868
 :24) 9UP1
 :25) 0002

④ RAM/ROM Select Logic

U7(6) 328F
 U9(6) PACH
 U9(8) C72P
 U6(2) 9UP1
 U6(4) 0002

F Partial Data Bus Driver/Receiver Check

U4(1) 0000 (toggling)
 :2) PACH
 :3) PACH
 :4) 0003 (H level)
 :5) 0003 (H level)
 :6) PACP
 :8) 0003 (toggling)
 :9) PACP
 :10) 0000 (toggling)
 :11) 0003 (H level)
 :12) 0003 (toggling)
 :13) 0003 (H level)

G Data Bus Driver Logic

U6(8) 0000
 U6(9) 0003

H Data Bus Receiver Logic

U4(12) 00C3 (toggling)

I Data Bus Receiver/Drivers

U1(4) 5FC5
 :7) 0P30
 :9) 764P
 :12) CUHP
 U2(4) 0000 (toggling)
 :7) 594A
 :9) 0000 (toggling)
 :12) 1HHA

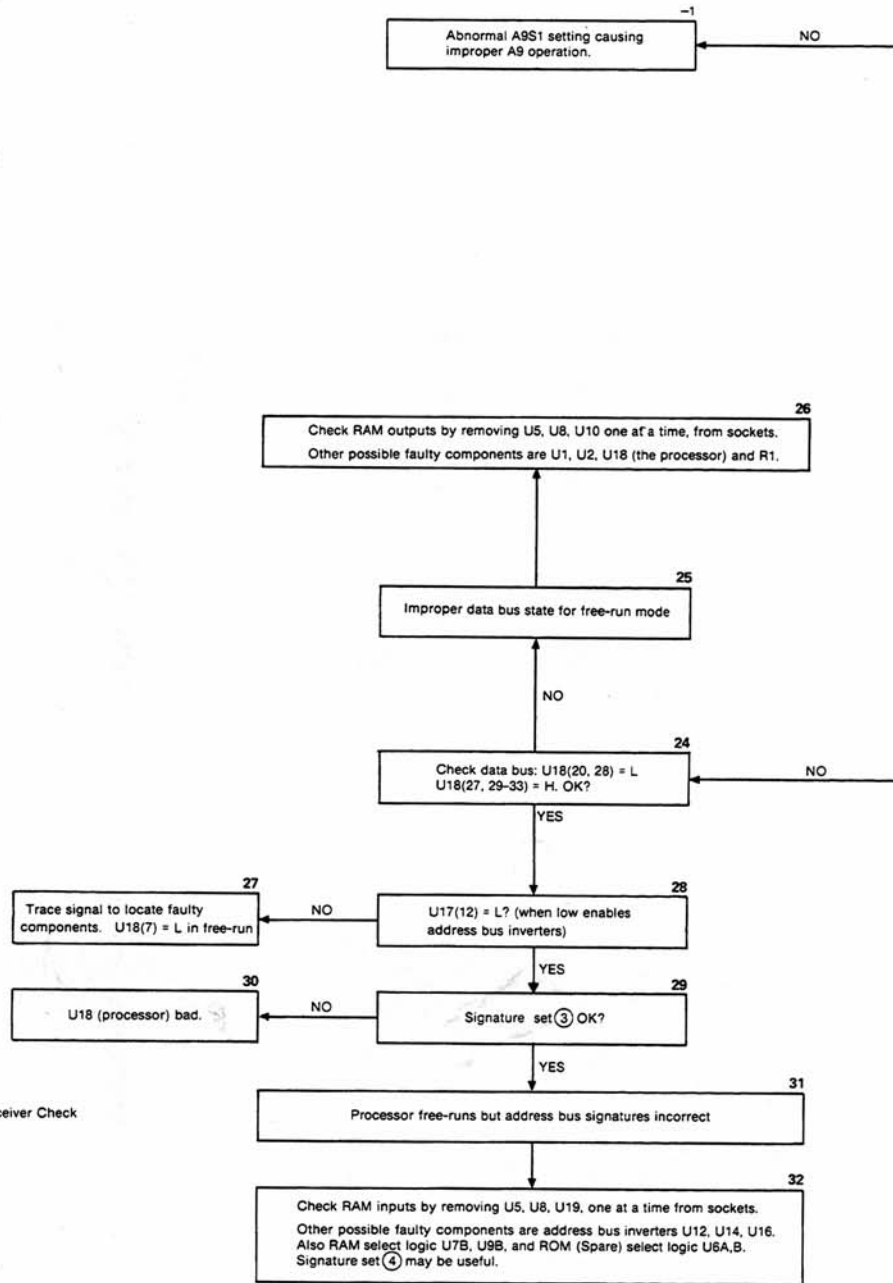

First part of page 8-57, which folds out.

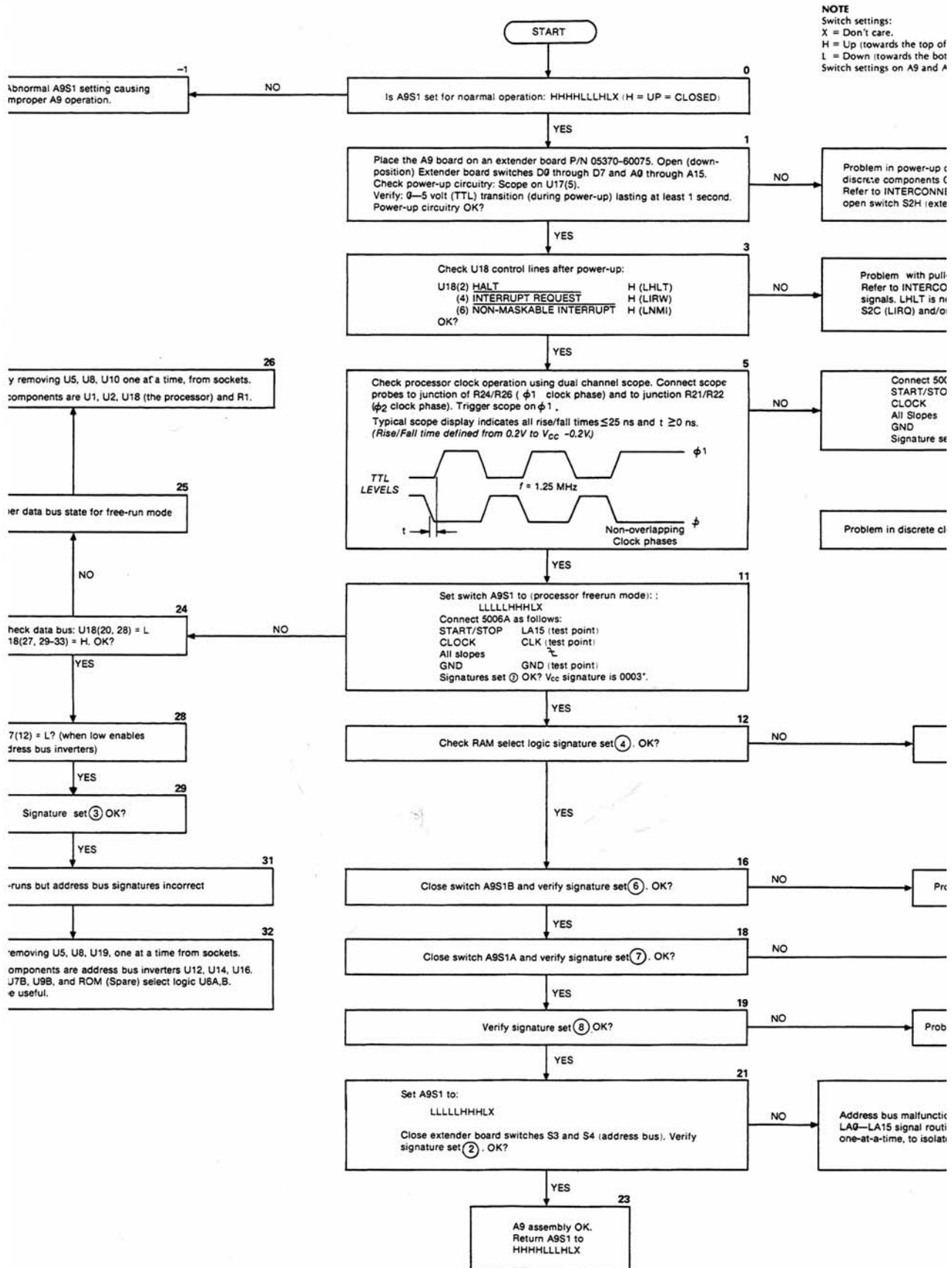

Second part of page 8-57, which folds out.

NOTE
Switch settings:
X = Don't care.
H = Up (towards the top of instrument).
L = Down (towards the bottom of instrument).
Switch settings on A9 and A16 are read from left to right.

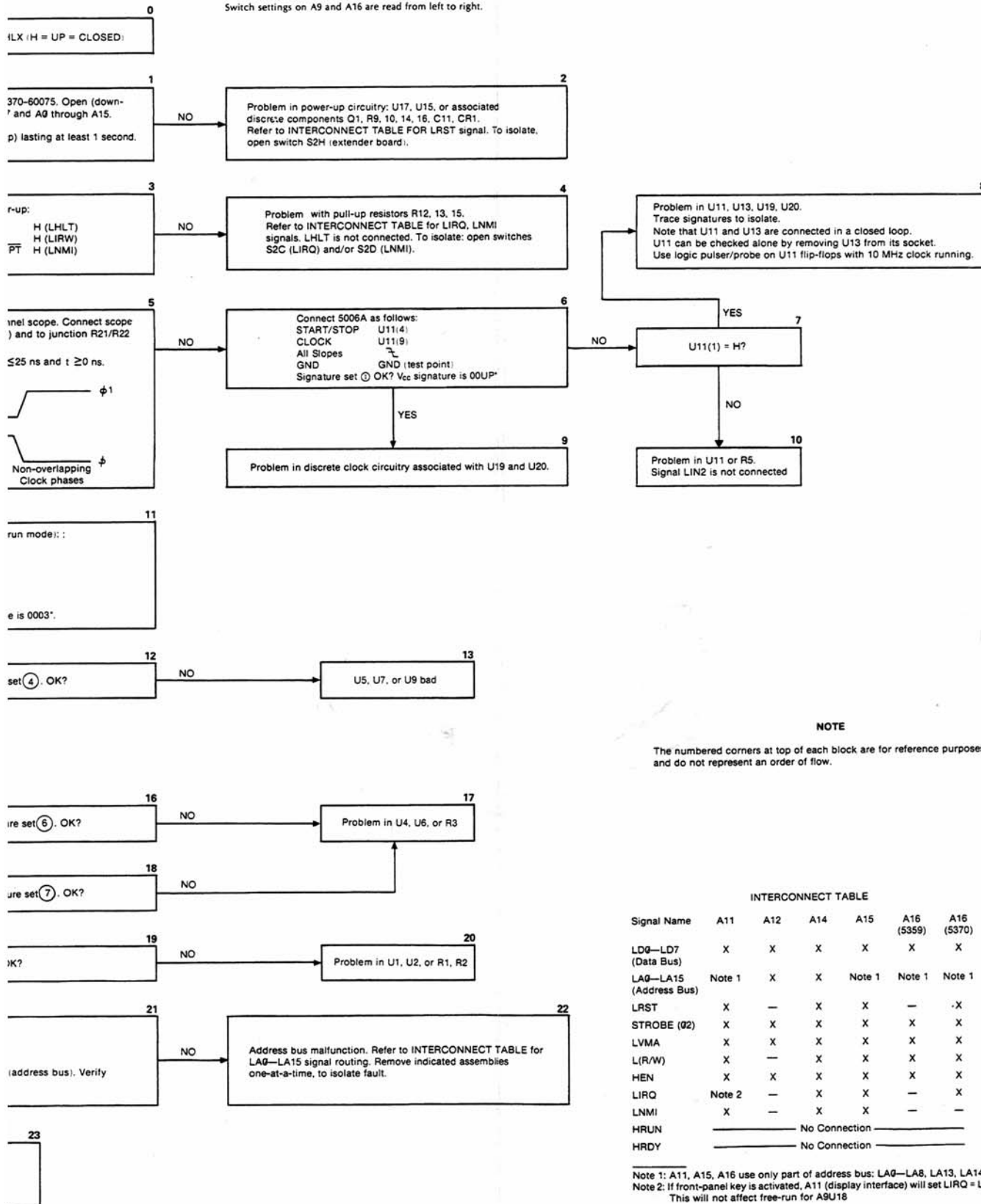
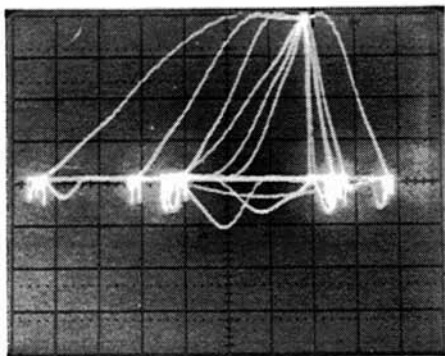
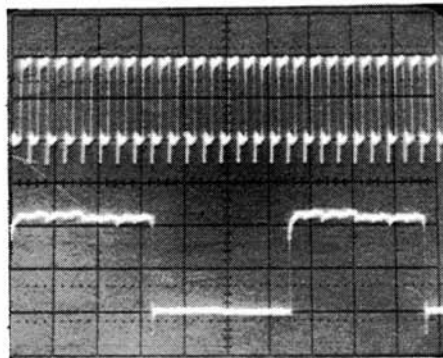

Figure 8-14. A9 Assembly Troubleshooting Flowchart

Third (and final) part of page 8-57, which folds out.



.02V/Div., 2 μ s/Div., 10:1 Probe



0.5V/div., 50 ms/div., 10:1 Probe

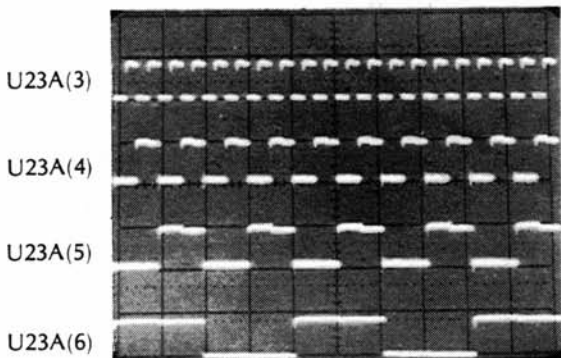

0.5V/div., 1 ms/div., 10:1 Probe

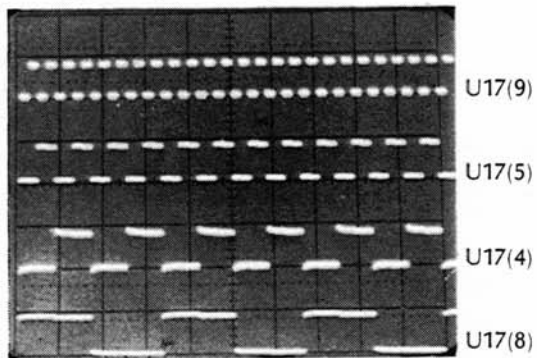

NOTE
 Switch settings:
 X = Don't care.
 H = Up (towards the top of in
 L = Down (towards the bottom
 Switch settings on A9 and A16

Sig set

- ① U15(8) 6177
 U18(6) 54C9
 U18(8) 839F
 U21(8) 1713

- ② U19(2) 14C3
 U19(8) AU96
 U19(12) C540
 U16(8) 8H4C
 U19(4) CA43
 U19(6) UU57
 U16(1) 576C

Input Lines (Check only if

- sig set ② is bad).**
 P1A(3) 9AH3
 P1A(4) 3HP0
 P1A(5) 50UA
 P1A(6) A2FF
 P1A(7) 366P
 P1A(8) 989P
 P1A(9) HH8A
 P1A(10) 2APF
 P1A(11) UCA2
 P1A(16) 3UP7
 P1A(17) 3UP7
 P1A(16) 22HH (High)
 P1A(2) 75C6
 P1A(11) 979H
 P1A(1) 22HH

- ③ U5(1) PHP8
 U5(2) 50UP
 U5(3) 7356
 U5(4) 36H2
 U5(5) PCH0
 U5(6) UP90
 U5(7) U51A
 U5(9) 0458

- U14(1) 464C
 U14(2) F5P3
 U14(3) 3H77
 U14(4) 8FH9
 U14(5) 65A4
 U14(6) 0H9U
 U14(7) UU68
 U14(9) 5UF6

- ④ U5(15) 5H21
 U5(14) 19H6
 U5(13) HP66
 U17(8) 7A70

- ⑤ U26(6) 78UH
 U26(8) 9PUP
 U24(12) U81P

- ⑥ U11(4) U81P
 U11(7) 5F08
 U11(9) 9CC8
 U11(12) HU4U

- ⑦ U11(4) 40HA
 U11(7) 11P2
 U11(9) PC16
 U11(12) FCPH

Input Lines (check only if sig set ⑦ is bad).

- U11(14) H283
 U11(11) U278
 U11(5) 088F
 U11(2) 59C4

- ⑧ U2(5) 721C
 U2(7) 15P2
 U2(11) CC77
 U2(9) CFF1
 U4(5) C757
 U4(7) 092U
 U4(11) 6H72

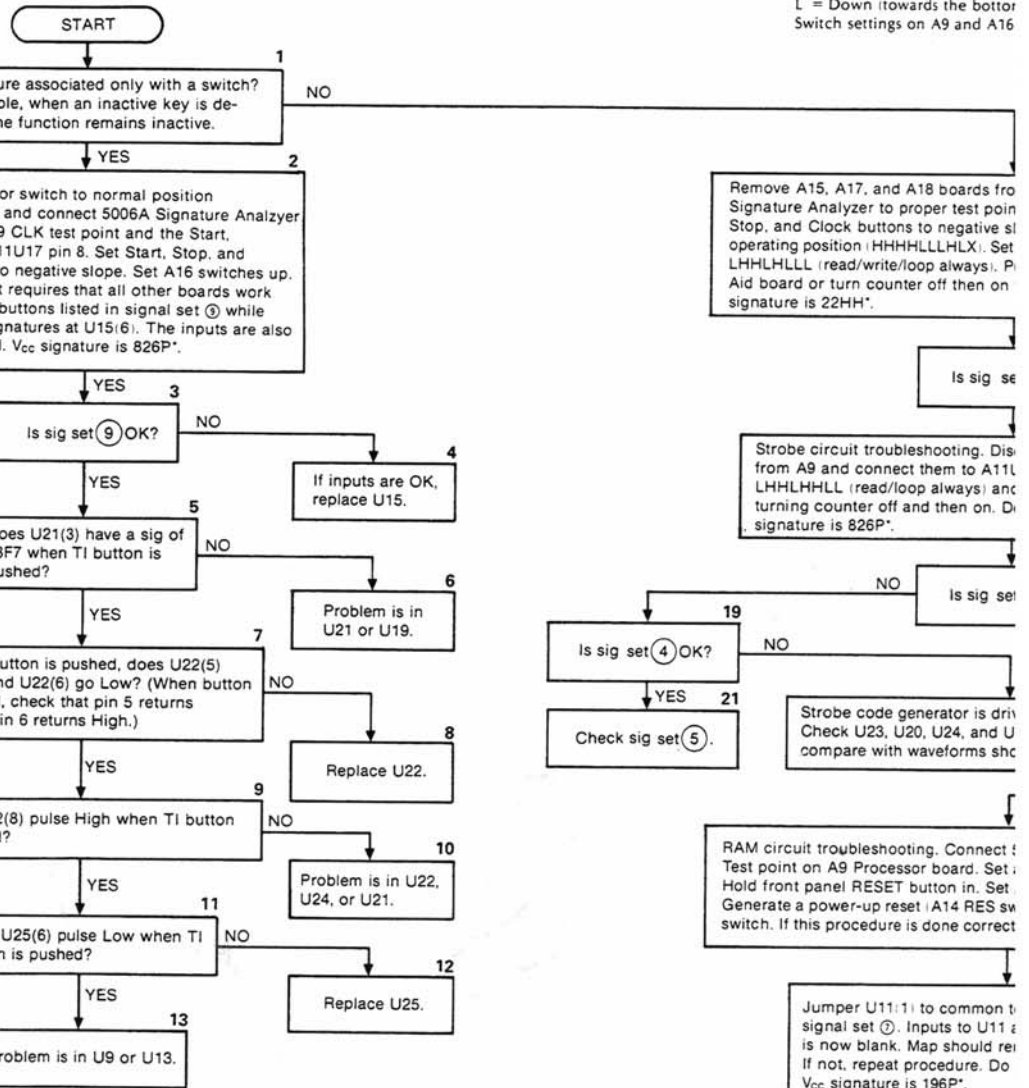

⑧ cont'd

- U4(9) 52A2
 U7(5) 243A
 U7(7) 2AA6
 U7(11) 6CUC
 U7(9) FFP8

⑨ KEY

- | KEY | IC | SIG |
|---------|--------|------|
| TI | U15(6) | 6U86 |
| PERIOD | U15(6) | H290 |
| DIS REF | U15(6) | U138 |
| SET REF | U15(6) | C4CF |

U15 Inputs (check only if sig set ⑨ is bad).

- | KEY | IC | SIG |
|---------|--------|------|
| TI | U15(4) | PHP8 |
| PERIOD | U15(5) | 50UP |
| DIS REF | U15(2) | 7356 |
| SET REF | U15(1) | 36H2 |

Remove Jumper. All lights on front in a "lamp test" condition. RAMs U2 for lighting the LED's.

The DD0—DD3 lines associated with segments a, b, c, and d.

The DD4—DD7 lines associated with segments e, f, g, and dp.

The LAN0—LAN3 lines associated with lighting all the pushbutton lamps and annunciators, except START and S1

NC

If any transistor on the anode strobe digit for that line will be blank.

NOTE
 Switch settings:
 X = Don't care.
 H = Up (towards the top of instrument).
 L = Down (towards the bottom of instrument).
 Switch settings on A9 and A16 are read from left to right.

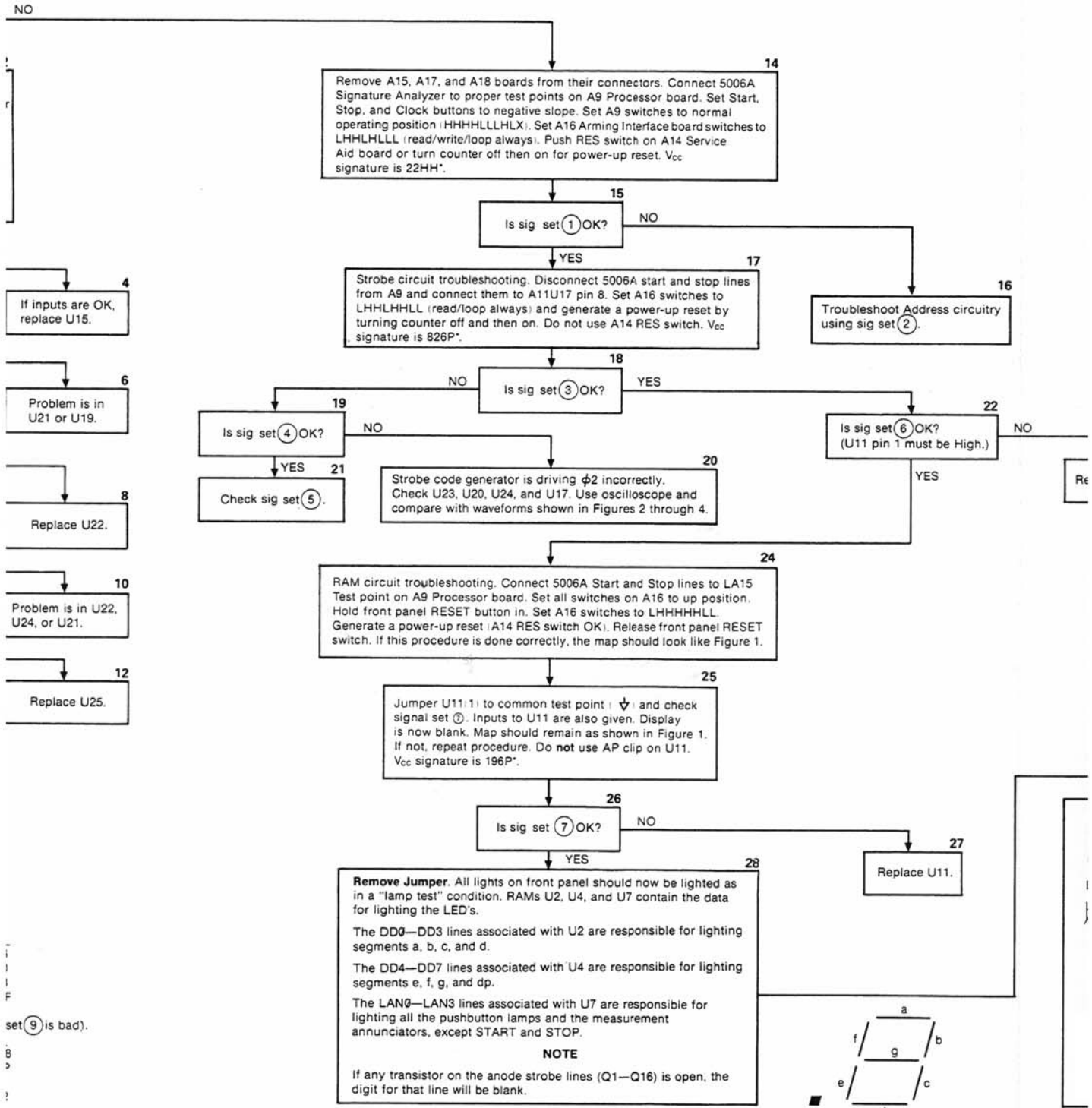

set (9) is bad).

Second part of page 8-59, which folds out.

is:
e.
rds the top of instrument).
wards the bottom of instrument).
i on A9 and A16 are read from left to right.

NOTE

The numbered corners at top of each block are for reference purposes and do not represent an order of flow.

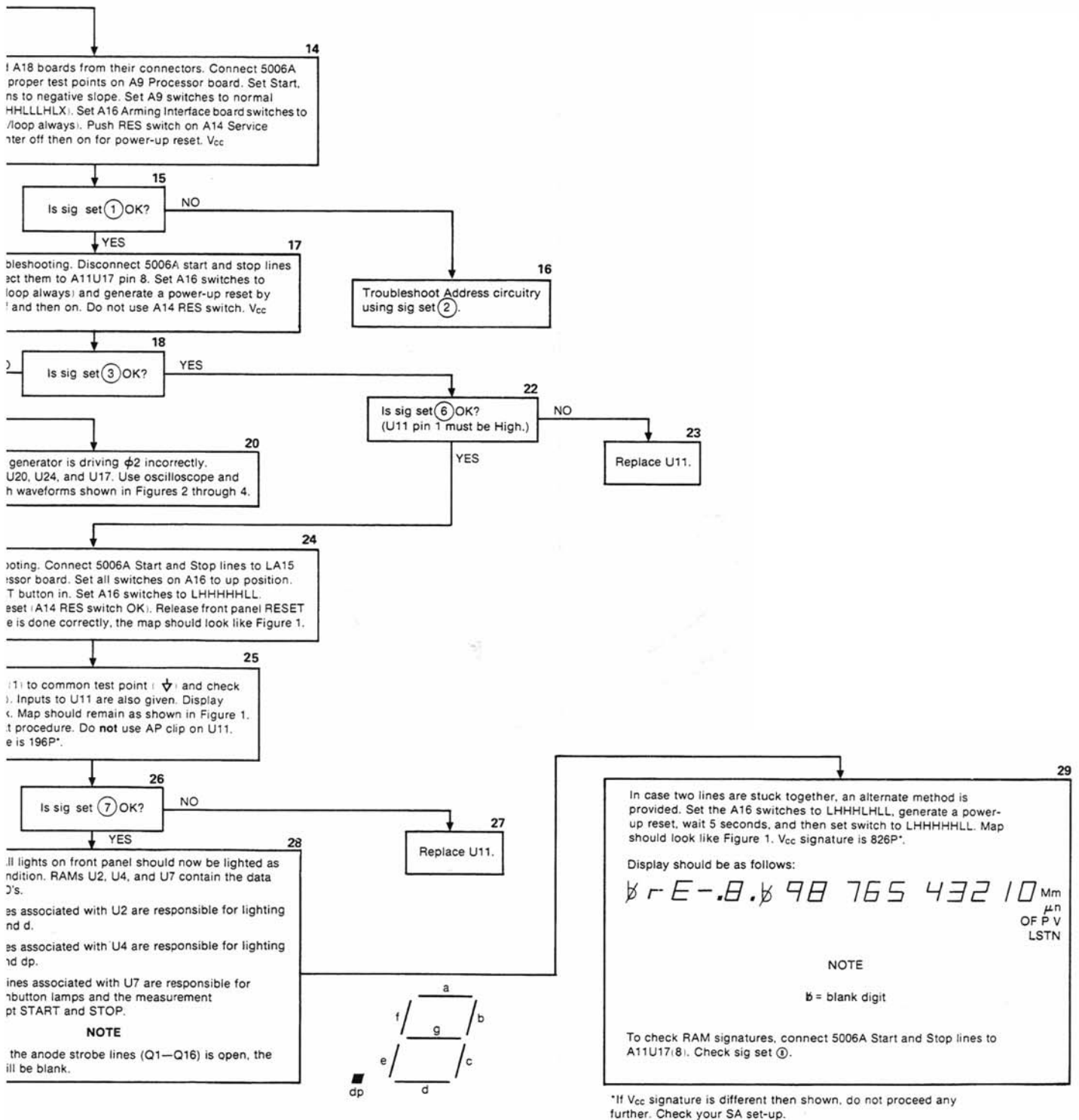

Figure 8-15. A11 Assembly Troubleshooting Flowchart

Sig set

- ① P1A(3) 4391
P1A(4) 7H7H
P1A(5) 9F79
P1A(6) FCHC
P1A(7) 41A9
P1A(8) 366H
P1A(9) 92CU
P1A(10) UA3H
- ② J1(1) 838A
J1(2) 6P57
J1(3) 294A
J1(4) 8PHF
J1(5) 87F3
J1(9) OF66
J1(10) A677
J1(11) 711U
J1(12) UUUUF
J1(13) 7242
J1(14) 1COH
J1(15) A137
J1(16) 1U8F
J1(17) 87F3
- ③ U10(8) 2A7H
P1B(8) 1H33
P1B(4) CP13
P1B(5) CP13
P1B(6) CP13
P1B(9) 22HH (High)
- ④ P1B(1) OFC1
P1B(2) 6U3F
P1B(3) 4AF7
P1B(4) 22HH (High)
P1B(1) 0278
P1B(2) 23P4
P1B(3) 93UU
P1B(5) 8286
- ⑤ U6(10) 14C3
U6(4) UU57
U6(2) 576C
U6(8) CS40
U8(6) HPHF
U8(12) 5HUA
U4(8) A6A7

Input Lines (check only if SIG set ⑤ is bad)

- P1A(3) 9AH3
- P1A(4) 3HP0
- P1A(5) 50UA
- P1A(6) A2FF
- P1A(7) 366P
- P1A(8) 989P
- P1A(9) HH8A
- P1A(10) 2APF
- P1A(11) UCA2
- P1A(16) 3UP7
- P1A(17) 3UP7
- P1A(16) 22HH (High)
- P1A(2) 75C6
- P1A(11) 979H
- P1A(18) 22HH (High)

- ⑥ U15(1) UUUUF
U15(15) 044H
U17(15) PP07

- ⑦ U6(10) 1U5P
U6(4) U759
U6(2) 0003 (High)
U6(8) 0003 (toggling)
U8(6) 0003 (High)
U8(12) 1U5H
U4(8) A0U8
U14(13) PP07
U14(12) P043
U14(11) 0407
U14(10) 4047
U14(9) 044H
U14(7) 44PF

Sig set

- ⑧ P1A(3) 5415
P1A(4) 5415
P1A(5) 5415
P1A(6) 665A
P1A(7) 5415
P1A(8) 044H
P1A(9) 505C
P1A(10) 0003 (High)

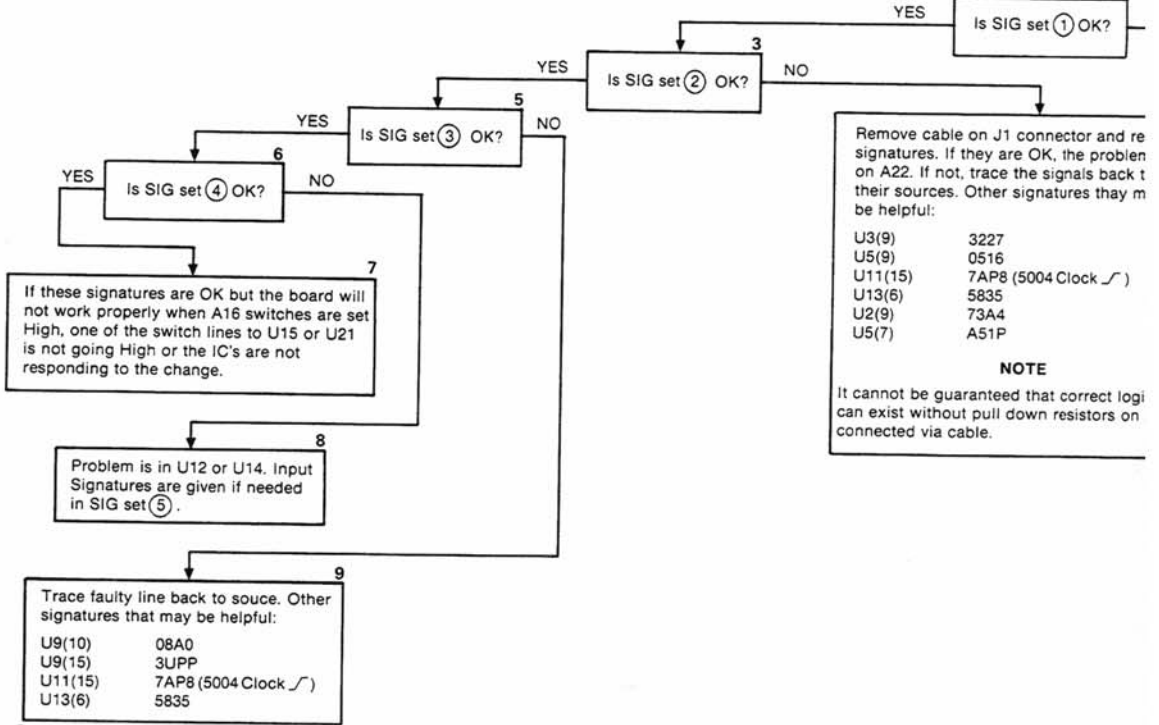

Input Lines (Check only if SIG set ⑦ is bad)

- P1A(3) UUUUF
- P1A(4) FFFU
- P1A(5) 8487
- P1A(6) P760
- P1A(7) 1U5H
- P1A(8) 0355
- P1A(9) U75A
- P1A(10) 6F99
- P1A(11) 7792
- P1A(16) 486C
- P1A(17) 9UP2
- P1A(16) 0003 (High)
- P1A(2) 0000 (Low)
- P1A(11) 0000 (Low) May indicate toggling
- P1A(18) 0003 (High)

NOTE

The numbered corners at top of each block are for reference purposes and do not represent an order of flow.

P1A(3) 5415
 P1A(4) 5415
 P1A(5) 5415
 P1A(6) 665A
 P1A(7) 5415
 P1A(8) 044H
 P1A(9) 505C
 P1A(10) 0003 (High)

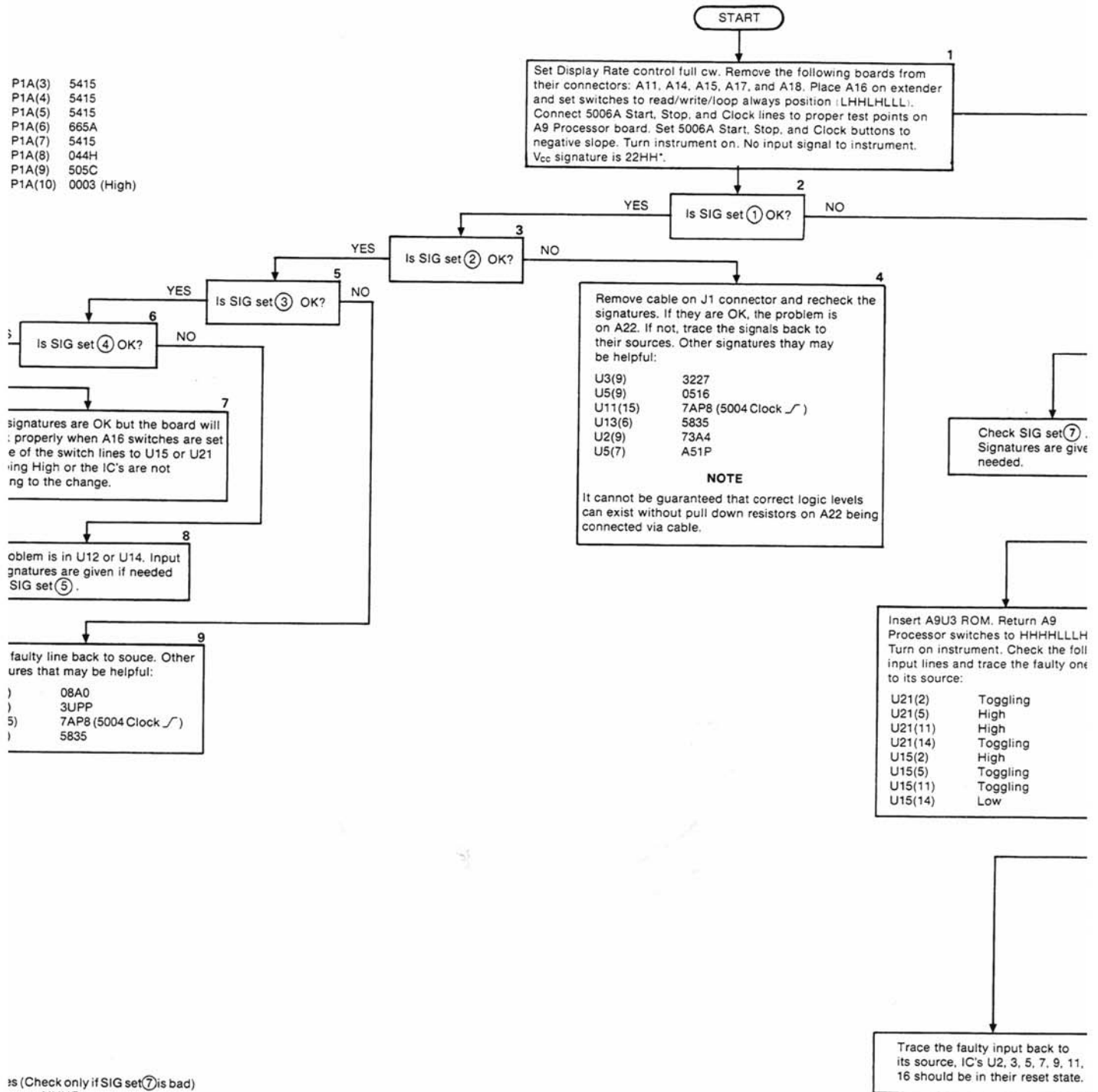

is (Check only if SIG set (7) is bad)

UUUF
FFFU
8487
P760
1U5H
0355
U75A
6F99
7792
486C
9UP2
0003 (High)
0000 (Low)
0000 (Low) May indicate toggling
0003 (High)

NOTE

The numbered corners at top of each block are for reference purposes and do not represent an order of flow.

NOTE
Switch settings:
X = Don't care.
H = Up (towards the top of instrument).
L = Down (towards the bottom of instrument).
Switch settings on A9 and A16 are read from left to right.

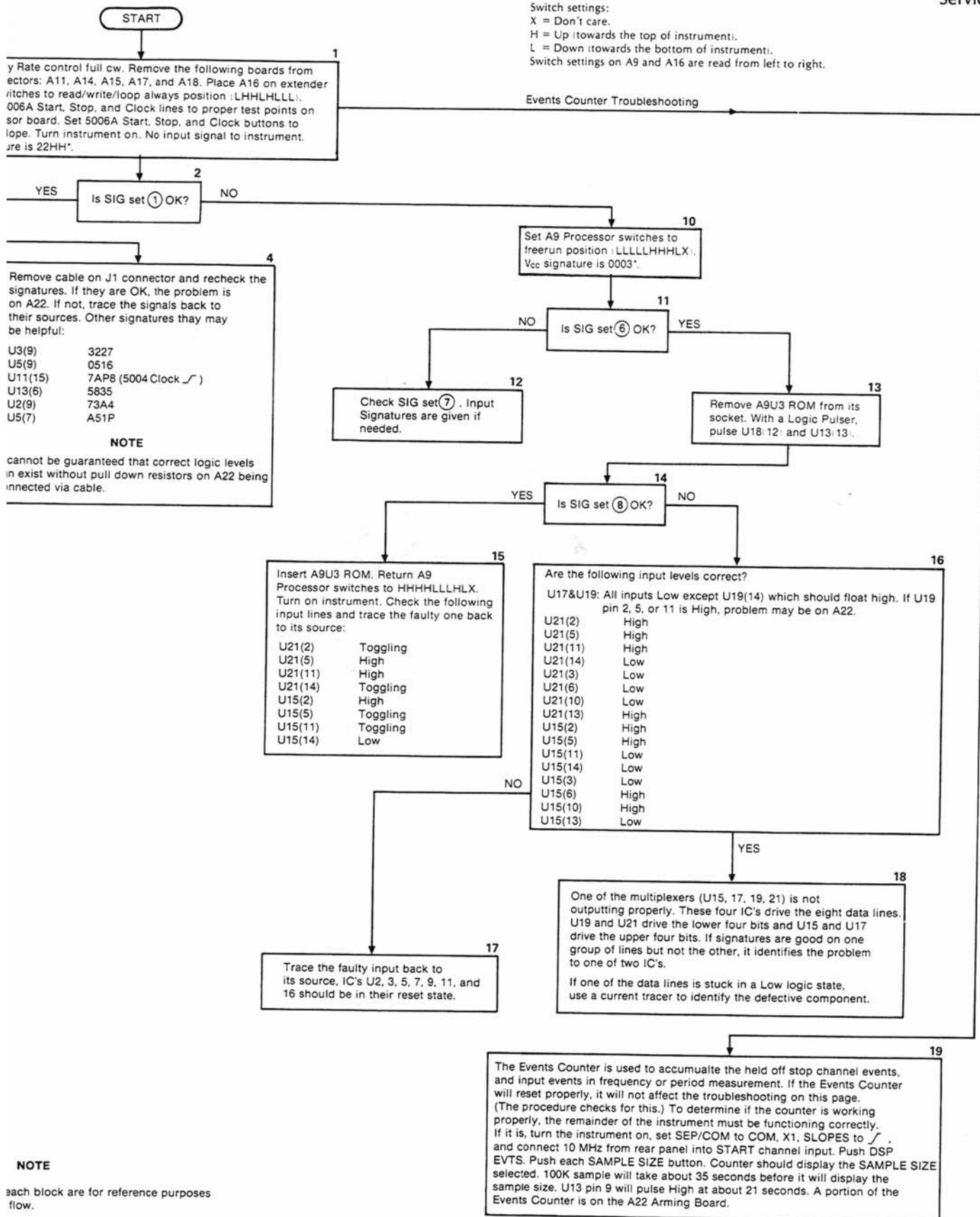
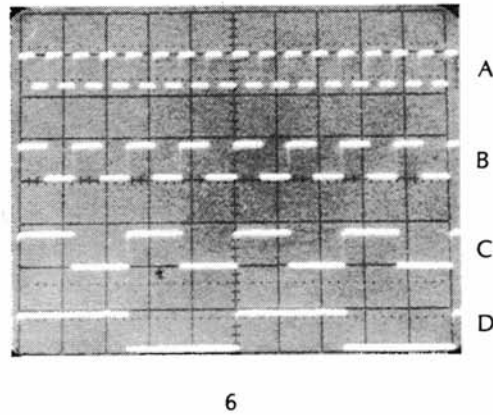
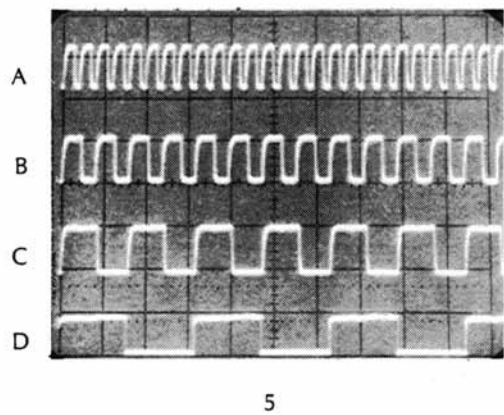
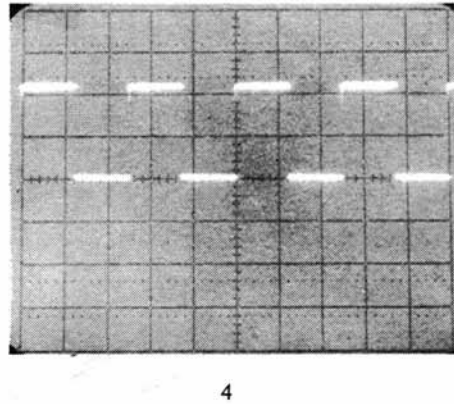
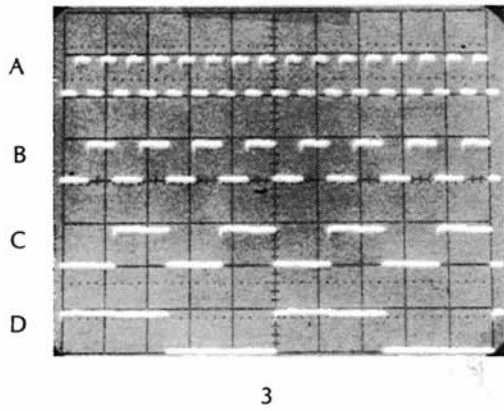
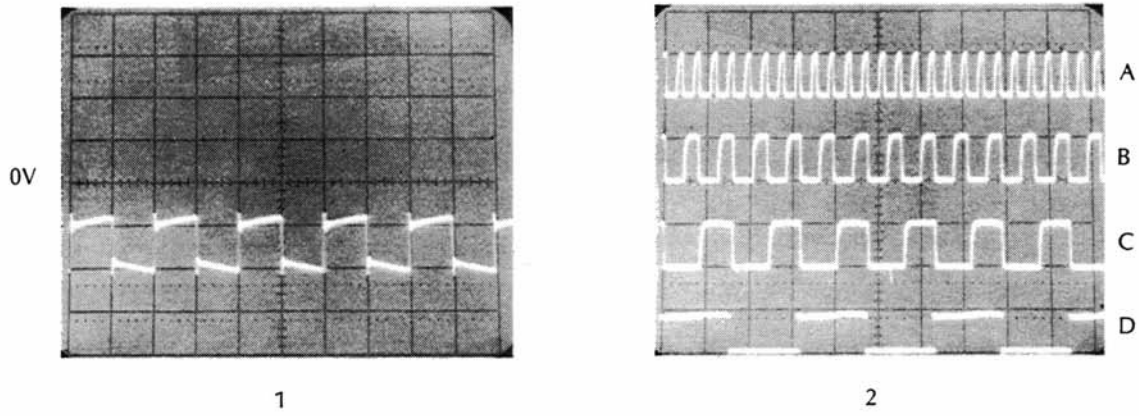
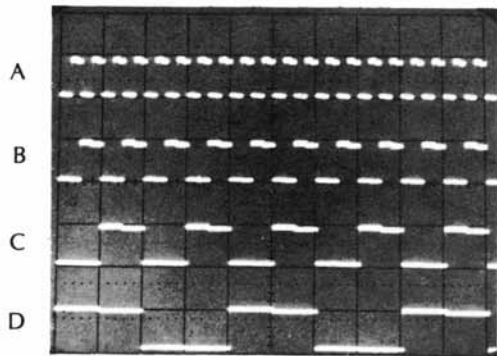

Figure 8-16
A16 ASSEMBLY TROUBLESHOOTING FLOWCHART

Third (and final) part of page 8-61, which folds out.



Part of Figure 8-17. A17 Assembly Troubleshooting Flowchart



7

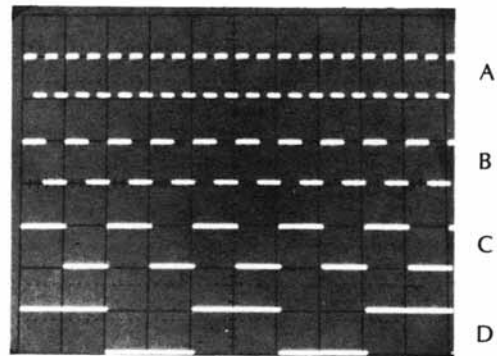

8

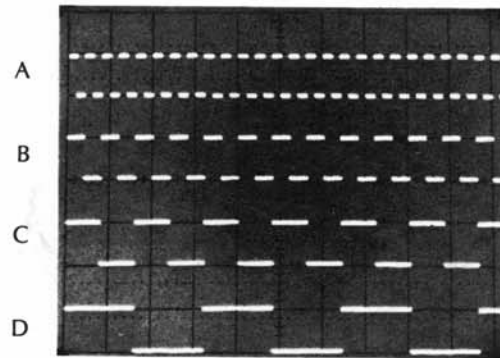

9

First part of page 8-63, which folds out.

NOTE

Before changing any part, it is advisable to pulse U14(9) and/or U11(14) and reread the signature. (Noise pulses generated by probing or movement of electrical connections can affect the counter circuits.)

Sig set

① U12(4) 2U1H
U12(7) P17U
U12(9) 5PC3
U12(12) 6570

② U12(2) 556H
U12(5) 9C0U
U12(11) 24F3
U12(14) 1U00

③ U8(4) 8299
U8(7) 1U1A
U8(9) 2H8H
U8(12) FU73

④ U8(2) U8P9
U8(5) 656A
U8(11) 57UH
U8(14) C503

⑤ U12(4) 8114
U12(7) 0AH2
U12(9) 4499
U12(12) 81UH

⑥ U12(3) UC64
U12(6) 70A2
U12(10) 3PP9
U12(13) UC8H

⑦ U15(6) AP09
U15(2) 61HF

NOTES

1. The numbered corners at the top of each block are for reference purposes and do not represent an order of flow.
2. The counter circuits on the left of the schematic are ECL. Most of the level translation is done with the aid of resistor circuits. The translation is not complete until the signal has passed through the entire circuit.
3. Most of the figures in this procedure show waveforms on a four-channel oscilloscope. The purpose is to show the timing relation. This is not necessary in troubleshooting. Waveforms may be examined individually for proper amplitude and period.

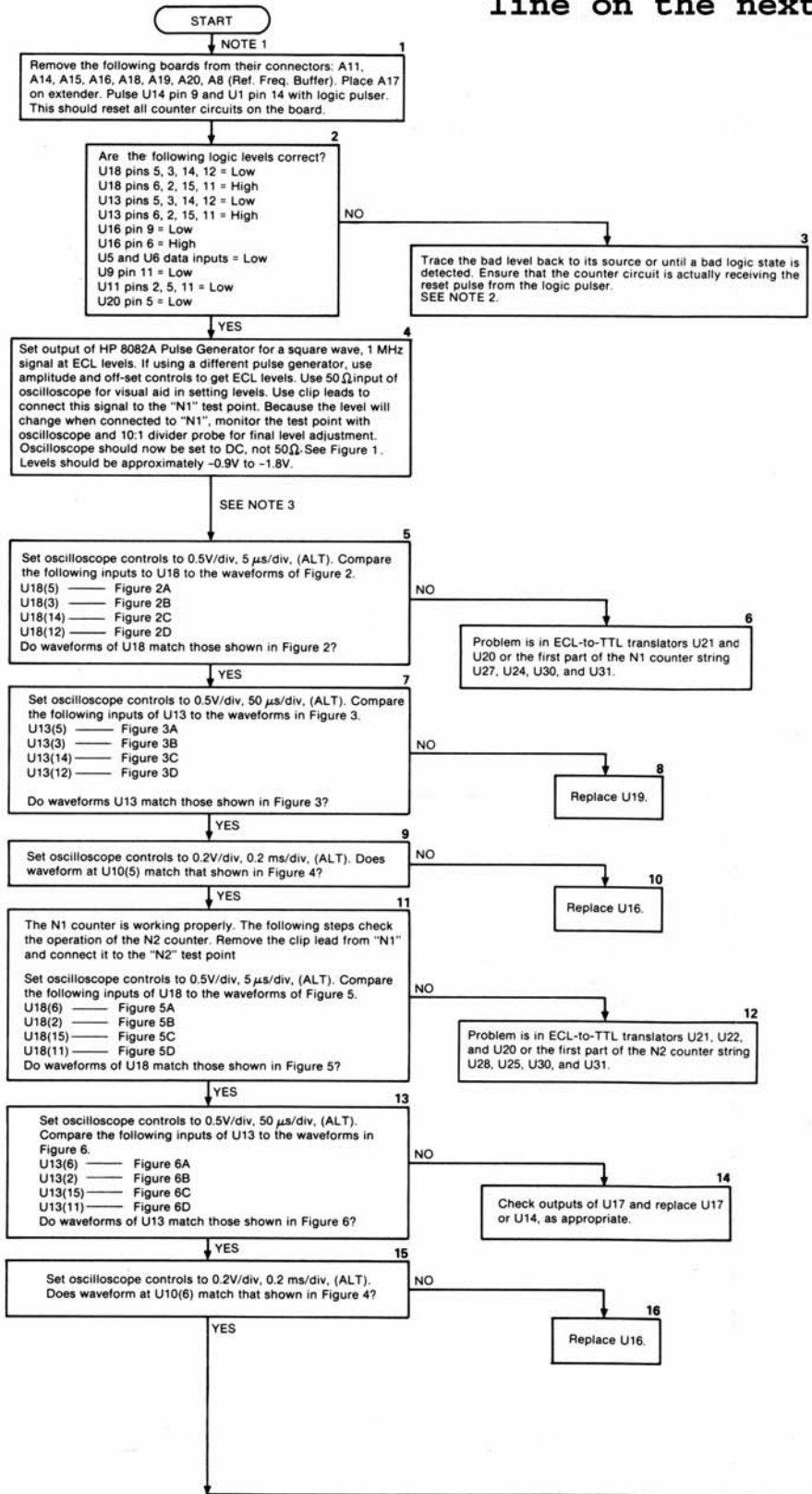

Second part of page 8-63 which folds out.

This line joins to the line
on the previous page

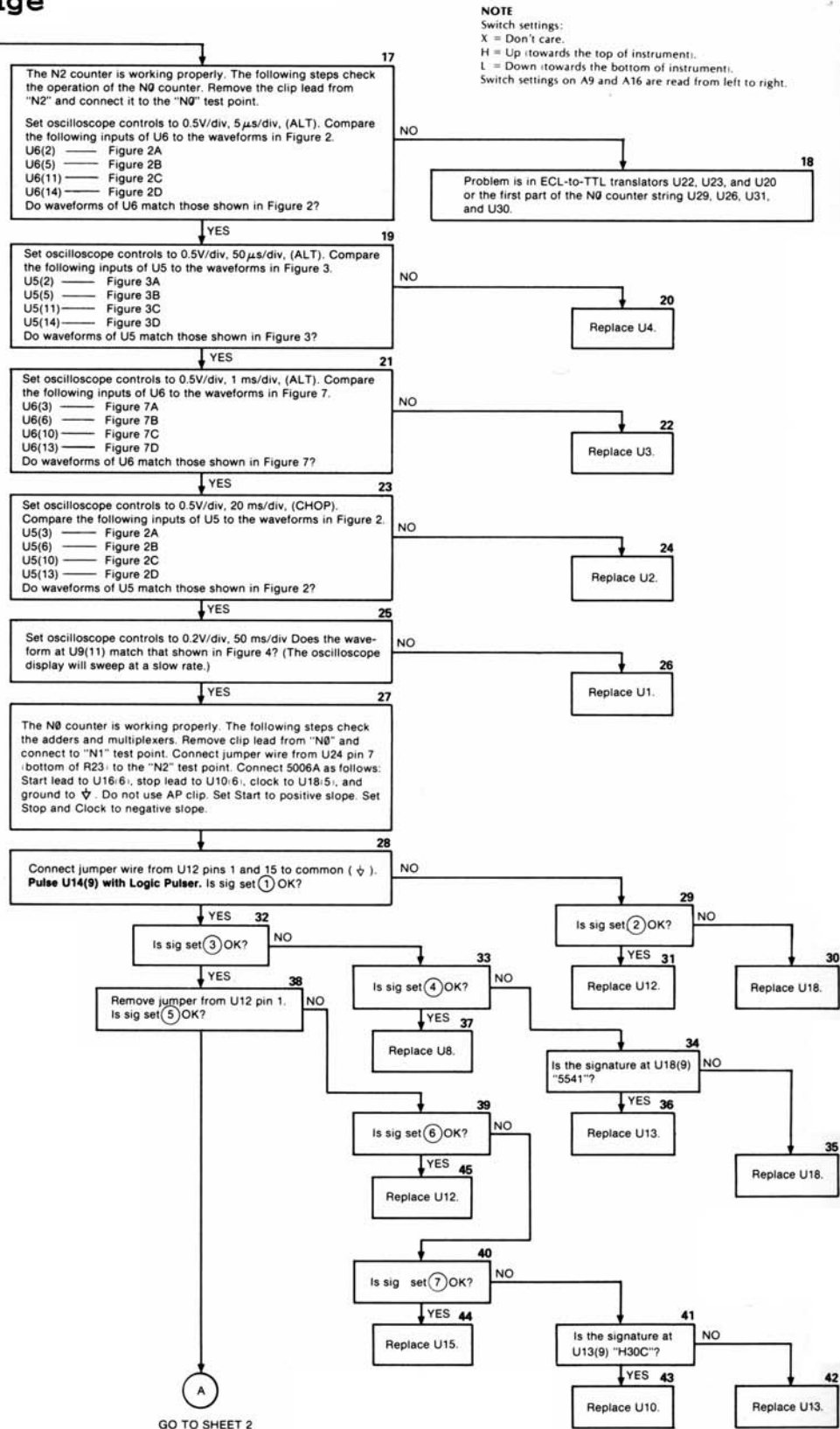

Figure 8-17. A17 Assembly Troubleshooting Flowchart

Third (and final) part of page 8-63, which folds out. (Sheet 1 of 2)
Sheet 2 of 2 is on page 8-85.

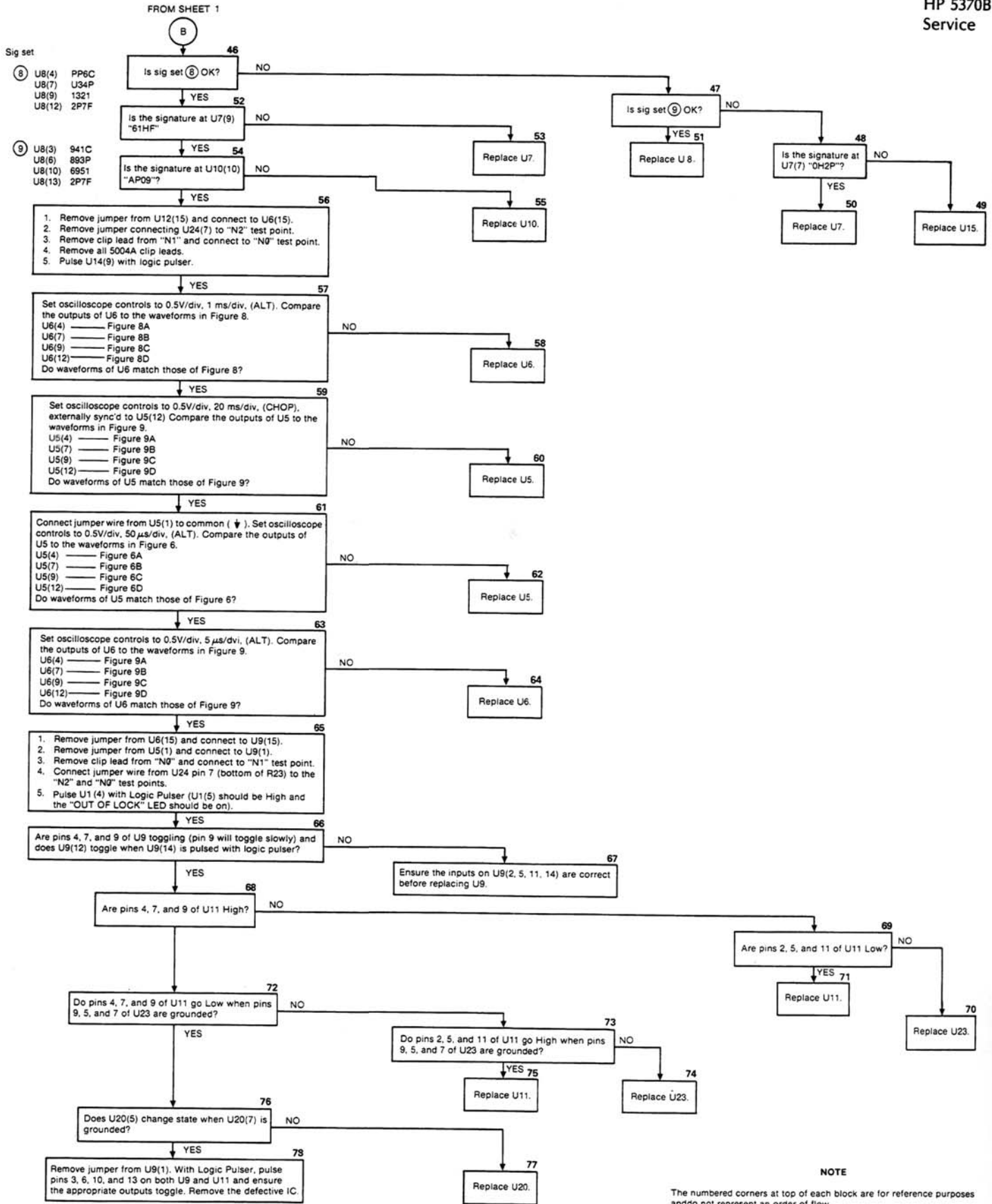

Figure 8-17. A17 Assembly Troubleshooting Flowchart
(Sheet 2 of 2)

8-268. Place oscilloscope probe on TP9. Push the start channel slope switch down and then up. This action should set the flip-flops such that N0 pulses (200 MHz) are present at TP9. If N0 pulses are present, the count chain circuits will overflow after about 10 seconds and an error 02 message will be displayed on the front panel. To repeat the test, push RESET and toggle the start slope switch again, then proceed to the next test. If the N0 pulses are *not* present, check the following static ECL levels during the 10-second period. (One way to overcome the 10-second limitation is to ground TP9.)

U17(2)	High	U16(15)	Low
U17(3)	Low	U18(2)	Low
U17(15)	Low	U18(3)	Low
U17(14)	High	TP9	200 MHz (not grounded)
U16(2)	High	TP11	High
U16(3)	Low		

8-269. Once the start channel has been triggered, using the stop slope switch to trigger, the stop channel will pulse the circuit back to its original state. To check this, set oscilloscope to 2 ms/div. and monitor TP11 while repeating the procedure of using the start and stop slope switches. TP11 should pulse low, although it may not be possible to see it every time. If the pulse appears at TP11, go on to the +T.I. troubleshooting. However, if the pulse is *not* present, the circuit can be checked statically by the following method: jumper TP11 to common (TP15), push RESET, toggle the start and stop slope switches *once*, check the following points:

U17(2)	High	U16(3)	Low
U17(3)	Low	U16(15)	High
U17(15)	High	U18(2)	Low
U17(14)	Low	U18(3)	High
U16(2)	Low	TP9	Low
		TP12	High

8-270. N0 Logic Static Troubleshooting for +T.I. Arming

8-271. Before beginning this troubleshooting, ensure that the circuit works properly in +T.I. ONLY, then proceed as follows. With all boards installed and no input signal, set both slope switches to the \mathcal{F} position and turn power on. Push +T.I. If START light comes on, push PERIOD COMPLMNT to get STOP light. Connect oscilloscope of at least 200 MHz bandwidth to TP9 and toggle the stop channel slope switch twice. This action should set the flip-flops such that N0 pulses (200 MHz) are present at TP9. (The pulses may appear after the first toggle of the slope switch.) TP12 should be low for minus sign.

8-272. If the N0 pulses are present, the count chain circuits will overflow after about 10 seconds and an error 02 message will be displayed on the front panel. To repeat the test, push RESET, and toggle the stop slope switch again, then proceed to the next test. If the N0 pulses are *not* present, check the following static ECL levels during the 10-second period. (One way to overcome the 10-second limitation is to ground TP9.)

U17(2)	Low	U16(3)	High
U17(3)	High	U16(15)	Low
U17(15)	High	U18(2)	Low
U17(14)	Low	U18(3)	Low
U16(2)	Low	TP9	200 MHz (not grounded)
		TP12	Low

8-273. Once the stop channel has been triggered, using the start slope switch to trigger the start channel will pulse the circuit back to its original state. To check this, set oscilloscope to 2 ms/div.,

and monitor TP11 while repeating the procedure using the stop and start slope switches. TP11 should pulse Low, although it may not be possible to see it every time. If the pulse is *not* present, the circuit can be checked statically by the following method: jumper TP11 to common, push RESET, toggle the stop and start slope switches as previously mentioned, and check the following points.

U17(2)	High	U16(3)	Low
U17(3)	Low	U16(15)	High
U17(15)	High	U18(2)	Low
U17(14)	Low	U18(3)	High
U16(2)	Low	TP9	Low
		TP12	Low

8-274. A19/A20 START/STOP INTERPOLATOR TROUBLESHOOTING

8-275. The A19 and A20 assemblies are identical. This troubleshooting information applies directly to both. Before troubleshooting either assembly, place the defective assembly on an extender board (i.e., 05370-60077 extender board found in the 10870A service accessory kit).

8-276. The first five wave shapes were photographed without a signal applied to the front end and the 5370B power-up conditions set. The remaining photographs were taken with a 10 MHz signal input supplied from the rear panel 10 MHz output jack.

NOTE

Equipment: HP 1725A Oscilloscope
HP 10013A 10:1 Oscilloscope Probe

The oscilloscope settings are shown above each photograph. With the 5370B power ON and the defective A19 or A20 assembly on an extender board, observe the following five wave shapes at the designated points:

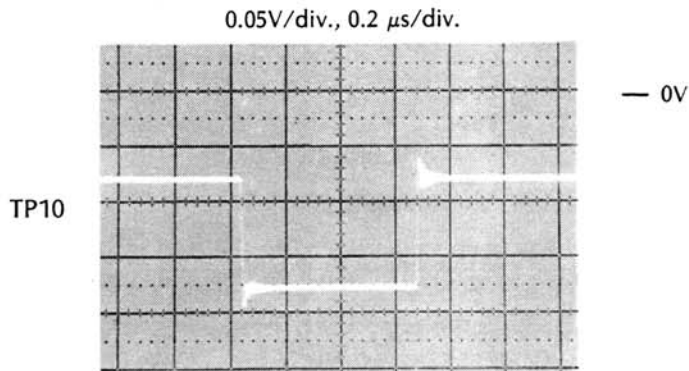
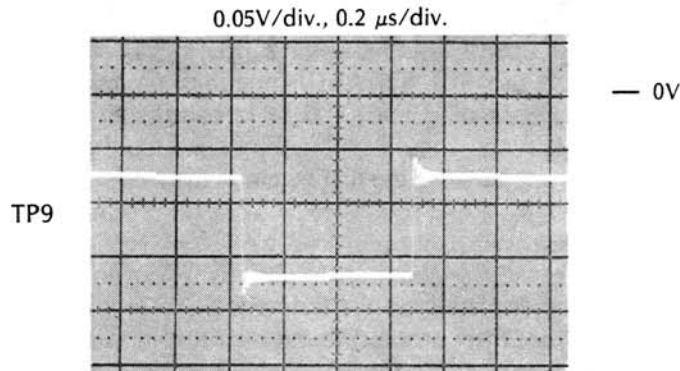

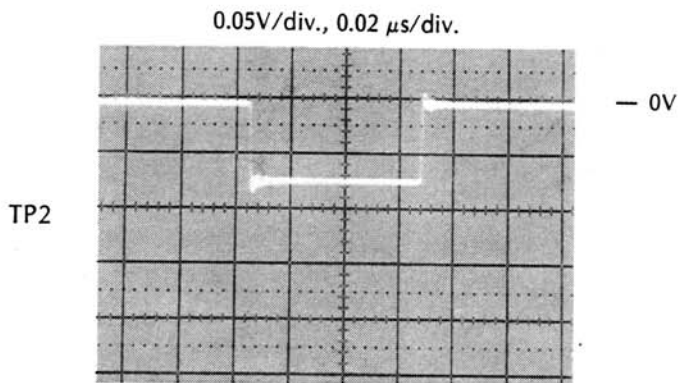
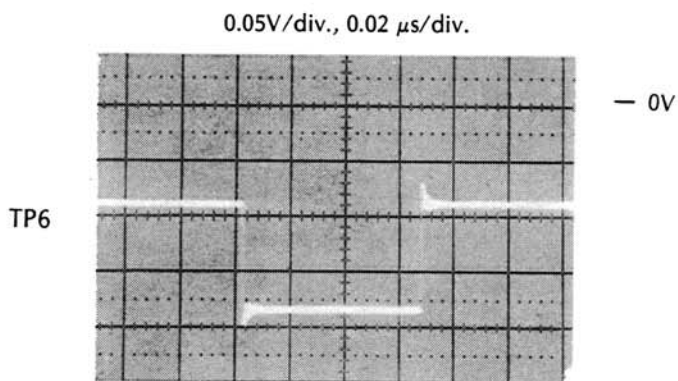
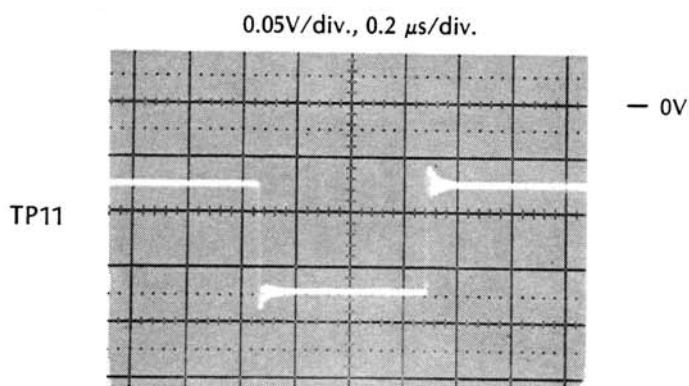

To observe the remaining wave shapes

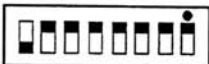
1. Connect a coax cable from the rear panel 10 MHz output to the front panel START input.
2. Set the switches on the A16 Arming Interface assembly as follows: 
3. Set the 5370B front panel input switches as follows:

BOTH CHANNELS
 IMPEDANCE 50 Ω
 ATTENUATION +1
 COUPLING DC
 SLOPES \mathcal{F}
 START COM/SEP START COM

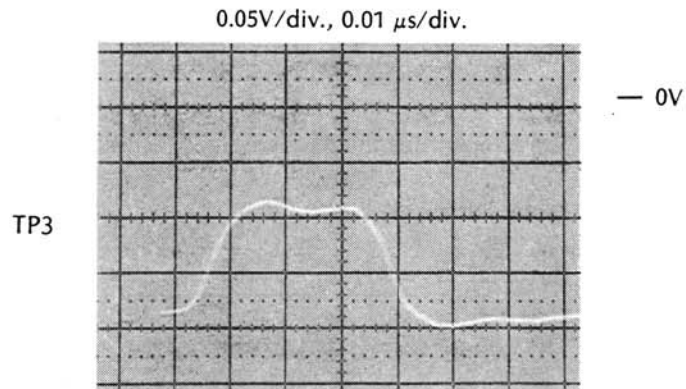
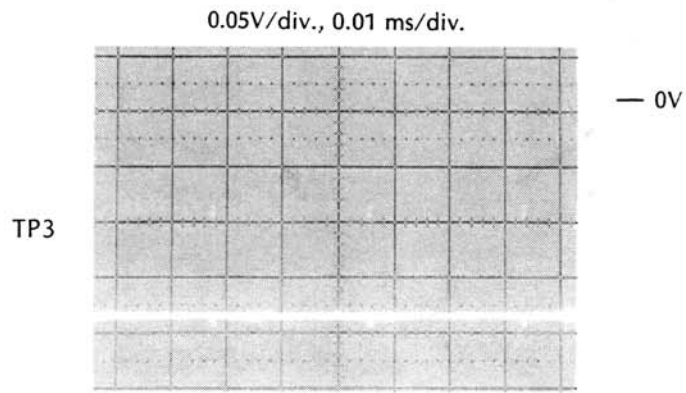
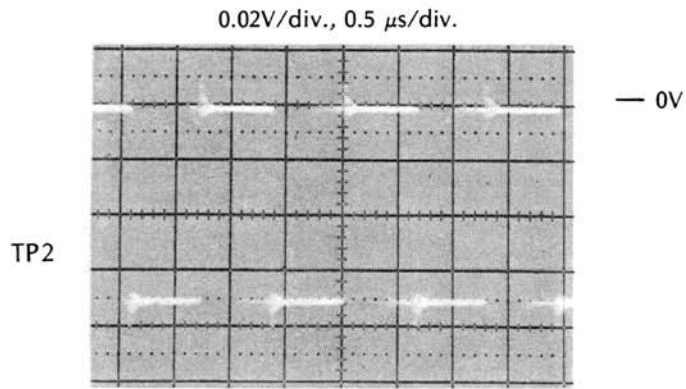
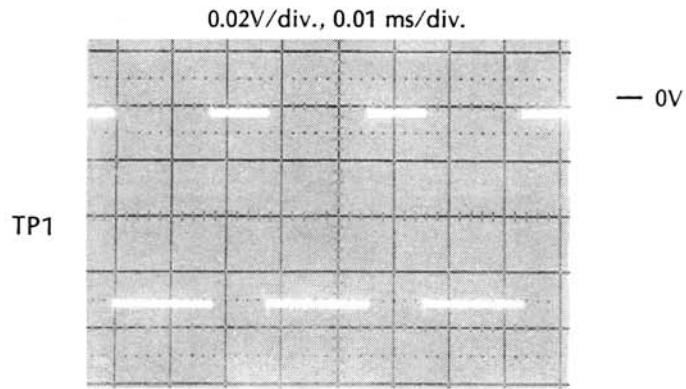

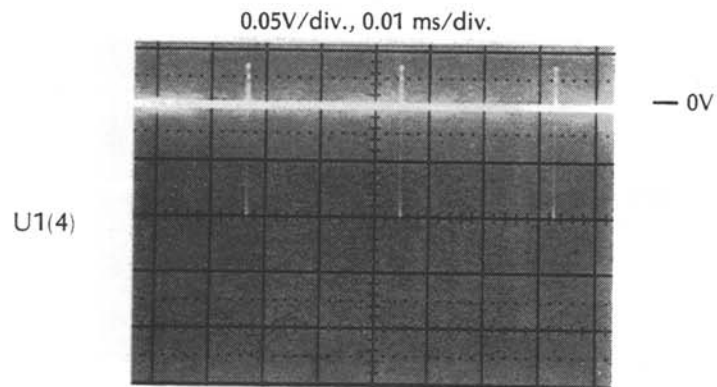
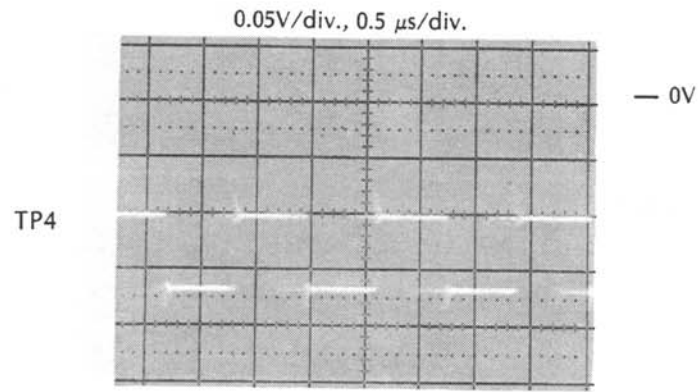

Oscilloscope Main Triggering \pm

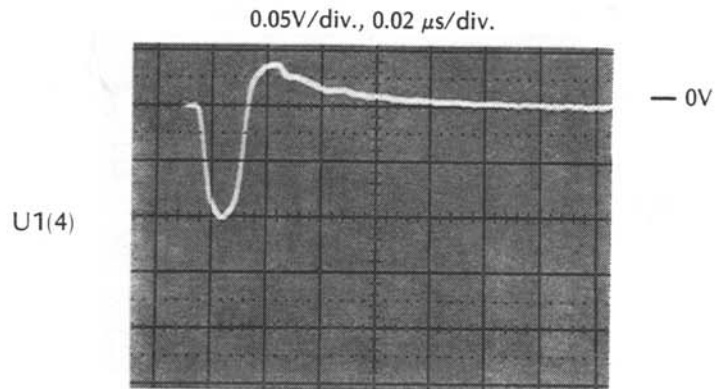

Oscilloscope Main Triggering \pm

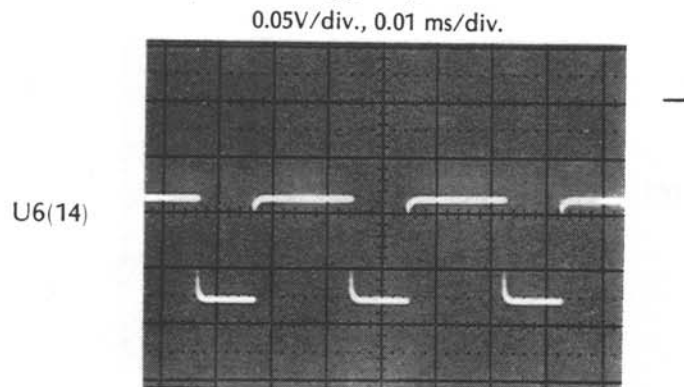

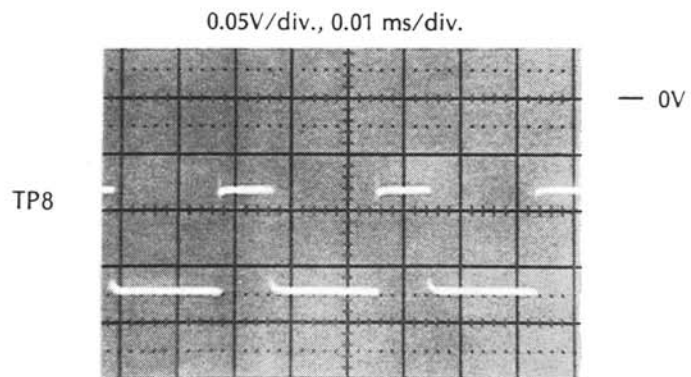
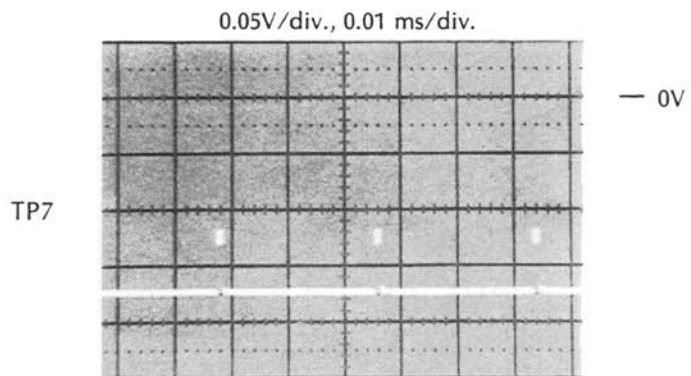
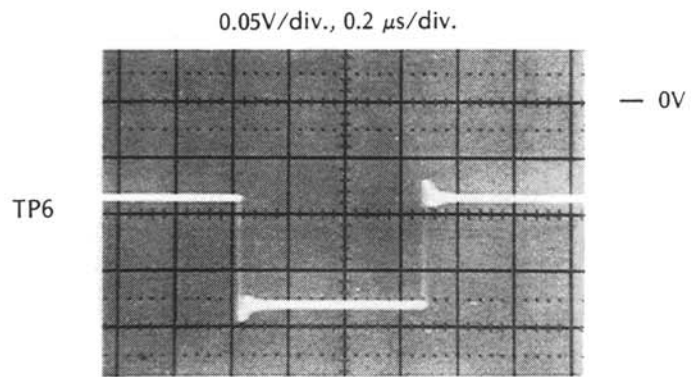
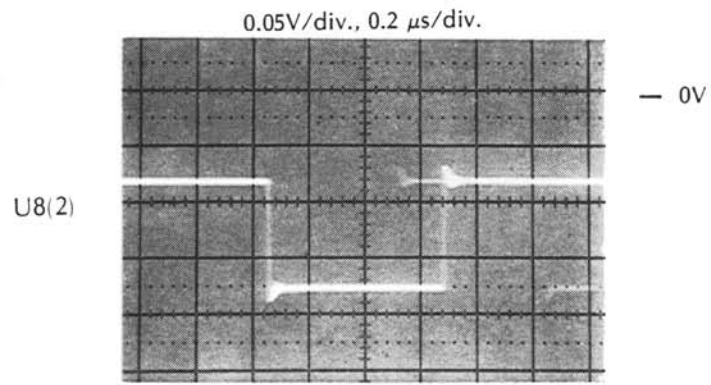

8-277. A21 200 MHz MULTIPLIER TROUBLESHOOTING

8-278. Begin troubleshooting the A21 assembly by placing the assembly on an extender board (i.e., 05370-60077 extender board found in the 10870A service accessory kit). The following five photos show wave shapes which appear at designated points throughout the circuit. All wave shapes were taken using an HP 1725A (275 MHz) oscilloscope and 10020A resistive dividers with a 20:1 tip. No special 5370B front panel setup is necessary.

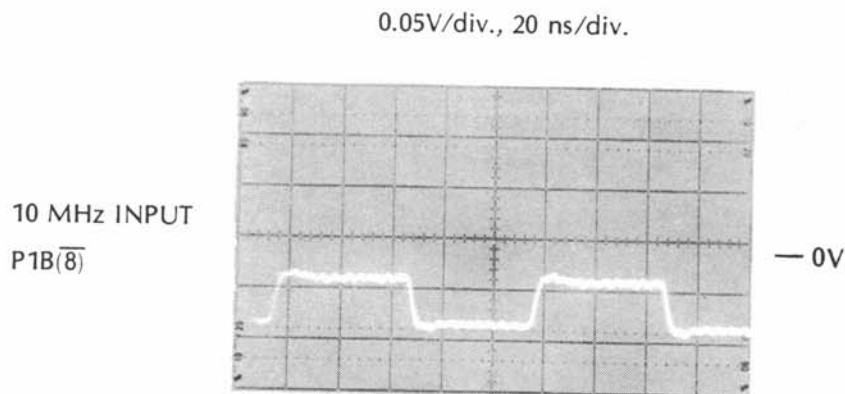
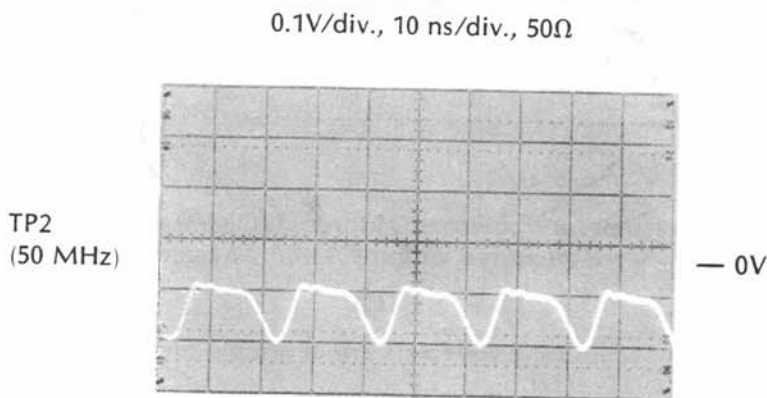
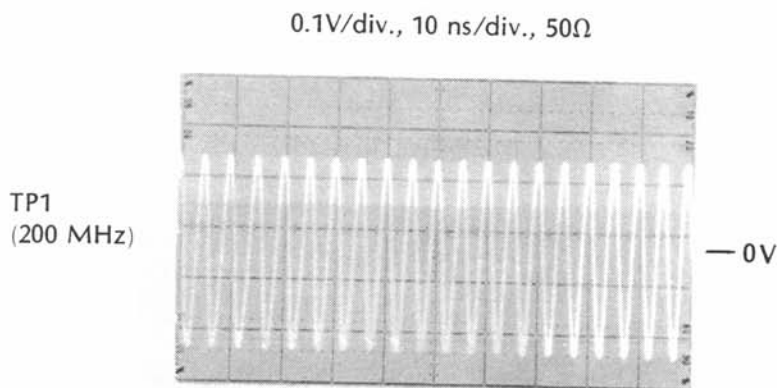

0.02V/div., 10 ns/div.

U2A(3, 15)

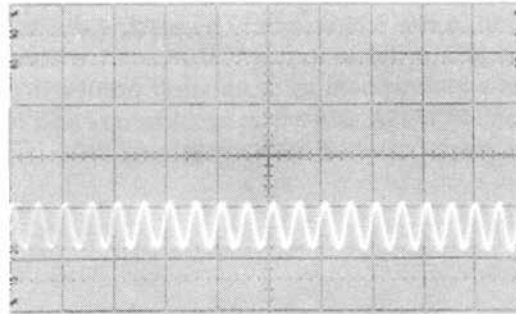

0V

0.02V/div., 10 ns/div.

200 MHz
U1(14)
U1(2)

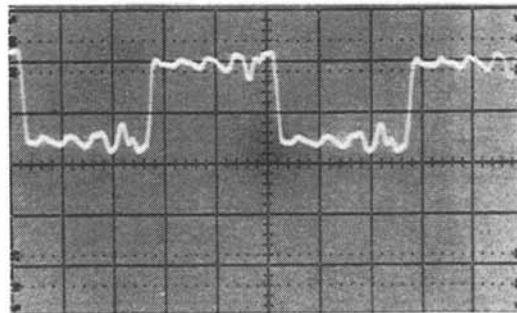

0V

The following dc bias voltages for transistors Q1 through Q8 were measured with an HP 3465A Digital Multimeter. They were measured with the 5370B A8 assembly removed.

NOTE

All of the collectors are at ground (0V).

	Base	Emitter
Q1	-14.9V	-15.0V
Q2	-12.0V	-12.7V
Q3	-7.9V	-8.5V
Q4	-8.5V	-9.1V
Q5	-7.6V	-8.2V
Q6	-7.5V	-8.1V
Q7	-7.6V	-8.2V
Q8	-7.5V	-8.1V

USE 10 DIVIDER PROBE

0.1V/div., 0.1 μ s/div.

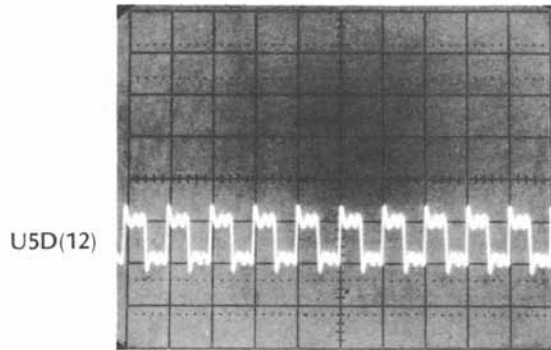

U5D(12)

1

0.1V/div., 20 μ s/div.

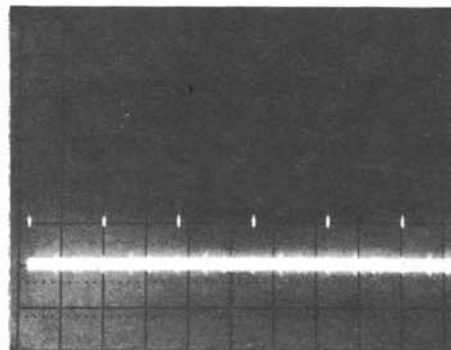

U4A(7)

2

0.1V/div., 20 μ s/div.

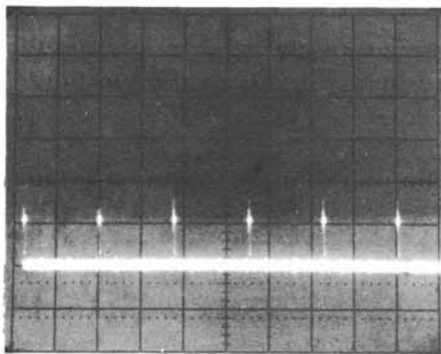

U5D(13)

3

0.1V/div., 01. ms/div.

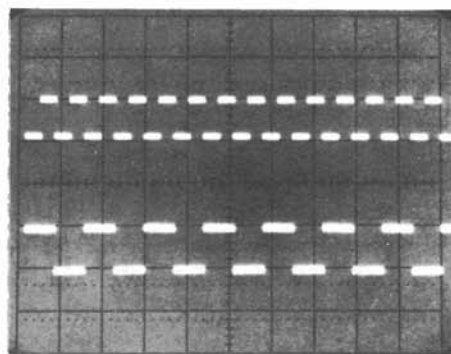

U3A(2)

U4B(15)

4

0.1V/div., 0.1 ms/div.

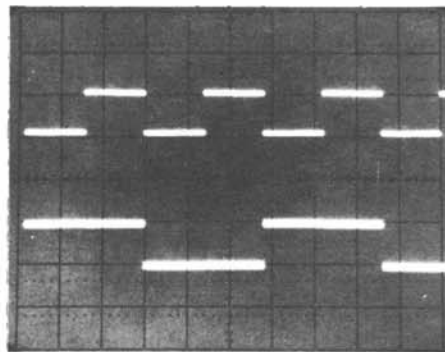

U2B(15)

U2A(2)

5

First part of page 8-75, which folds out.

Before troub
and A16 Arr

Connect BN
START inpu
50Ω, X1, Di
HOLD and F
on. Counter

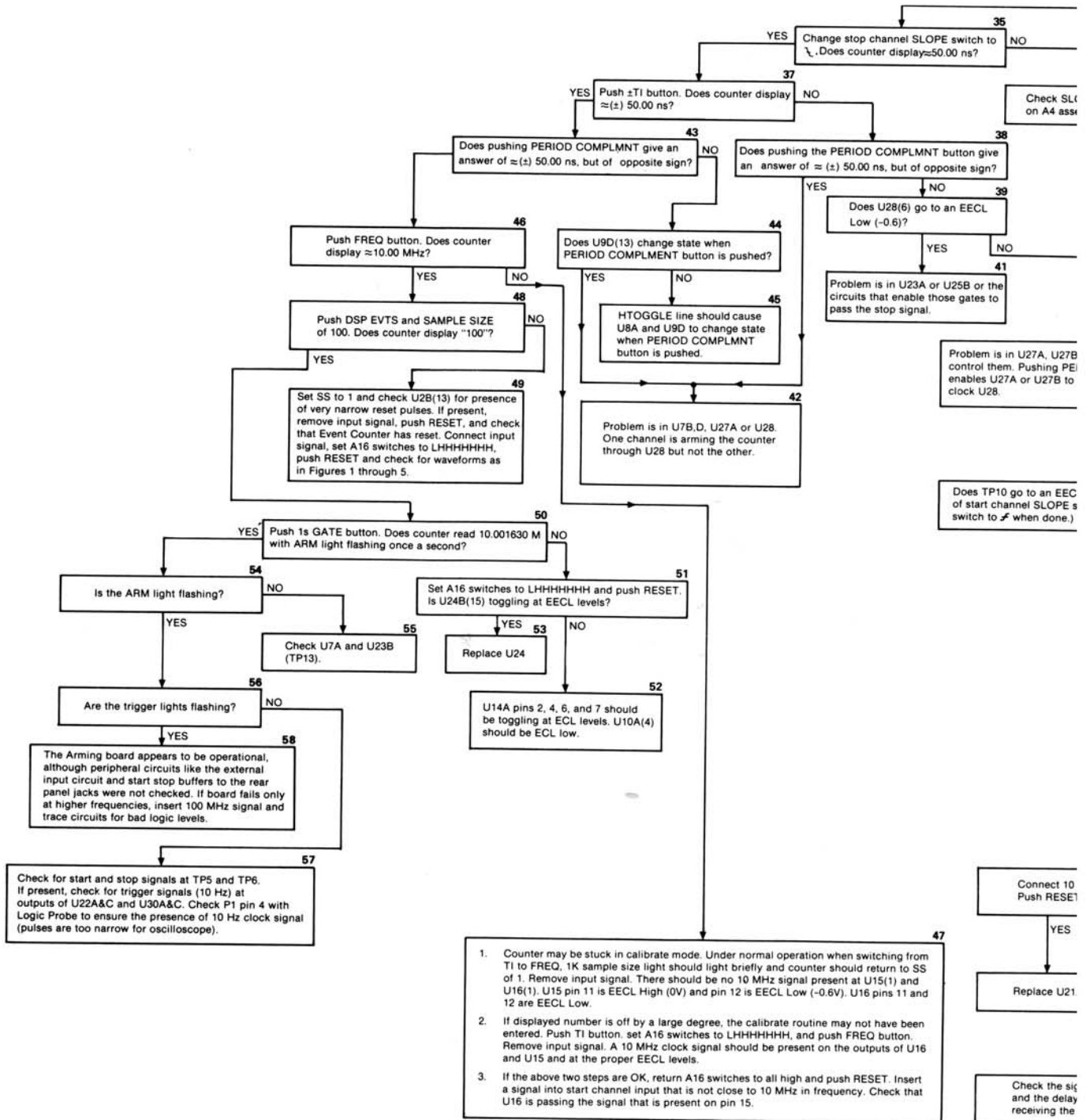

Second part of page 8-75, which folds out.

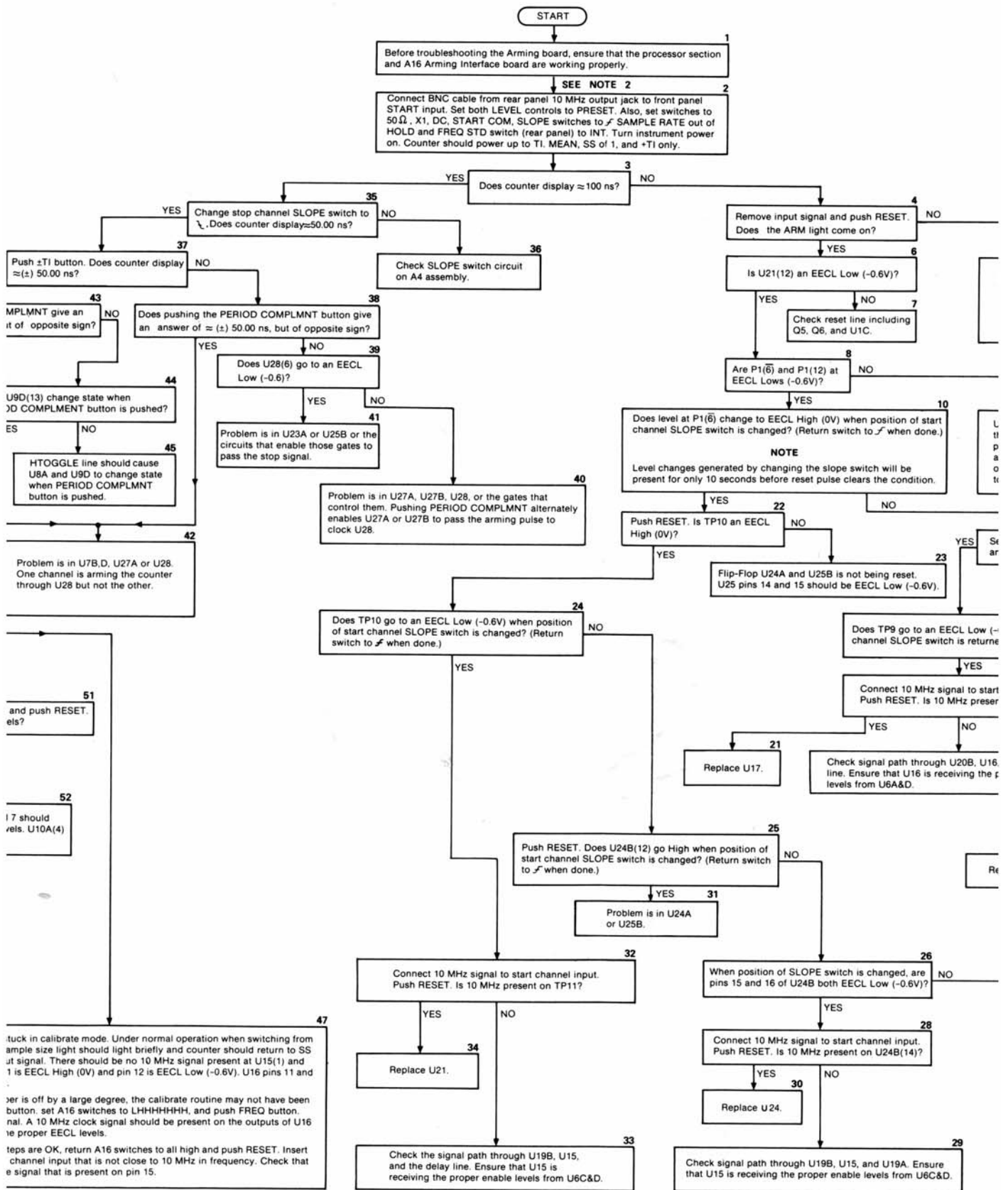

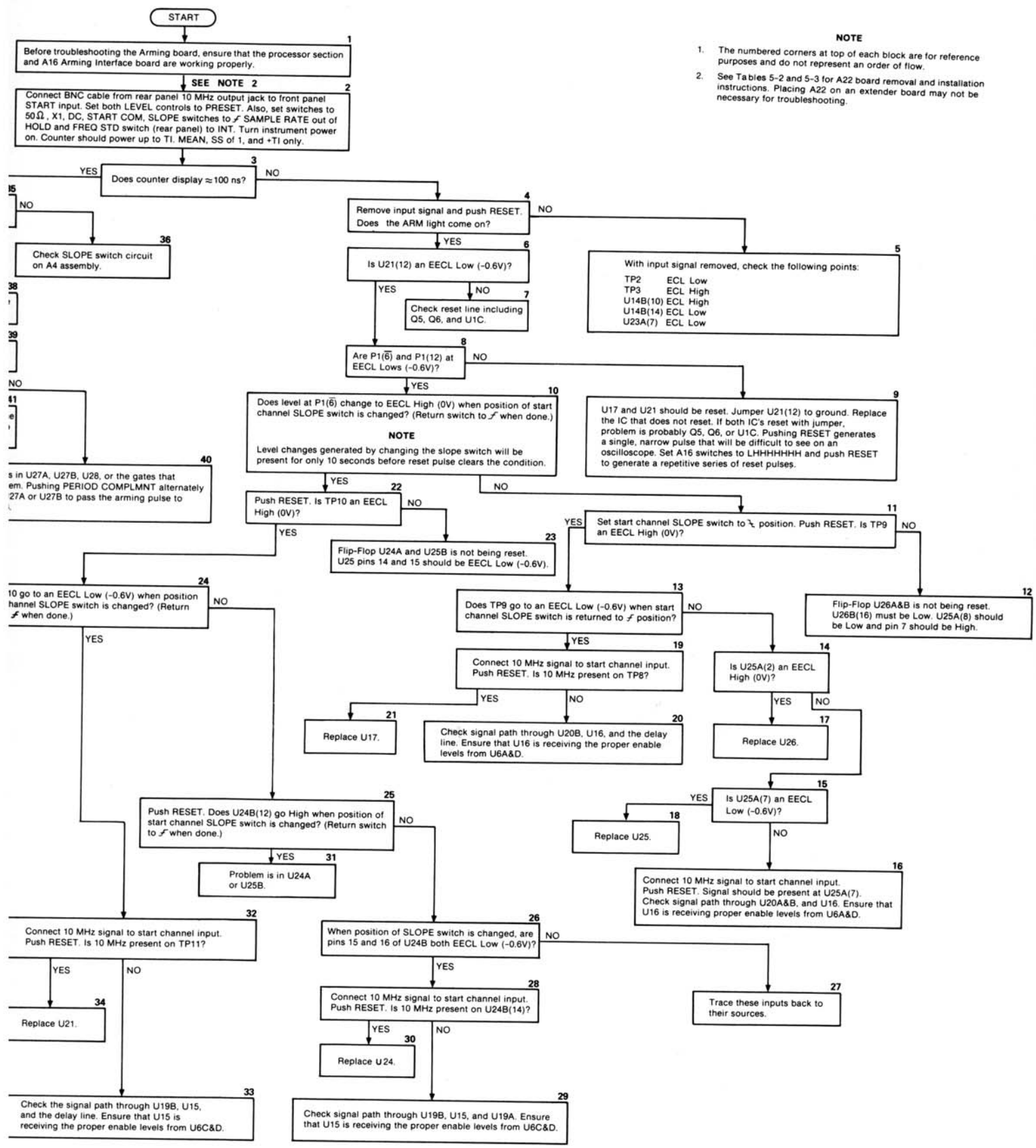

Figure 8-18. A18 Assembly Troubleshooting Flowchart

Fourth (and final) part of page 8-75, which folds out.

8-279. A23 FRONT PANEL TROUBLESHOOTING

8-280. Digit LED Displays

8-281. There is no circuitry on the front panel board, other than the LEDs themselves, that affect the operation of the display. The control circuitry is found on the A11 Display Interface board.

8-282. To replace a bad display LED, start by sliding the three tabs on the display window to the left. Pull the top of the window forward and lift the window clear. Remove the faulty LED with a pair of IC tongs. The displays are in sockets and are not soldered in.

8-283. Pushbutton Switch LEDs

8-284. As with the digit display LEDs, there is no circuitry on the front panel board that affects the LEDs of the pushbutton switches. The control circuitry is found on the A11 Display Interface board.

8-285. To test for a bad lamp, push the front panel RESET button. All front panel pushbutton lights should now be on. If only one pushbutton LED is out, the LED is bad and should be changed. However, if an entire column (vertical) or row (horizontal) of LEDs is out, the problem is on the A11 Display Interface board.

8-286. Pushbutton Switches

8-287. To check for proper contact closure of the front panel switches, place the A11 Display Interface board on an extender board and check for proper signatures at A11U15 pin 6.

SETUP:

A16 Arming Interface switches to normal position (all up). A9 Processor switches to normal position (HHHHLLLHLX) or to freerun position (LLLLHHHLX). Connect 5006A Signature Analyzer Clock to A9 CLK test point and Start, Stop to A11U17(8). Set the 5006A START, STOP, and CLOCK polarities to $\bar{}$. Turn 5370B instrument power on.

8-288. Check for signatures at A11U15 pin 6 for each key. If no key is depressed, pin 6 should be Low. If a signature is present, it indicates a key is stuck closed. Compare the signature to those listed to determine in which column the faulty key is located.

5006A Probe at A11U15(6)

Column #1

T.I.
FREQ }
1 PERIOD } 6U86
0.1 s }

Column #2

TRIG LVL }
PERIOD } H290
0.01s }
1 s }

Column #3

MEAN }
MIN } U138
DSP REF }
DSP EVTS }

Column #4

STD DEV }
MAX } C4CF
CLR REF }
SET REF }

Column #5

1 }
1K } 69CP
100K }
MAN RATE }

Column #6

100 }
10K } 7FUP

Column #7

+T.I. ONLY }
EXT HOLDOFF } 7774

Column #8

±T.I. }
PERIOD COMPLMNT } 8636
EXT ARM }

Other Keys

TP
A11U15(6)
A11J3(10)
A11J2(9)

Key
RESET
LOCAL/REMOTE
MAN INPUT

SIG/Logic State
7774
Low with Key in
Low with Key in

8-289. Annunciator LEDs

8-290. If when pushing front panel reset, one of the following annunciators do not light, replace that LED: *, K, evt, M, m, Hz, μ, n, s, OF, p, V, LDTN, TALK.

8-291. The remaining LEDs are driven by circuitry on the A23 Front Panel board. During a power up reset, the Start and Stop LEDs will not light. Once power-up reset has finished, the ARM light should be on. Push the ±T.I. button to cause the Start or Stop light to appear. Then push PERIOD COMPLMNT for Stop or Start.

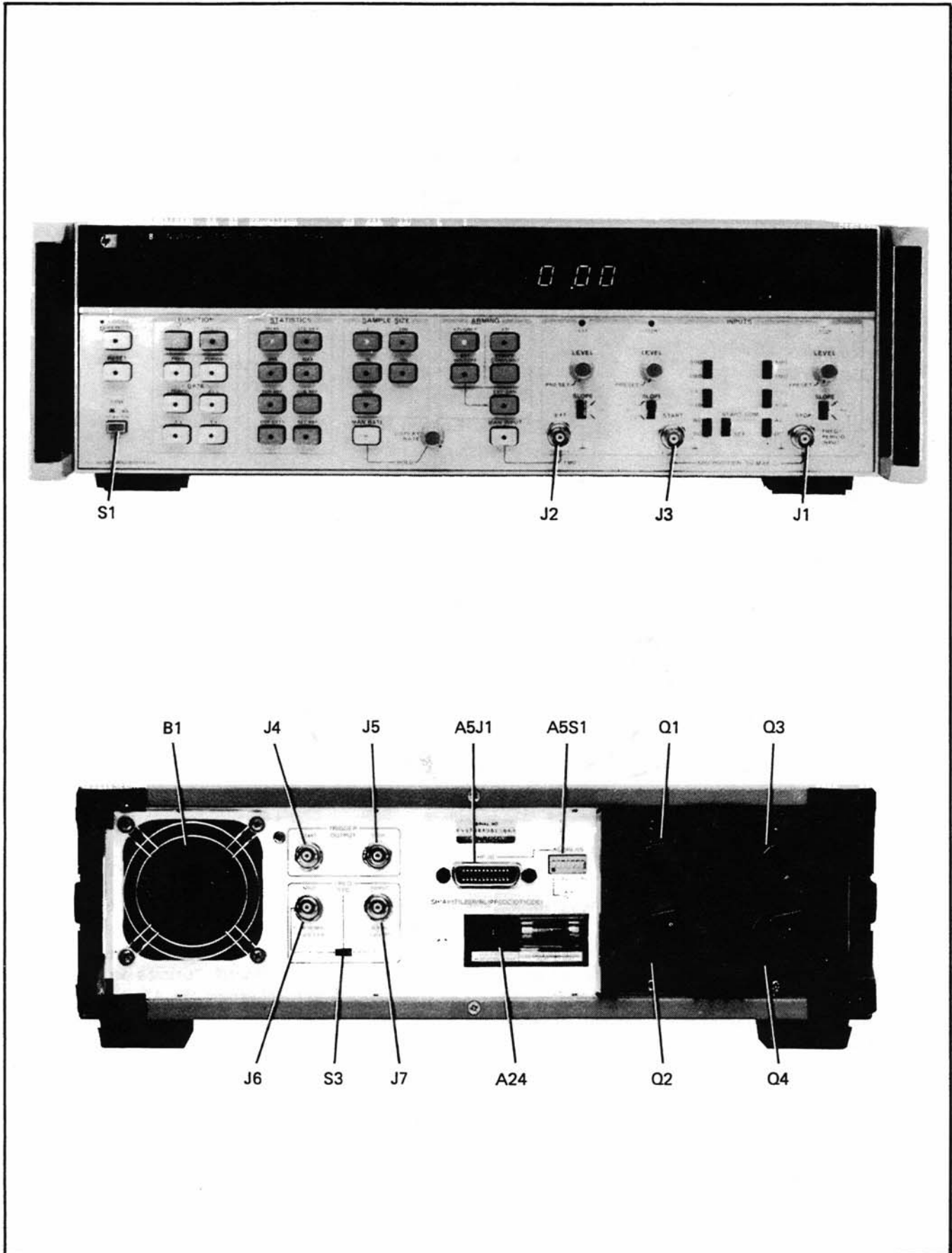

Figure 8-19. Front and Rear Panel Designations

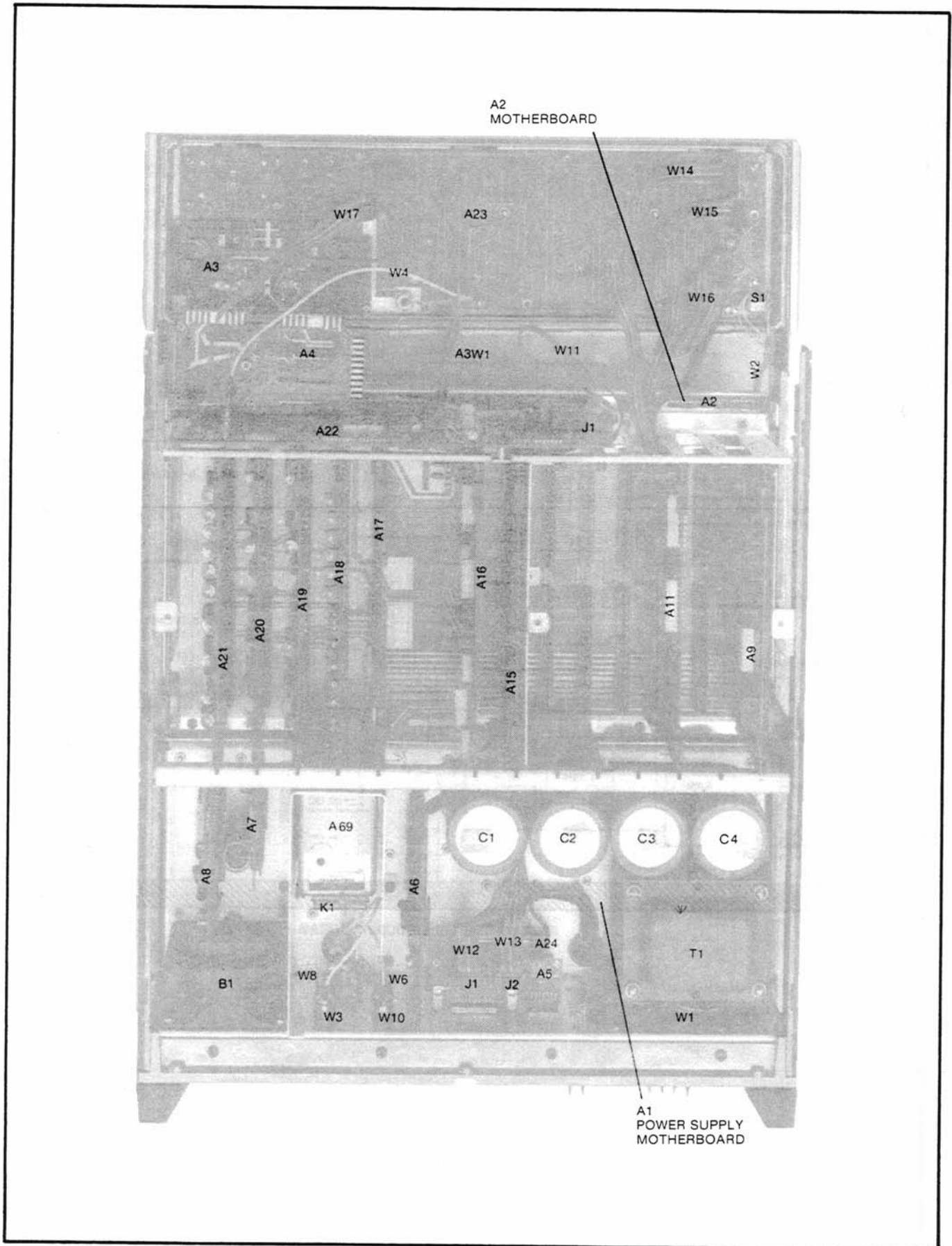
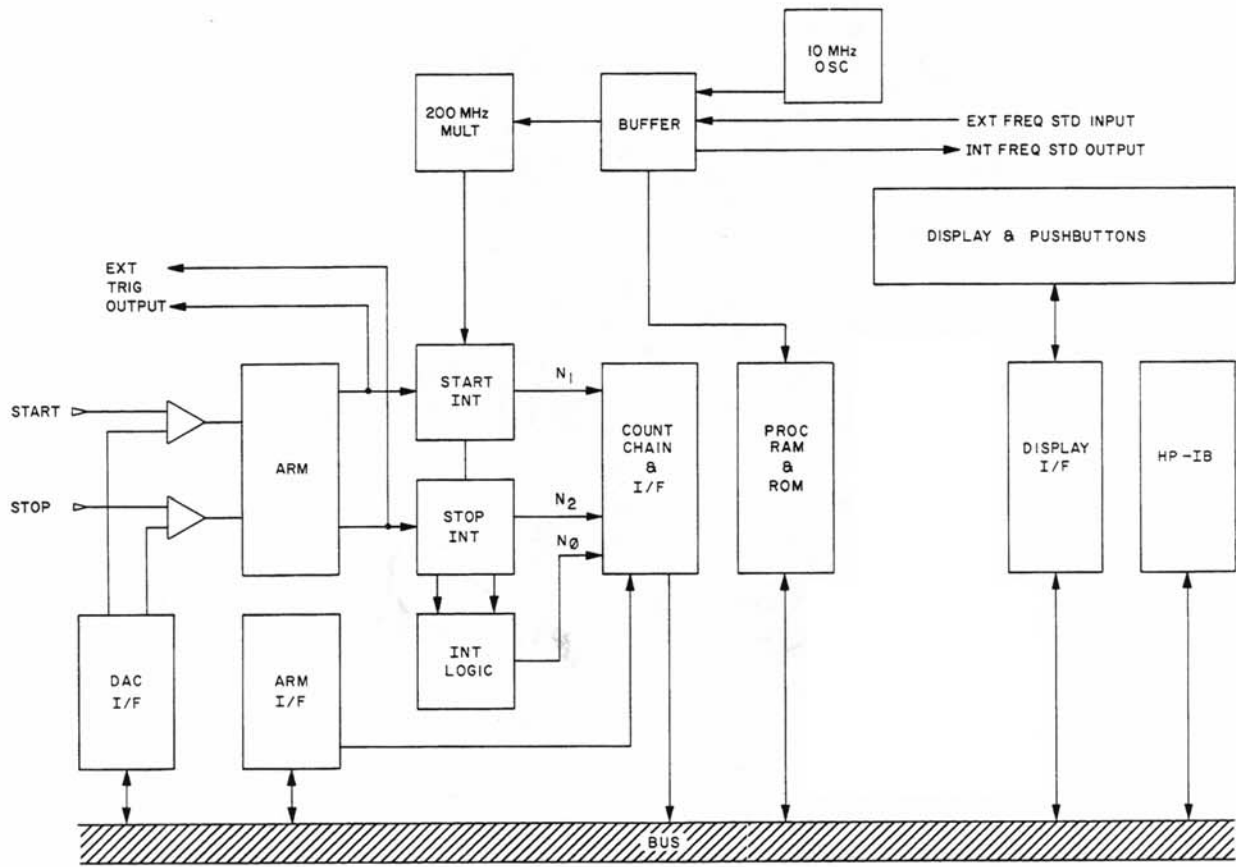

Figure 8-20. Top Internal View



5370B SIMPLIFIED BLOCK DIAGRAM

Part of Figure 8-21. Simplified/Overall Block Diagram

A6 POWER SUPPLY CONTROL ASSEMBLY

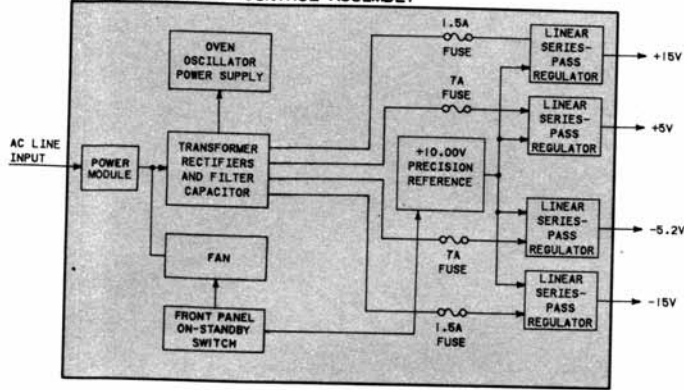

A69 10MHZ OSCILLATOR

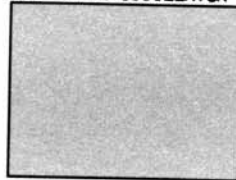

A8 FREQUENCY BUFFER

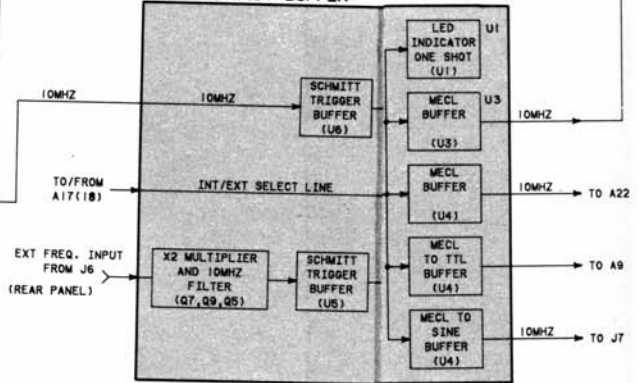

A3 INPUT AMPLIFIER ASSEMBLY

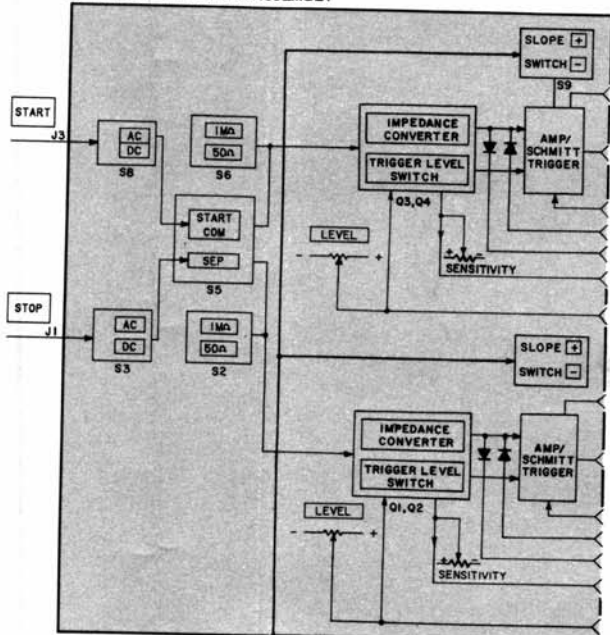

A4 INTERCONNECT BOARD ASSEMBLY

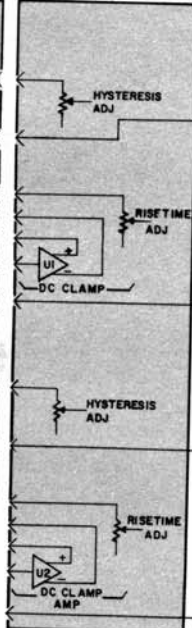

A22 ARMING ASSEMBLY

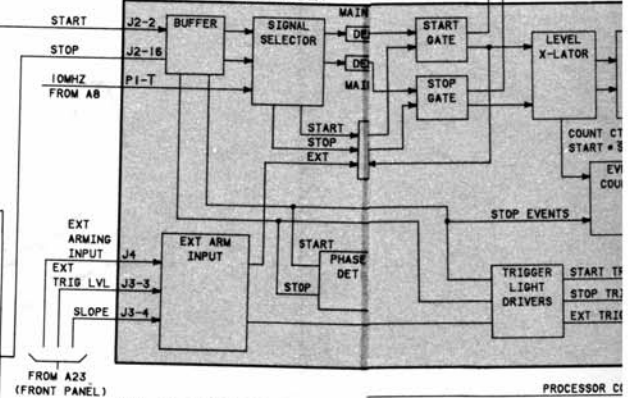

A16 ARMING INTERFACE

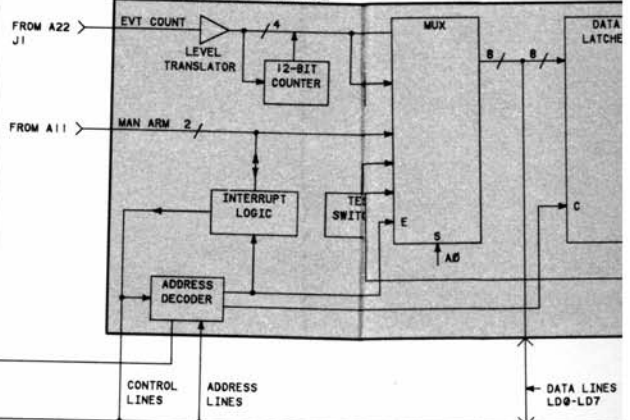

P/O A18 DAC NO LOGIC

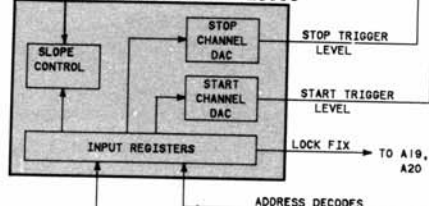

First part of page 8-81, which folds out.

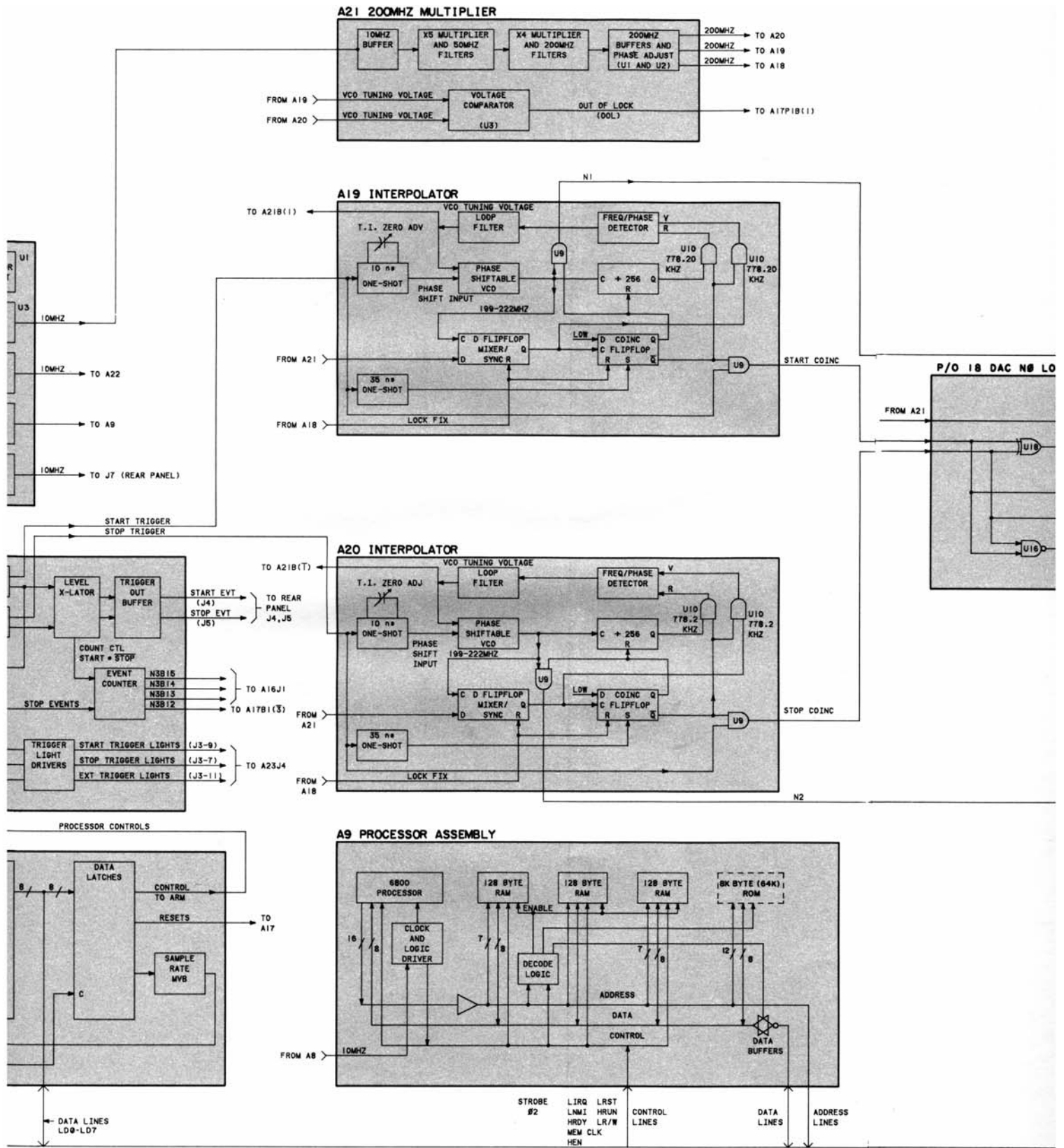

Second part of page 8-81, which folds out.

TO A20
 TO A19
 TO A18

 TO A17P1B(1)

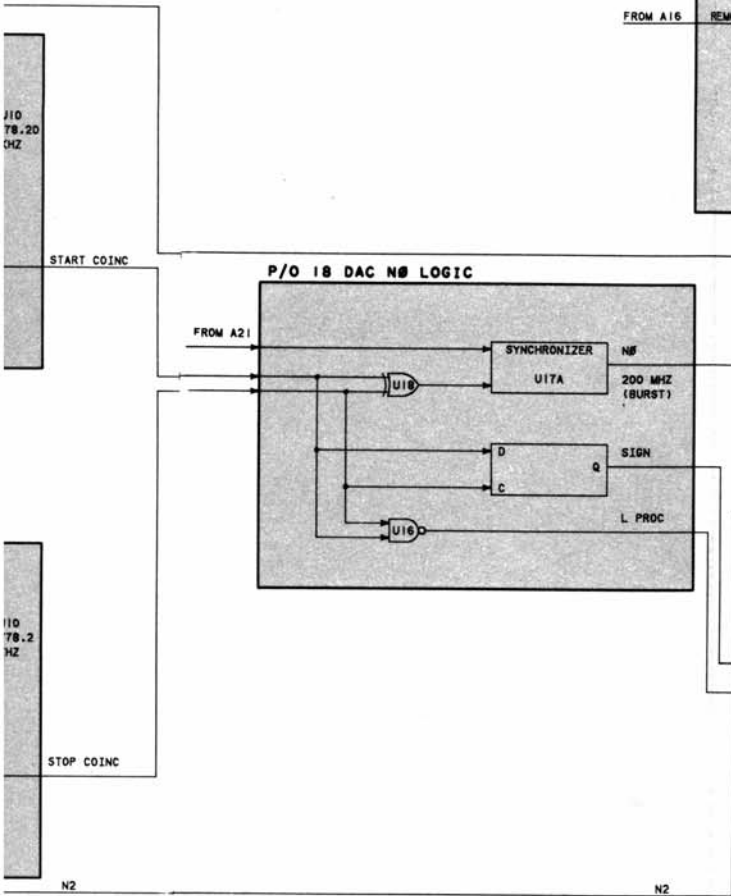

A11 DISPLAY INTERFACE

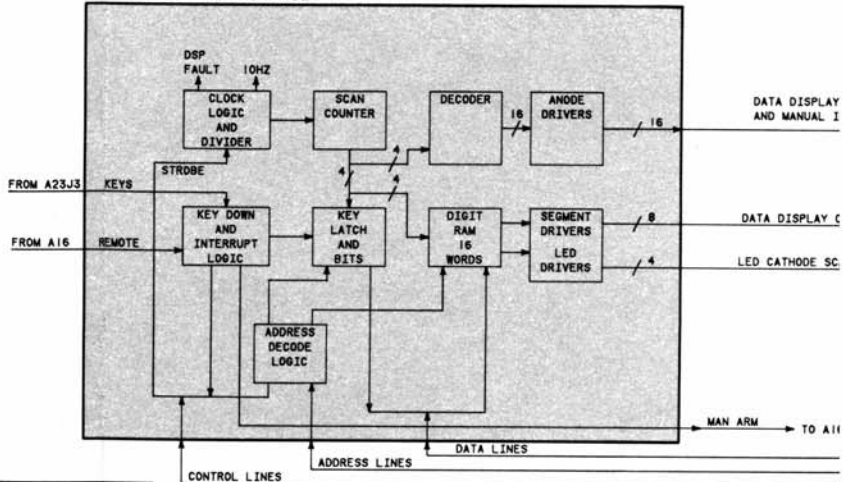

A17 COUNT CHAIN

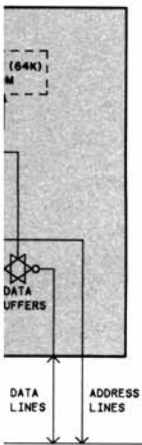
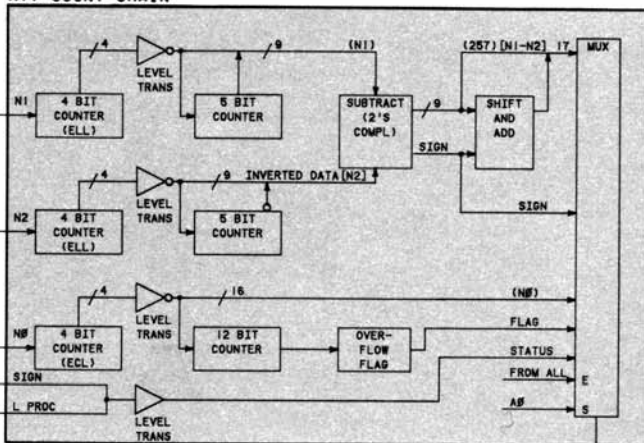

MICROPROCESSOR BUS

Third part of page 8-81, which folds out.

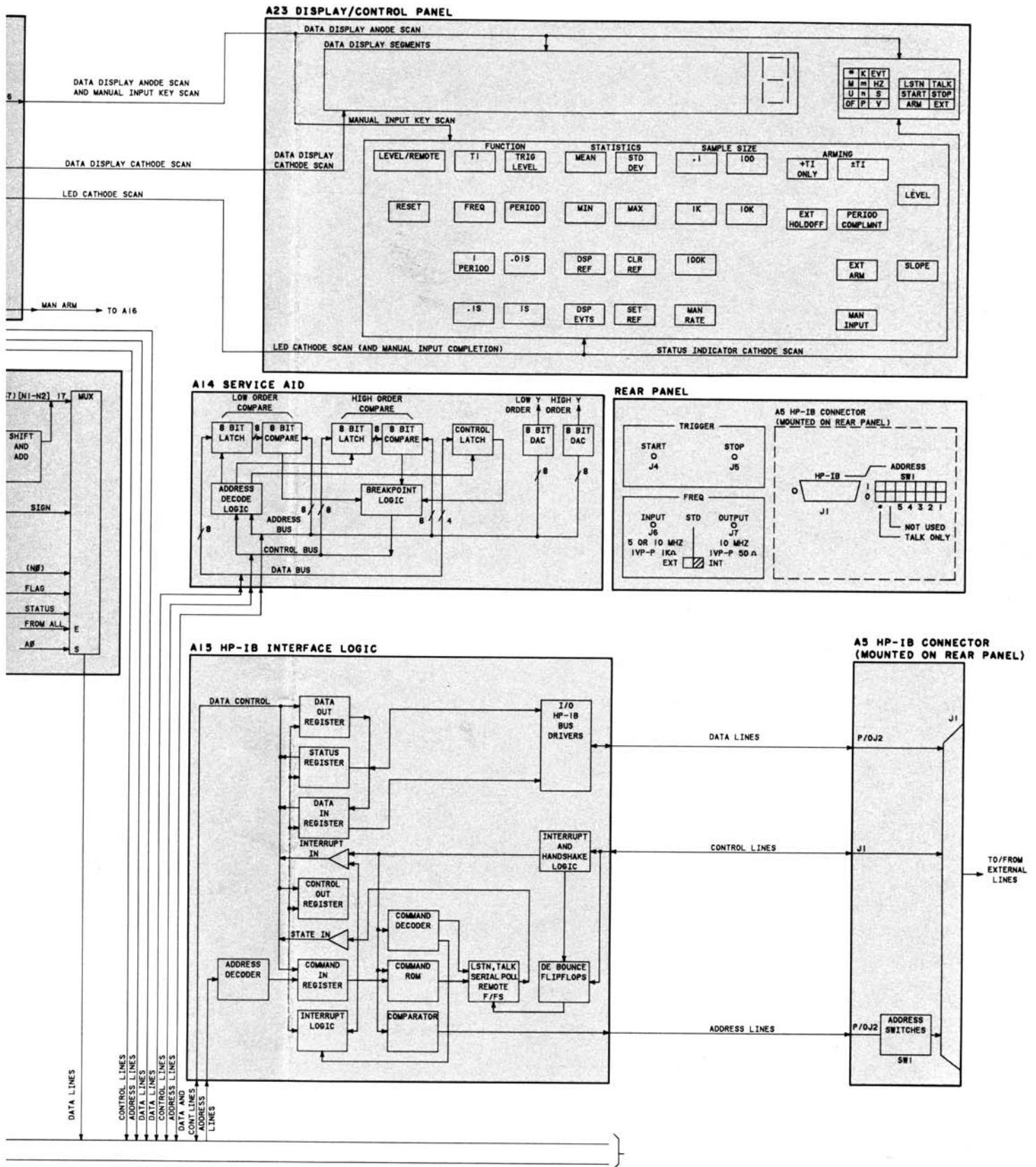
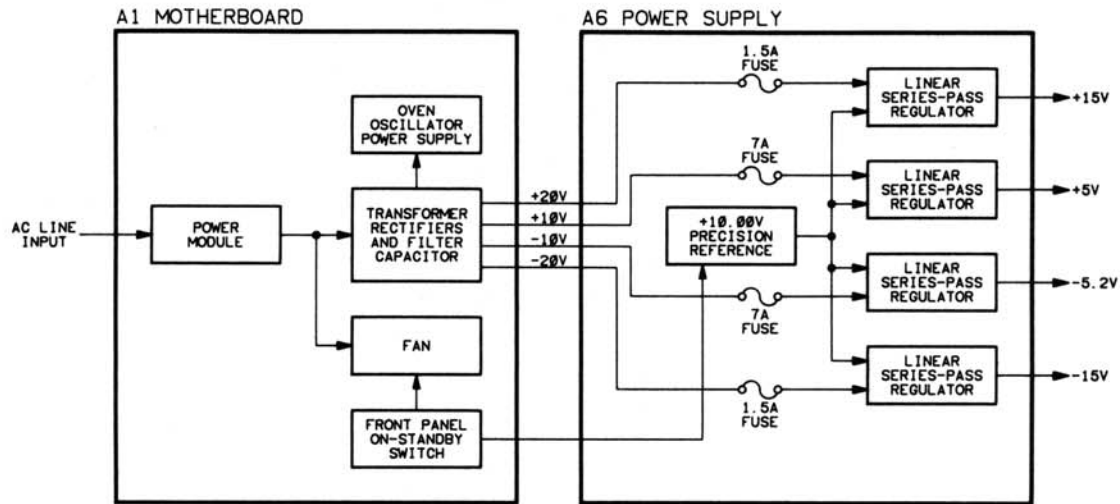

Figure 8-21. Simplified/Overall Block Diagram



A1 POWER SUPPLY MOTHERBOARD ASSEMBLY A6 POWER SUPPLY CONTROL ASSEMBLY

The Power Supply Motherboard/Power Supply Control Assemblies (A1, A6) supply all dc power for the instrument, except for the Quartz Crystal Oven Oscillator. The ac line voltage enters through the Power Module (correct selection of line input voltage determined by Power Module card) to the Power Transformer primary windings and to the instrument fan. The ac voltages from the secondaries of the power transformer are rectified and filtered and sent to the voltage regulation circuitry on A6. A separate transformer secondary supplies power to the Oven Oscillator Power Supply (A7).

When the front panel STBY-ON switch is activated, ac power is sent to the fan, and dc voltage is supplied to the precision voltage reference IC. The reference IC output of +10.0V is then applied to the four linear, series-pass regulators which convert the unregulated dc voltages of +10V, +20V, -20V, and -10V (fused at the input of A6) to +5V, +15V, -15V, and -5.2V for distribution throughout the instrument. The four voltage regulators are referenced to a single +10.0V precision reference IC (A6U5).

Part of Figure 8-22. A1 Power Supply Motherboard, A6 Power Supply Control Assemblies

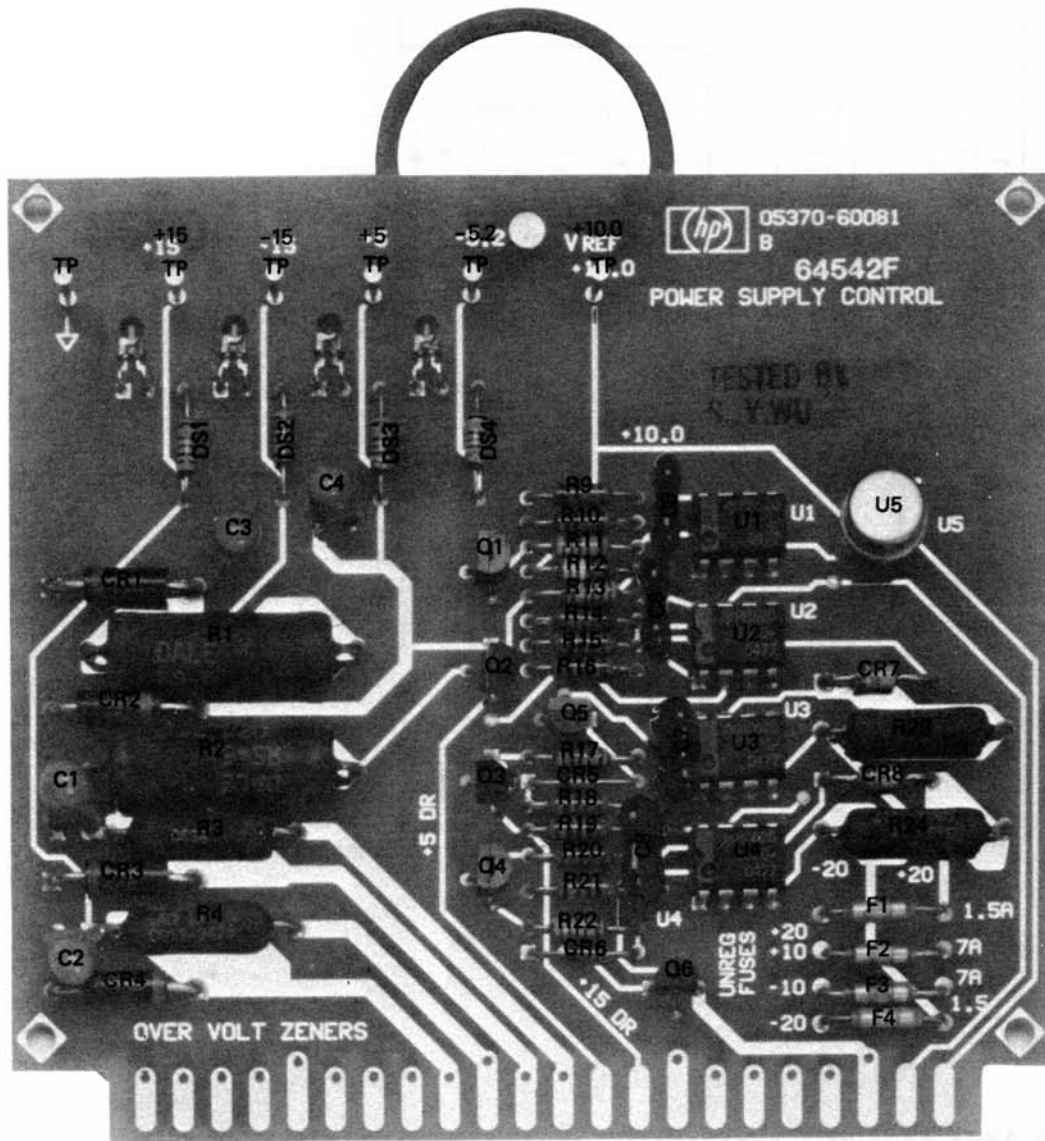

A6

First part of page 8-83, which folds out.

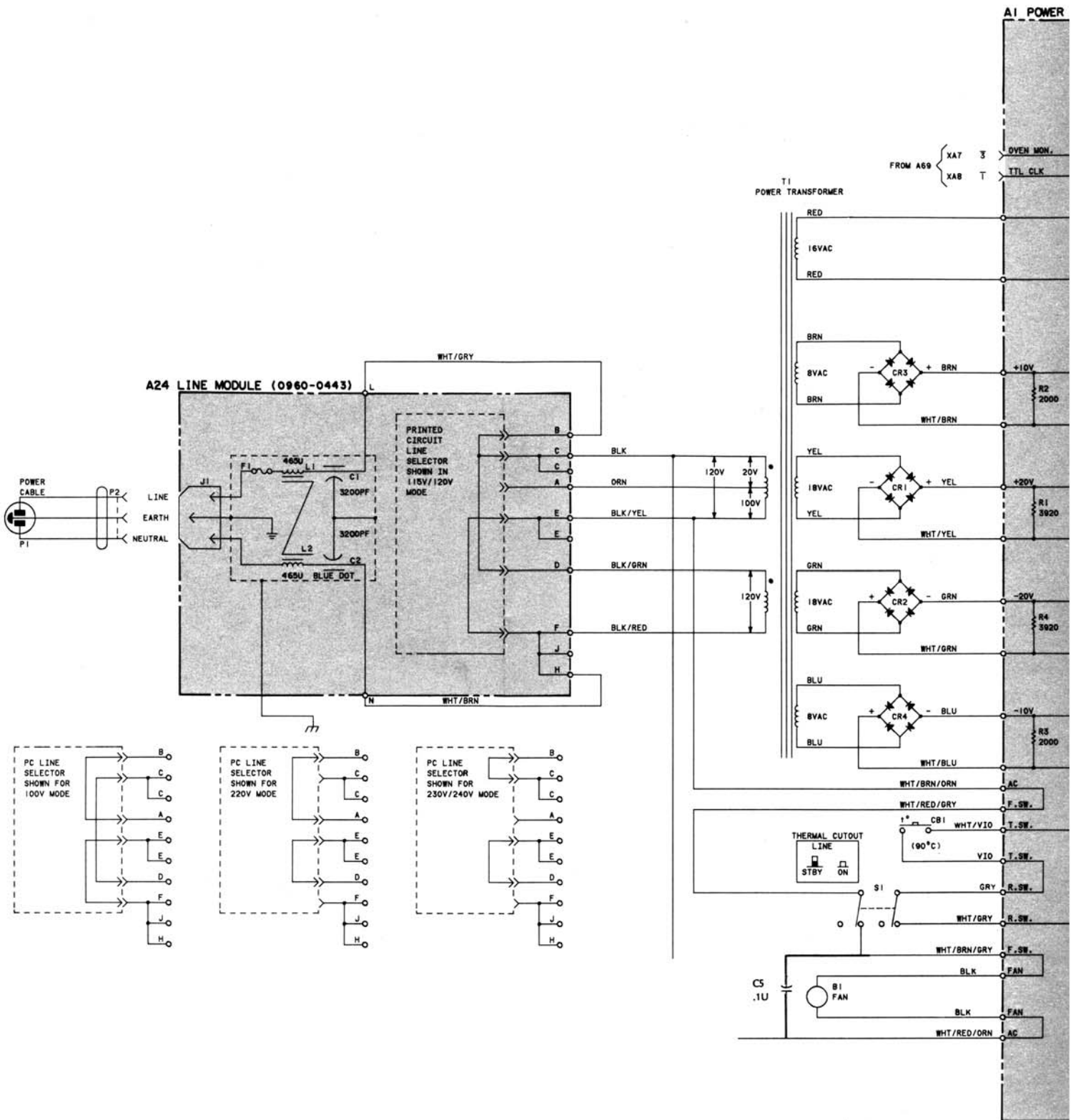

Second part of page 8-83, which folds out.

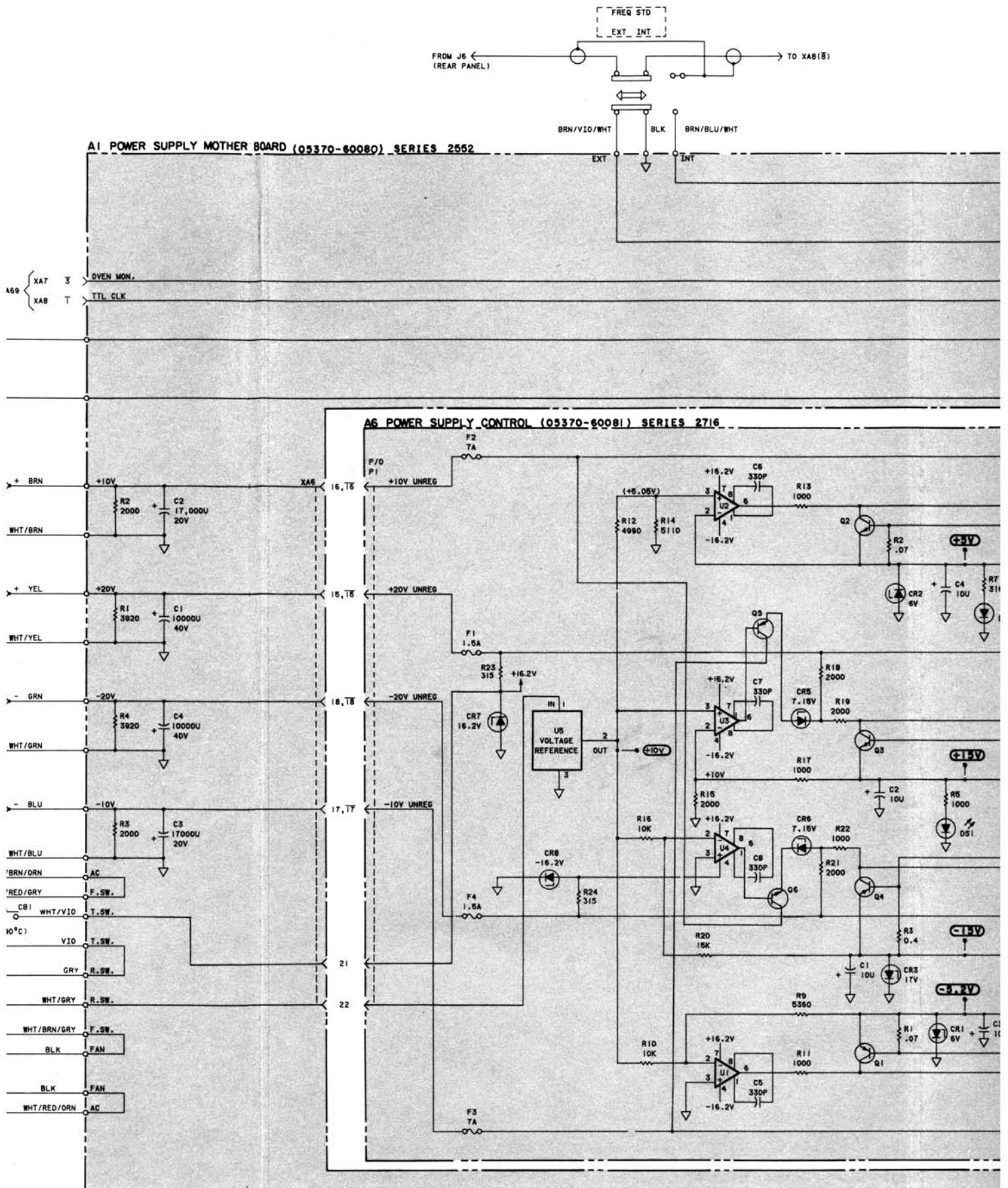

Third part of page 8-83, which folds out.

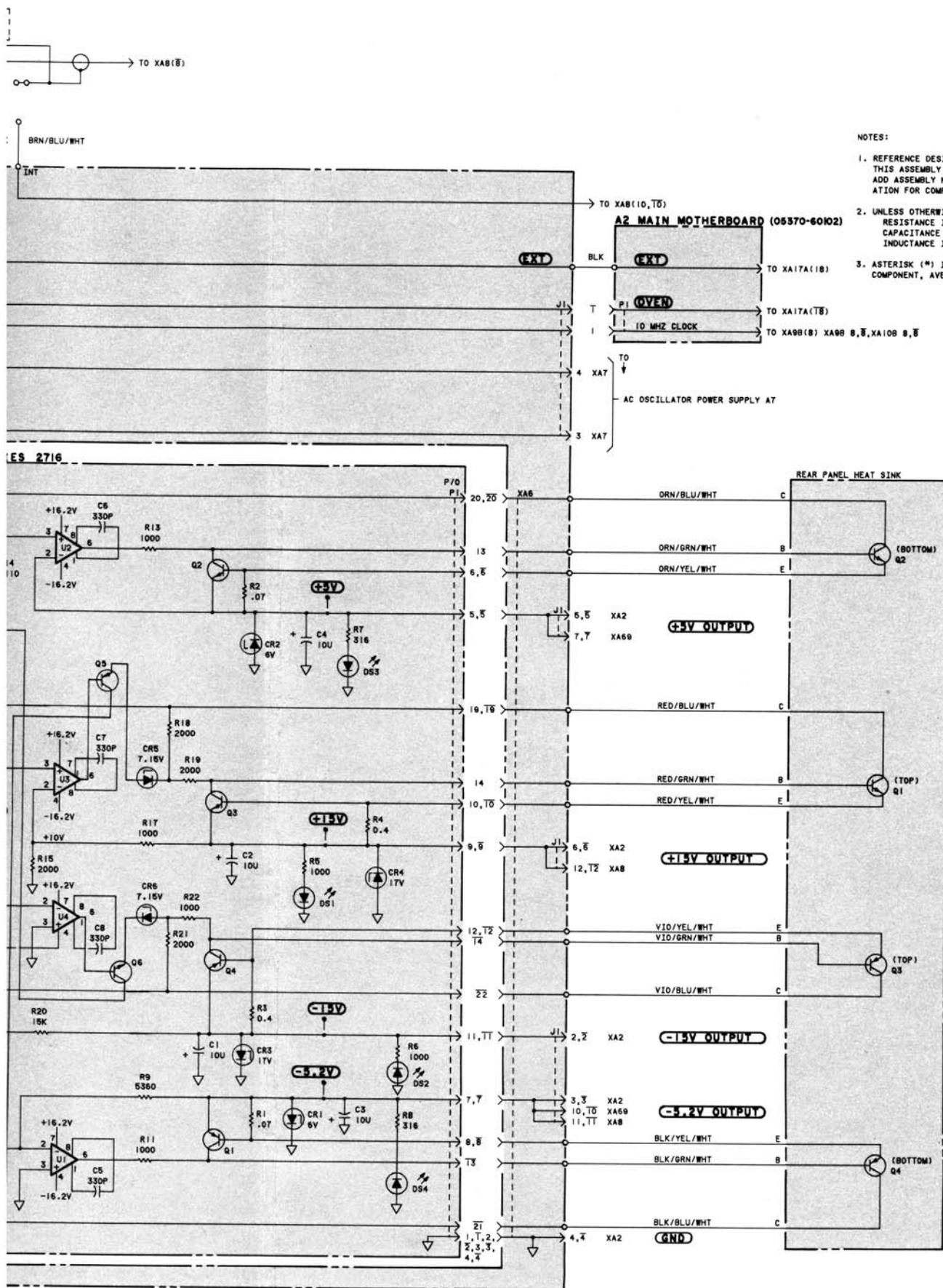

- NOTES:
1. REFERENCE DESIGNATIONS WITHIN THIS ASSEMBLY ARE ABBREVIATED. ADD ASSEMBLY NUMBER TO ABBREVIATION FOR COMPLETE DESCRIPTION.
 2. UNLESS OTHERWISE INDICATED: RESISTANCE IN OHMS, CAPACITANCE IN FARADS, INDUCTANCE IN HENRIES.
 3. ASTERISK (*) INDICATES SELECTED COMPONENT, AVERAGE VALUES SHOWN

Figure 8-22. A1 Power Supply/Motherboard Assembly,
A6 Power Supply Control Assembly
A24 Line Module Assembly

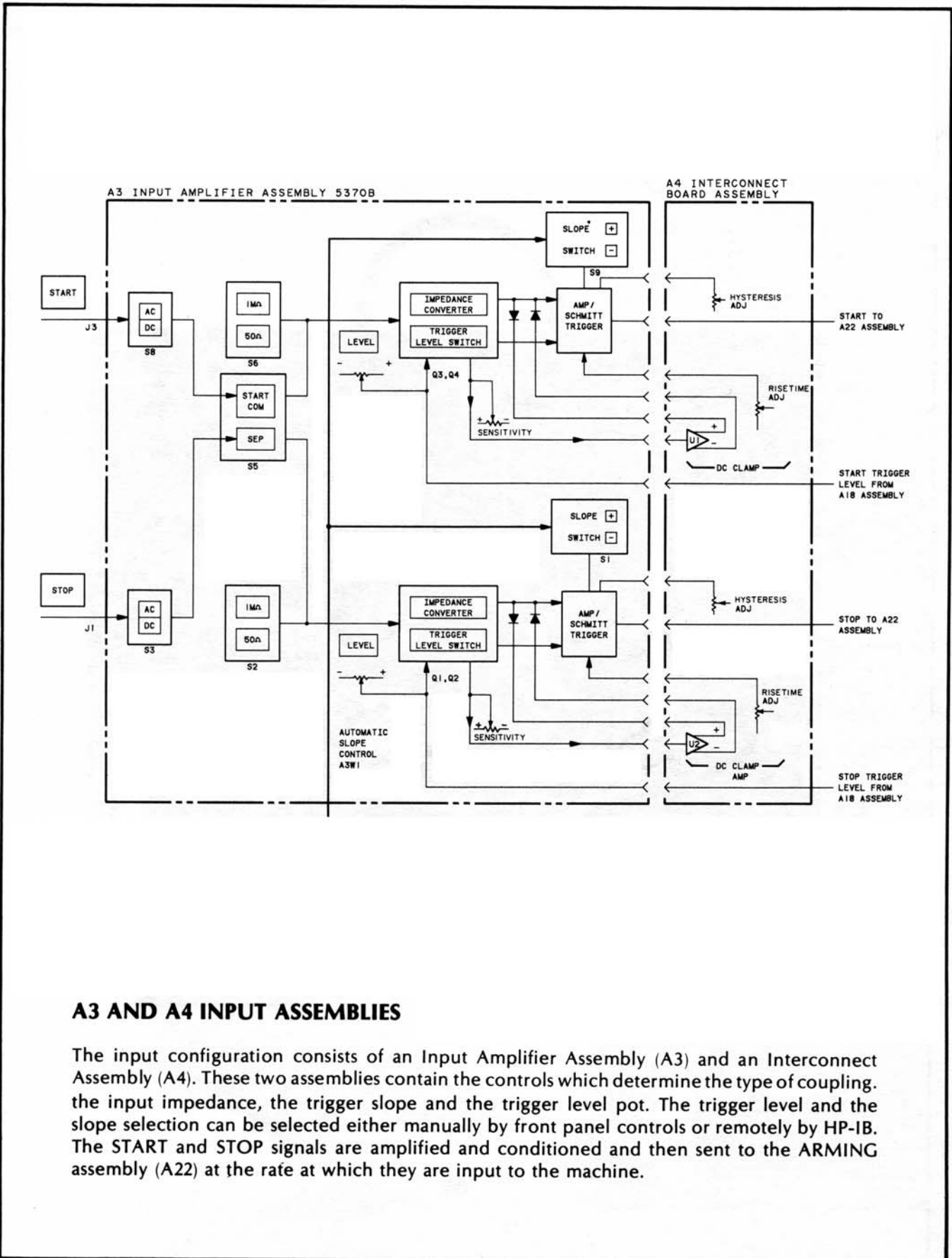

A3 AND A4 INPUT ASSEMBLIES

The input configuration consists of an Input Amplifier Assembly (A3) and an Interconnect Assembly (A4). These two assemblies contain the controls which determine the type of coupling, the input impedance, the trigger slope and the trigger level pot. The trigger level and the slope selection can be selected either manually by front panel controls or remotely by HP-IB. The START and STOP signals are amplified and conditioned and then sent to the ARMING assembly (A22) at the rate at which they are input to the machine.

Part of Figure 8-23. A3 and A4 Input Assemblies

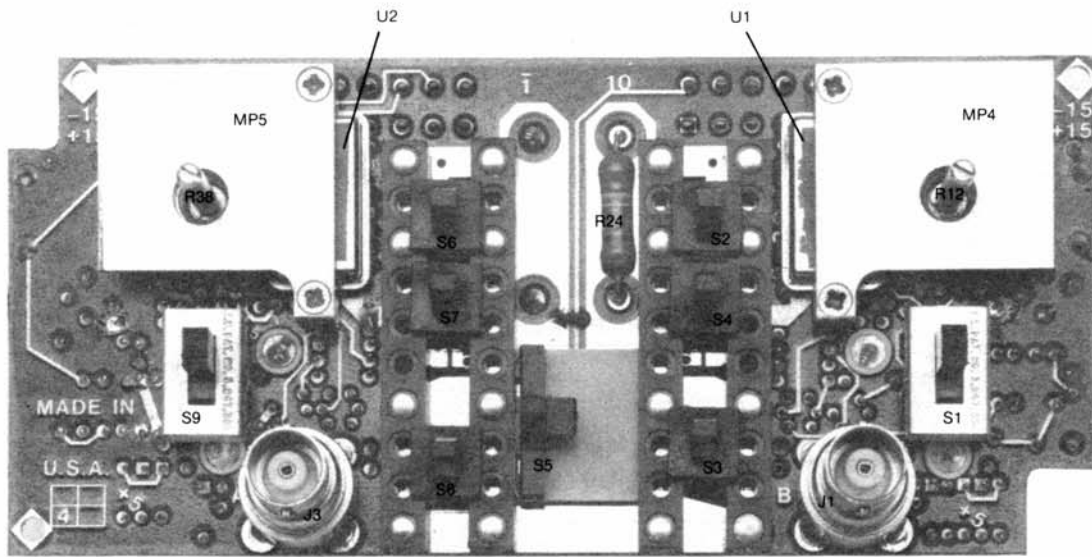

START

STOP

FRONT VIEW

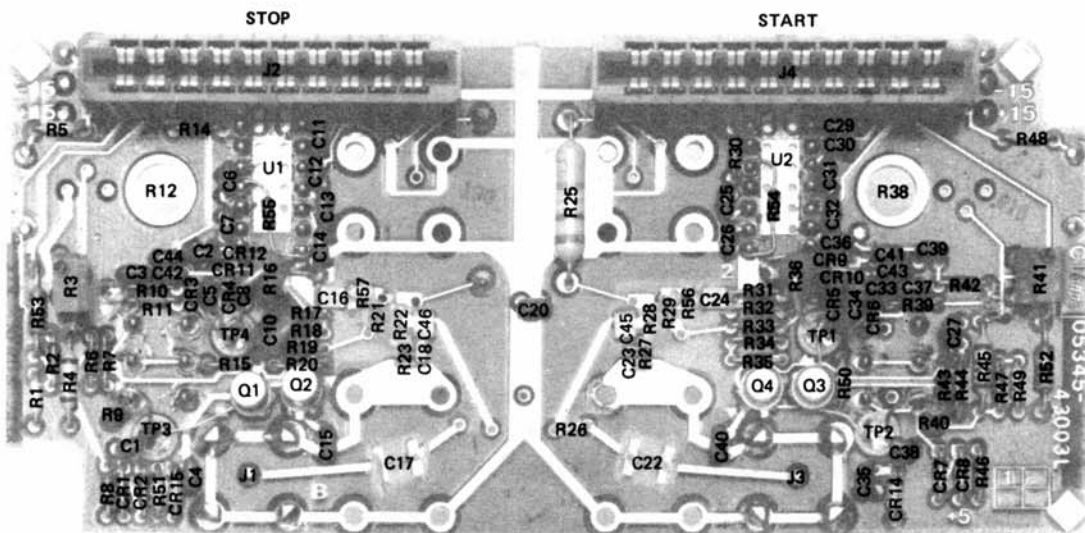

REAR VIEW

A3

Part of Figure 8-23. A3 and A4 Input Assemblies
 First part of page 8-85, which folds out.

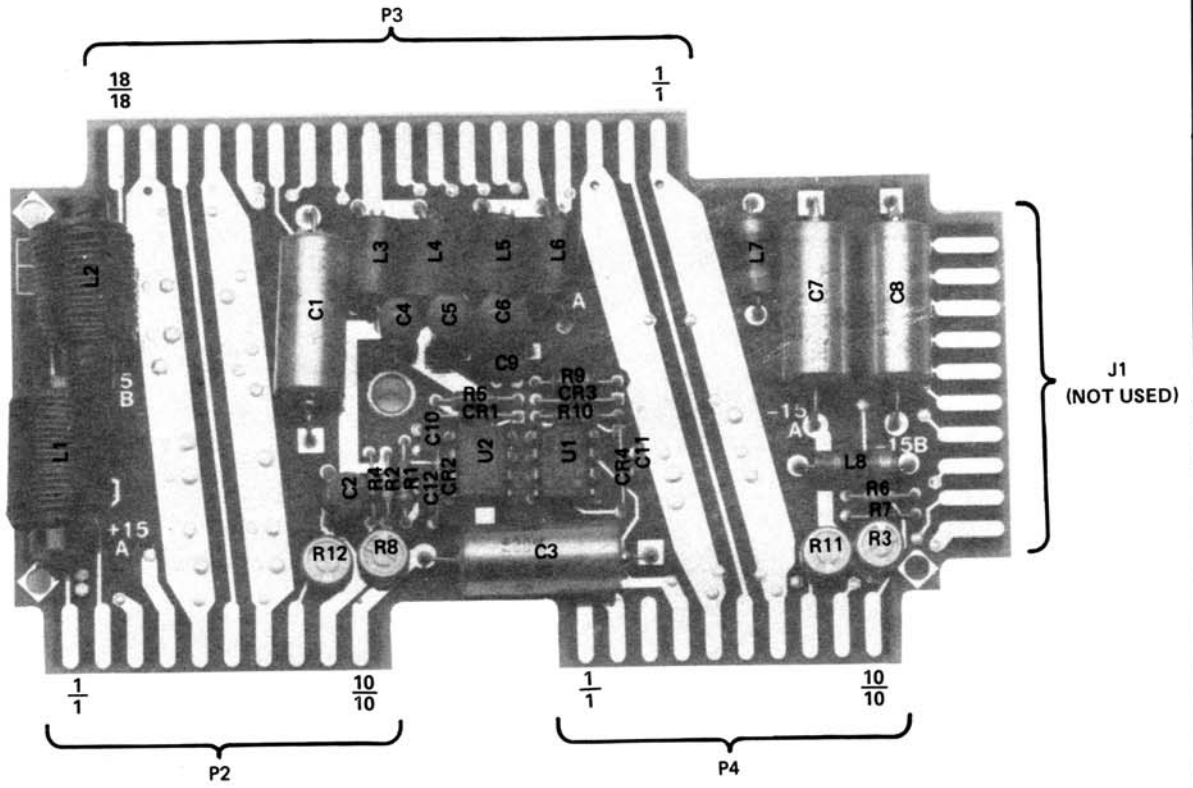

A4

Second part of page 8-85, which folds out.

A3 INPUT AMPLIFIER ASSEMBLY (05345-60138) (SERIES 2438)

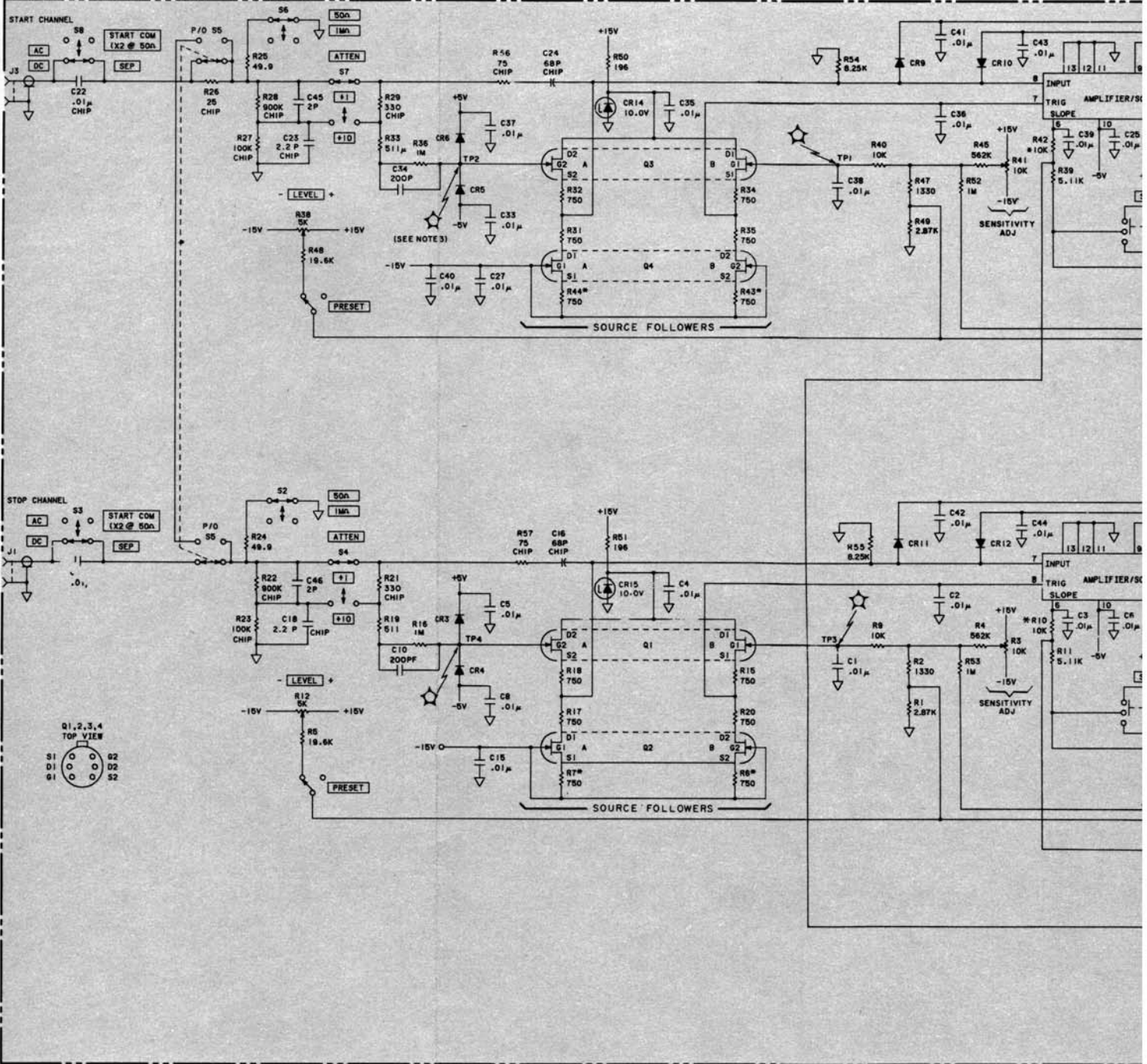

Part three of page 8-85, which folds out.

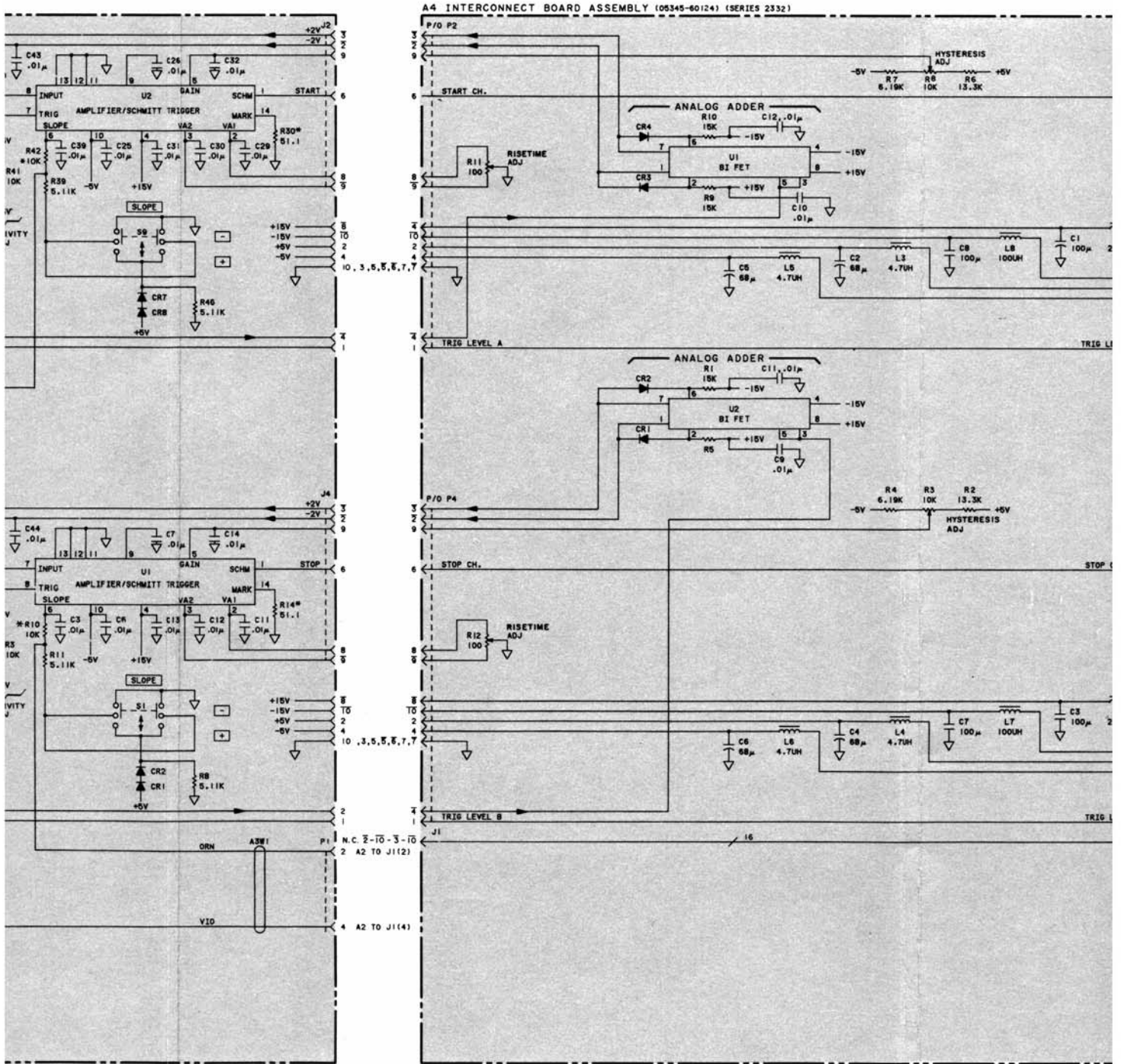

Part four of page 8-85, which folds out.

ASSEMBLY (00345-60124) (SERIES 2332)

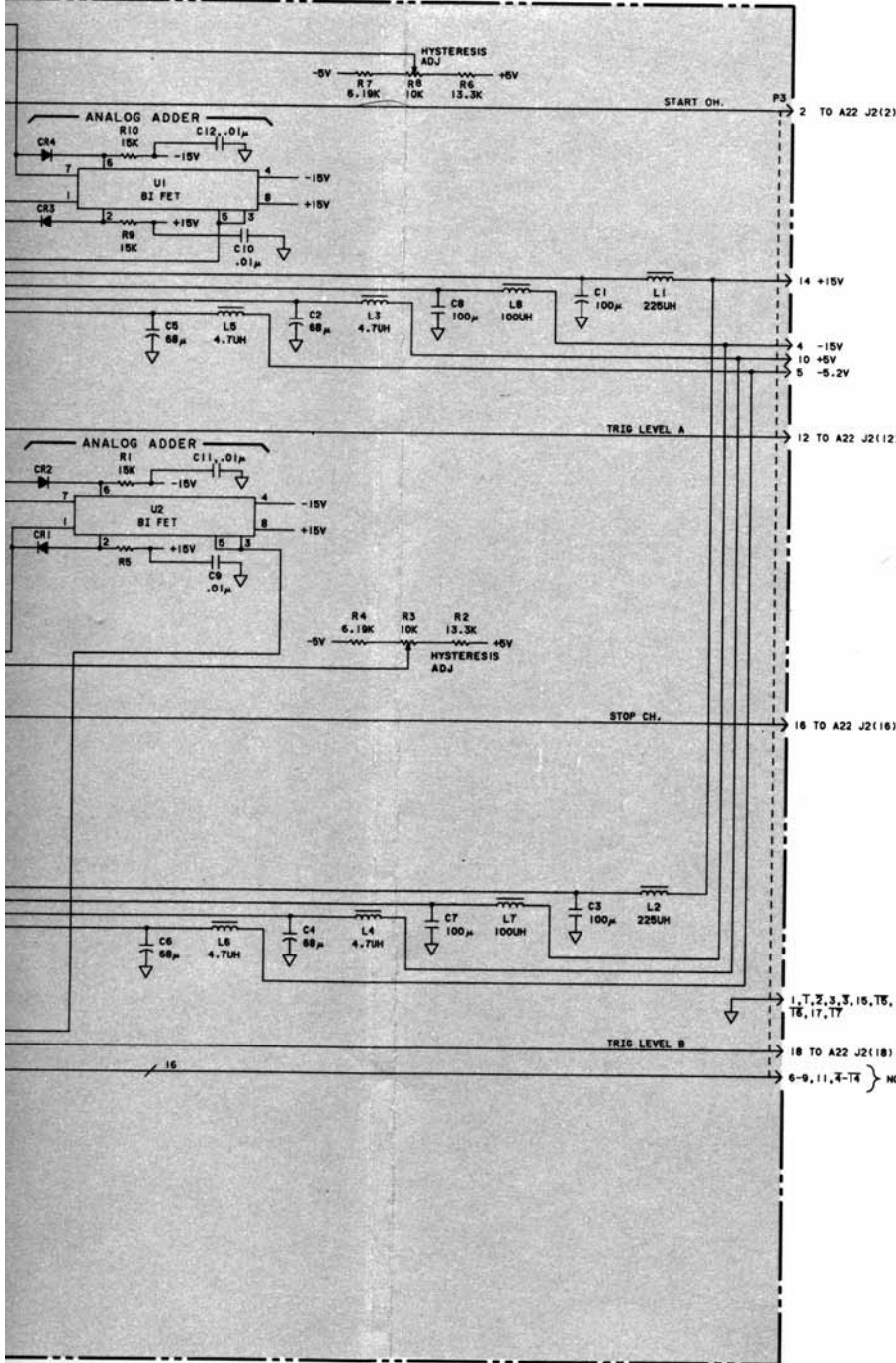

- NOTES:
1. REFERENCE DESIGNATIONS WITHIN THIS ASSEMBLY ARE ABBREVIATED. ADD ASSEMBLY NUMBER TO ABBREVIATION FOR COMPLETE DESCRIPTION.
 2. UNLESS OTHERWISE INDICATED: RESISTANCE IN OHMS; CAPACITANCE IN FARADS; INDUCTANCE IN HENRIES
 3. * THESE ARE SPECIAL TEST POINTS FOR TROUBLESHOOTING ONLY. THESE ARE NOT STAND-OFF TERMINALS.

Figure 8-23. A3 Input Amplifier Assembly, A4 Interconnect Board Assembly

Part five (the last part) of page 8-85, which folds out.

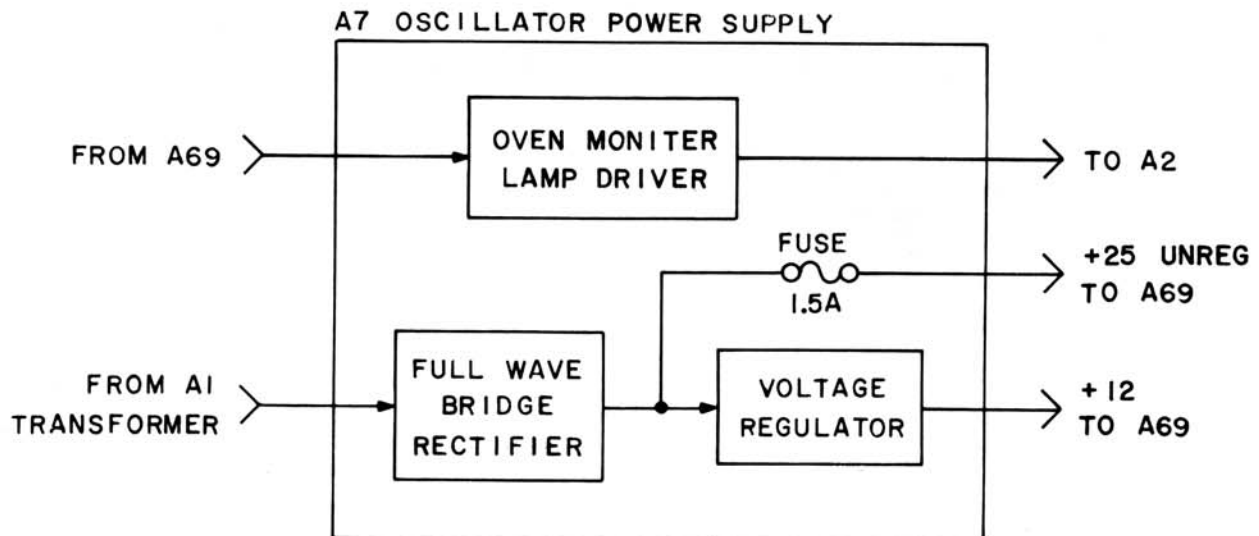

A7 OSCILLATOR POWER SUPPLY ASSEMBLY

The A7 Assembly provides the voltage needed by the Quartz Crystal Oven Oscillator (10811A). The 16V ac from power transformer T1 is rectified, filtered and regulated by the assembly. There is also an oven monitor circuit which lights an indicator in the front panel display whenever the crystal oven is below operating temperature as is the case when the instrument is first connected to the ac power.

Part of Figure 8-24. A7 Oven Oscillator Power Supply Assembly

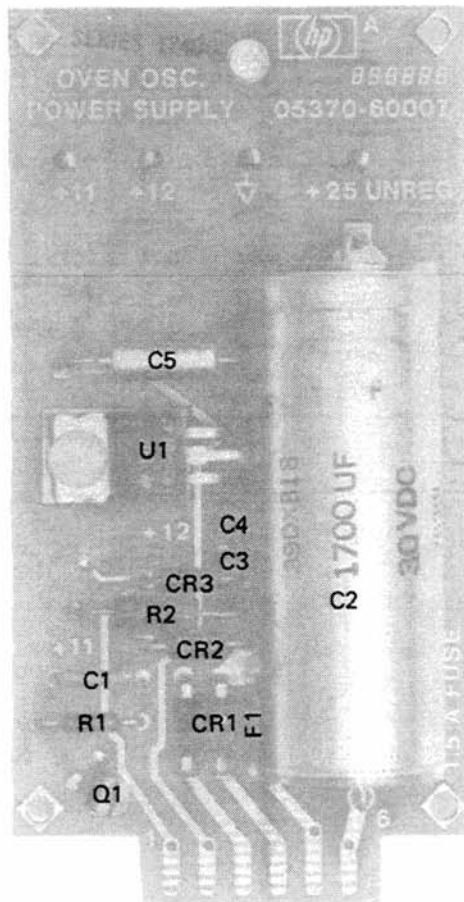

A7

First part of page 8-87 which folds out

A7 OSCILLATOR POWER SUPPLY (05370-60007) SERIES 2648

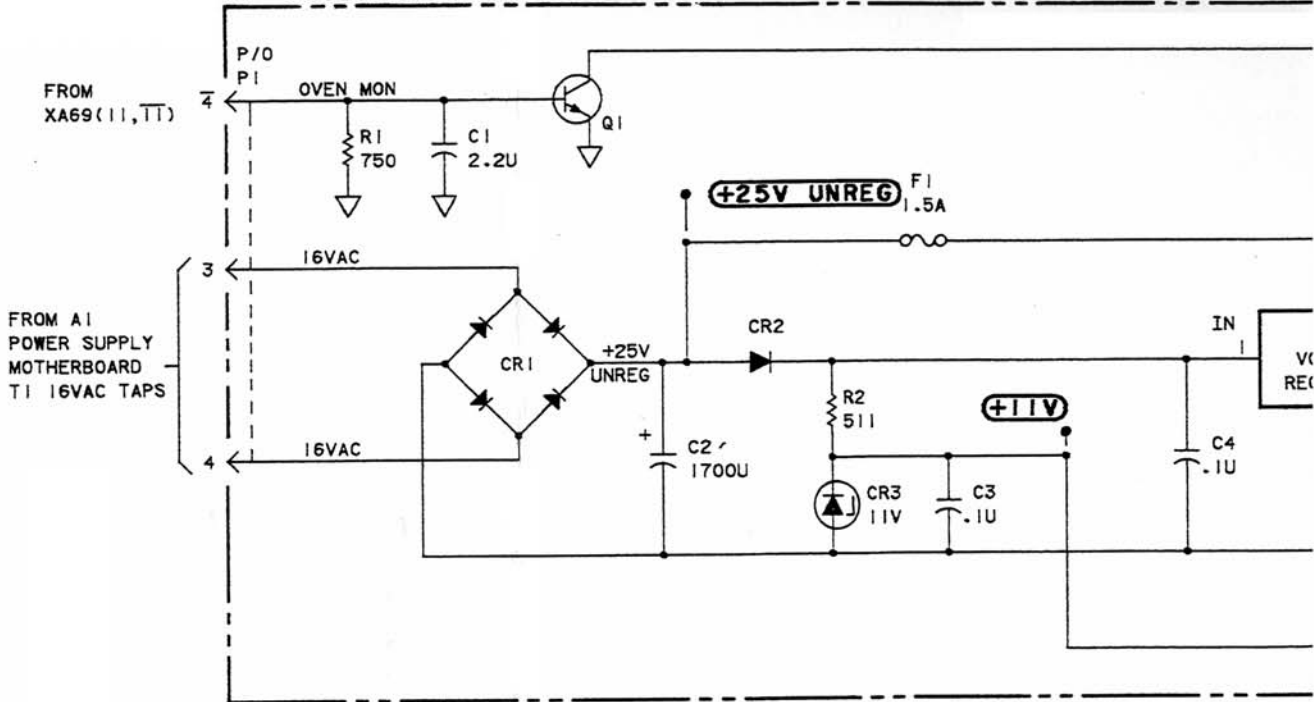

NOTES

1. REFERENCE DESIGNATIONS WITHIN THIS ASSEMBLY ARE ABBREVIATED. ADD ASSEMBLY NUMBER TO ABBREVIATION FOR COMPLETE DESCRIPTION.
2. UNLESS OTHERWISE INDICATED:
RESISTANCE IN OHMS
CAPACITANCE IN FARADS
INDUCTANCE IN HENRIES
3. ASTERISK (*) INDICATES SELECTED COMPONENT, AVERAGE VALUES SHOWN.

Second part of page 8-87 which folds out

.Y (05370-60007) SERIES 2648

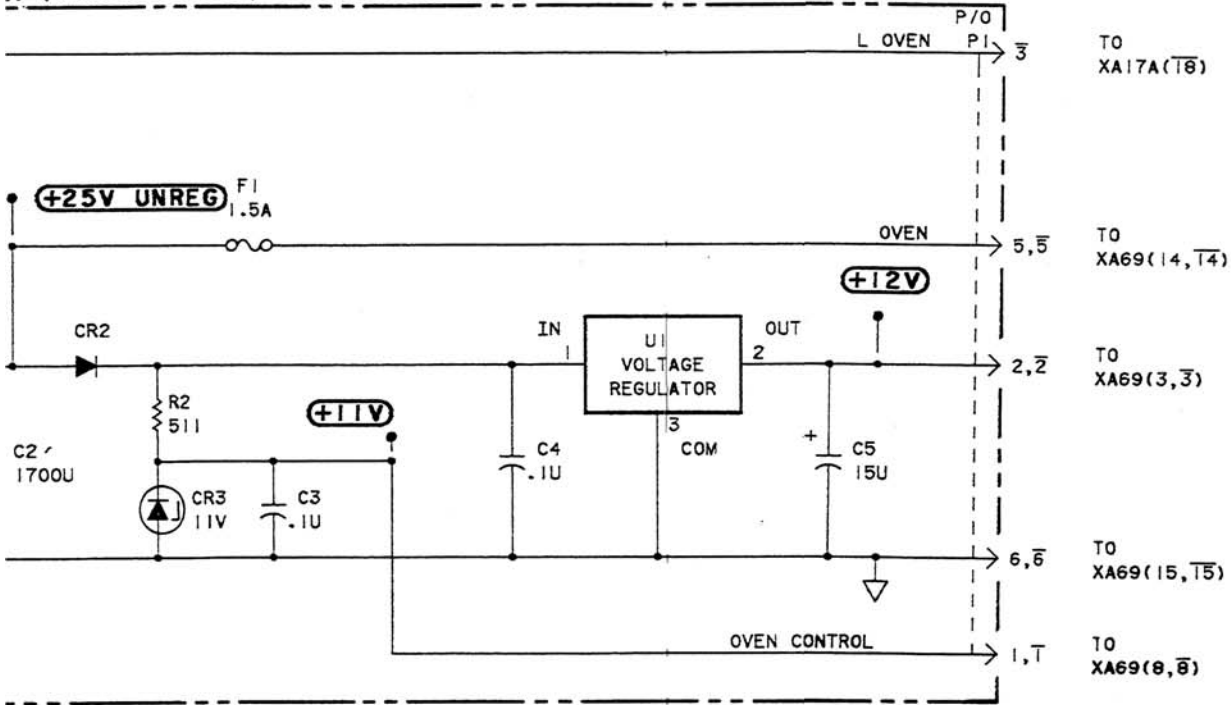

IN THIS
D ASSEMBLY
COMPLETE

SHOWN.

Figure 8-24. A7 Oven Oscillator Supply Amplifier Assembly

Third (and final) part of page 8-87 which folds out Page 8-87

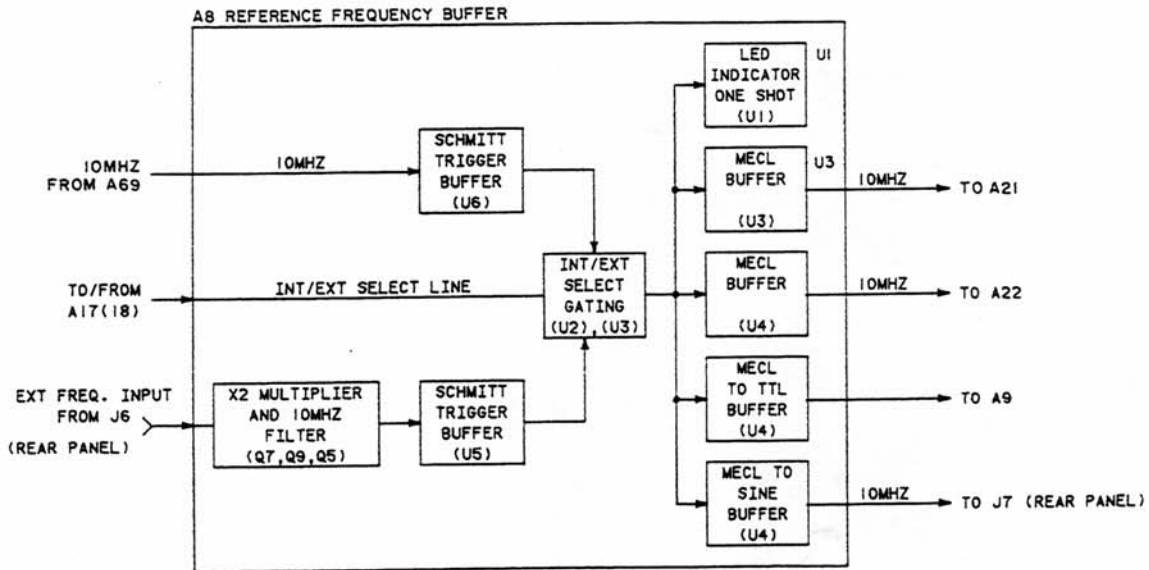

A8 REFERENCE FREQUENCY BUFFER ASSEMBLY

The Reference Frequency Buffer Assembly (A8) receives 10 MHz from either of two sources. The first source is the internal crystal time base. The second source is the EXTERNAL frequency input (5 or 10 MHz) from the rear panel connector J6. Whichever 10 MHz signal is selected is shaped and sent to four buffers and a signal monitor. The monitor is an LED and a one-shot multi-vibrator triggered by the 10 MHz signal. When the LED indicator is on, the selected source signal is present.

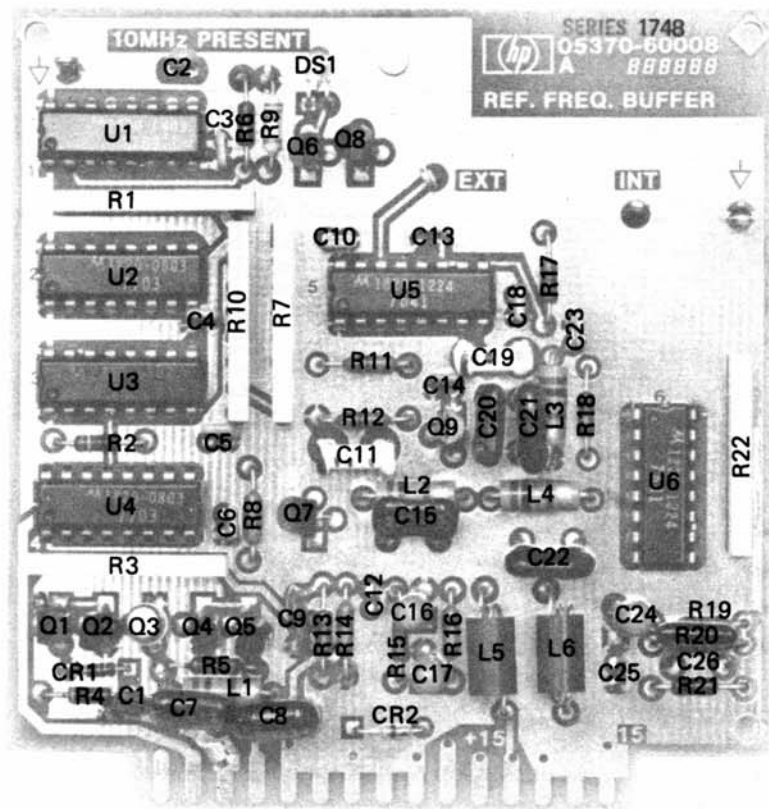

A8

First part of page 8-89, which folds out.

A8 REFERENCE FREQUENCY BUFFER (05370-60008)

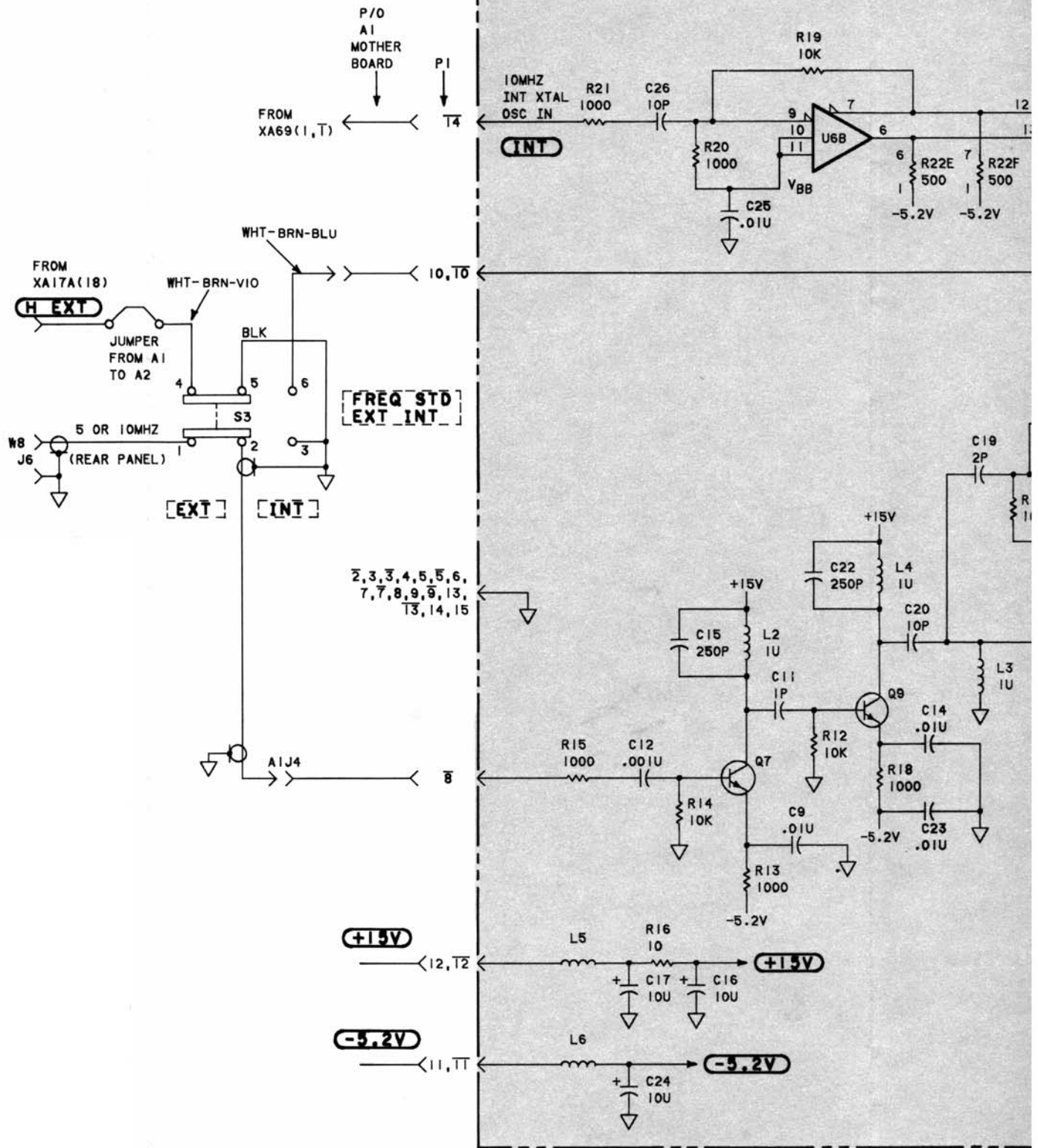

Second part of page 8-89, which folds out.

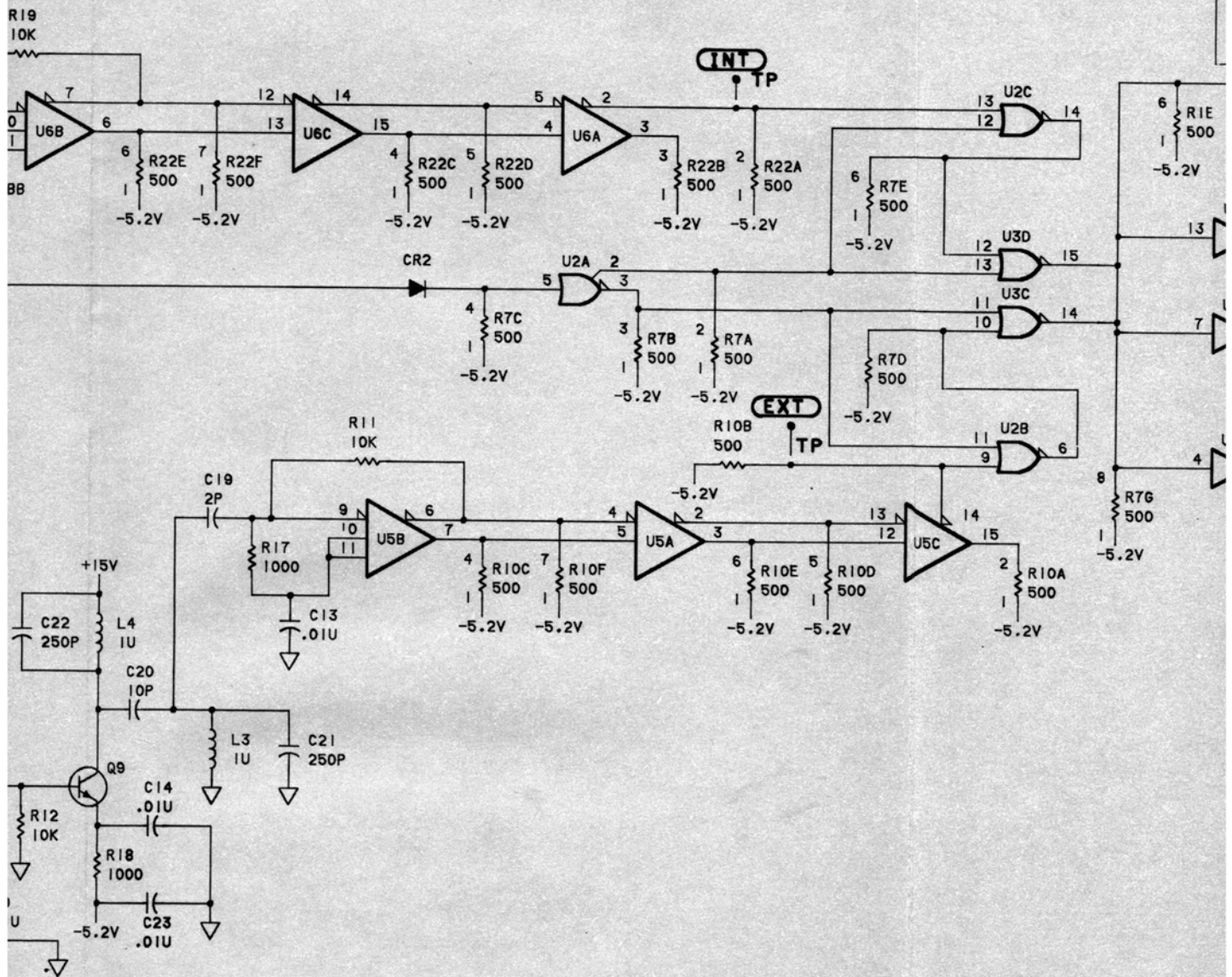

Third part of page 8-89, which folds out.

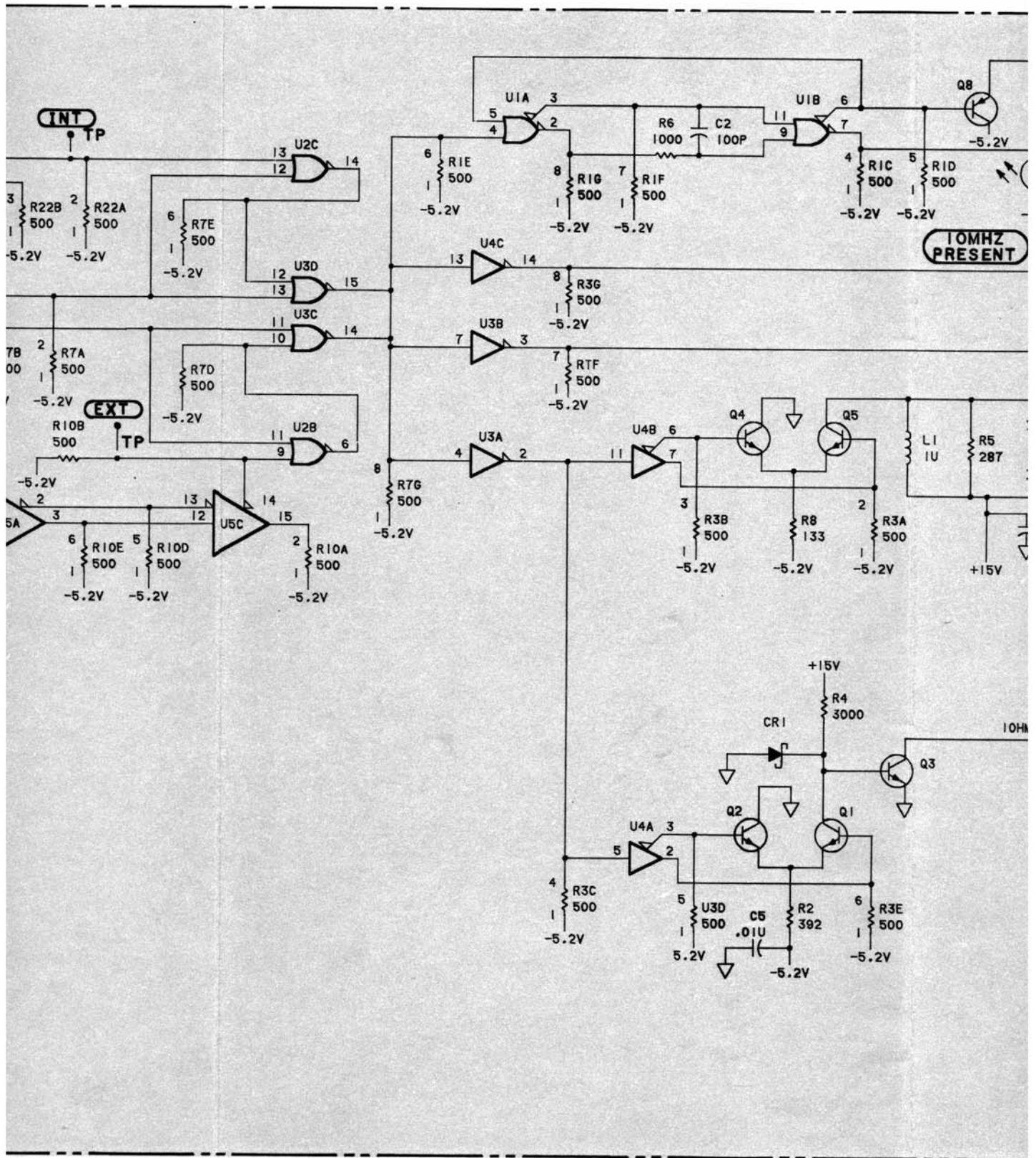

Fourth part of page 8-89, which folds out.

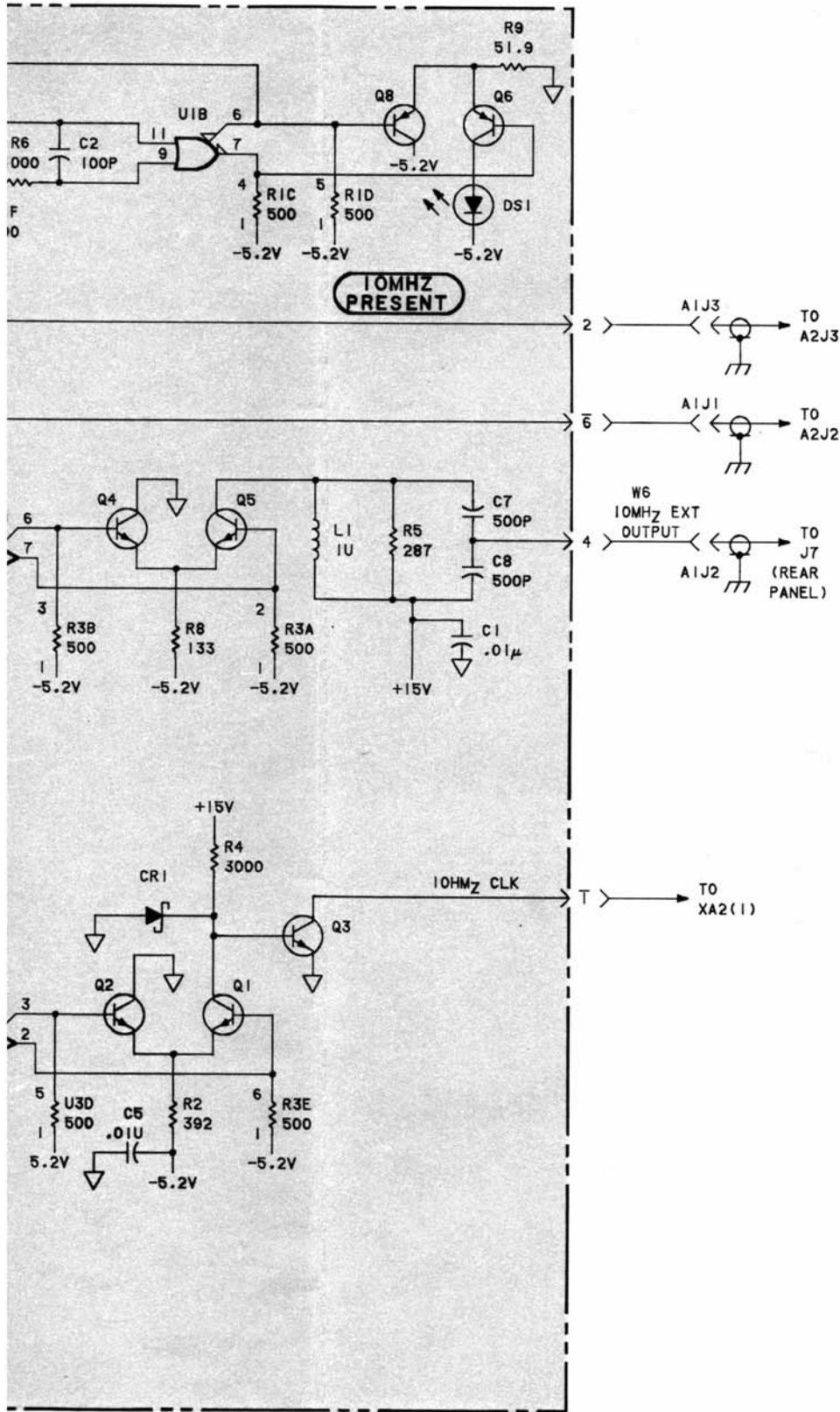

NOTES

1. REFERENCE DESIGNATIONS WITHIN THIS ASSEMBLY ARE ABBREVIATED. ADD ASSEMBLY NUMBER TO ABBREVIATION FOR COMPLETE DESCRIPTION.
2. UNLESS OTHERWISE INDICATED:
RESISTANCE IN OHMS
CAPACITANCE IN FARADS
INDUCTANCE IN HENRIES
3. ASTERISK (*) INDICATES SELECTED COMPONENT, AVERAGE VALUES SHOWN.

Figure 8-25. A8 Reference Frequency Buffer Assembly

Fifth (and final) part of page 8-89, which folds out.

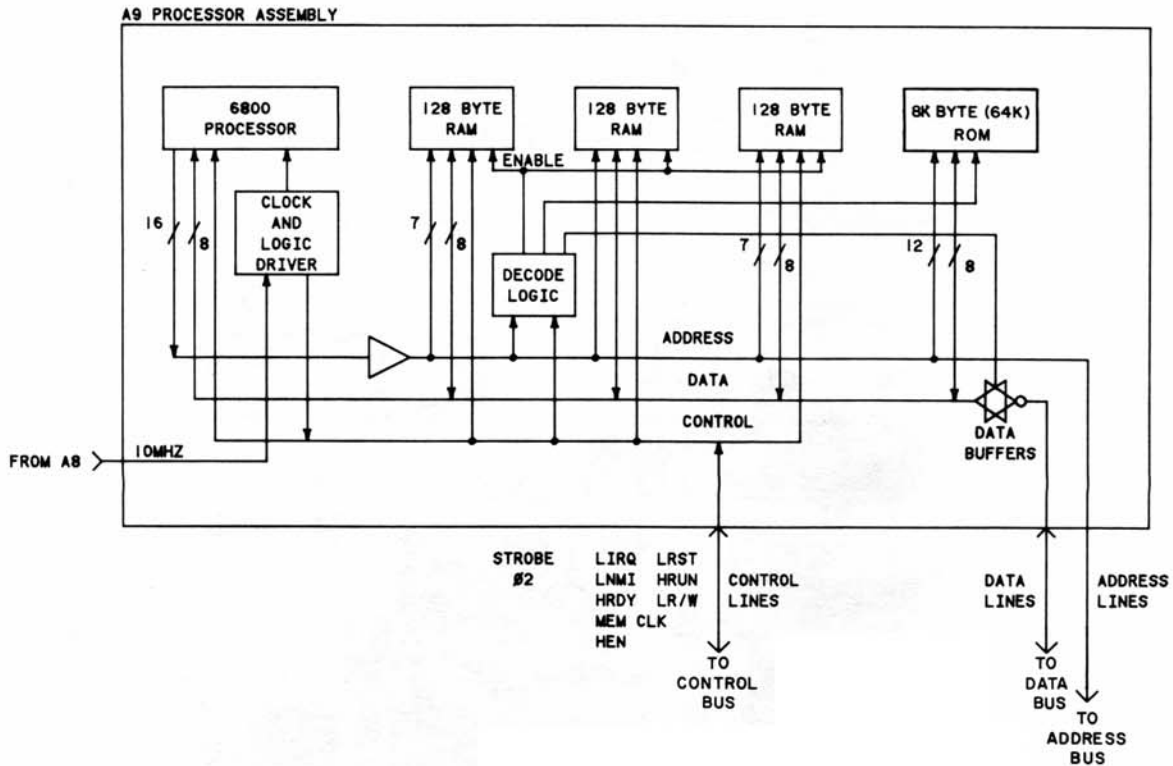

A9 PROCESSOR ASSEMBLY

The Processor Assembly (A9) contains the microprocessor; clock logic and driver circuits; RAM and RAM Address Decode logic; ROM; and, Address and Data Buffers. The Address Bus contains 16 lines which can address up to 65K locations. They are one direction (out only). The data bus contains 8 lines. These are bidirectional (Input and Output) to the A9 Assembly.

The third bus is the control bus. The lines are mainly microprocessor inputs with the exception of three. The R/W (Read/Write) lines is an output to the RAMs. The VMA (Valid Memory Address) lines is used for decoding. And the BA (Bus Available) line used to tell assemblies on the Address Bus, the bus is not being used by the microprocessor. The remaining control lines enable the microprocessor to keep track of the status of the rest of the machine. For example, these lines enable the machine to use the HP-IB and lets the microprocessor know when a key is pressed or when a measurement has been completed. The RAMs are used to store data such as which key is active or the results of previous measurements. The ROM contains all the microprocessor operating instructions.

The 10 MHz is present from the A8 Frequency Buffer Assembly to run the Microprocessor Clock State Machine, which generates all necessary processor clocks.

Part of Figure 8-26. A9 Processor Assembly

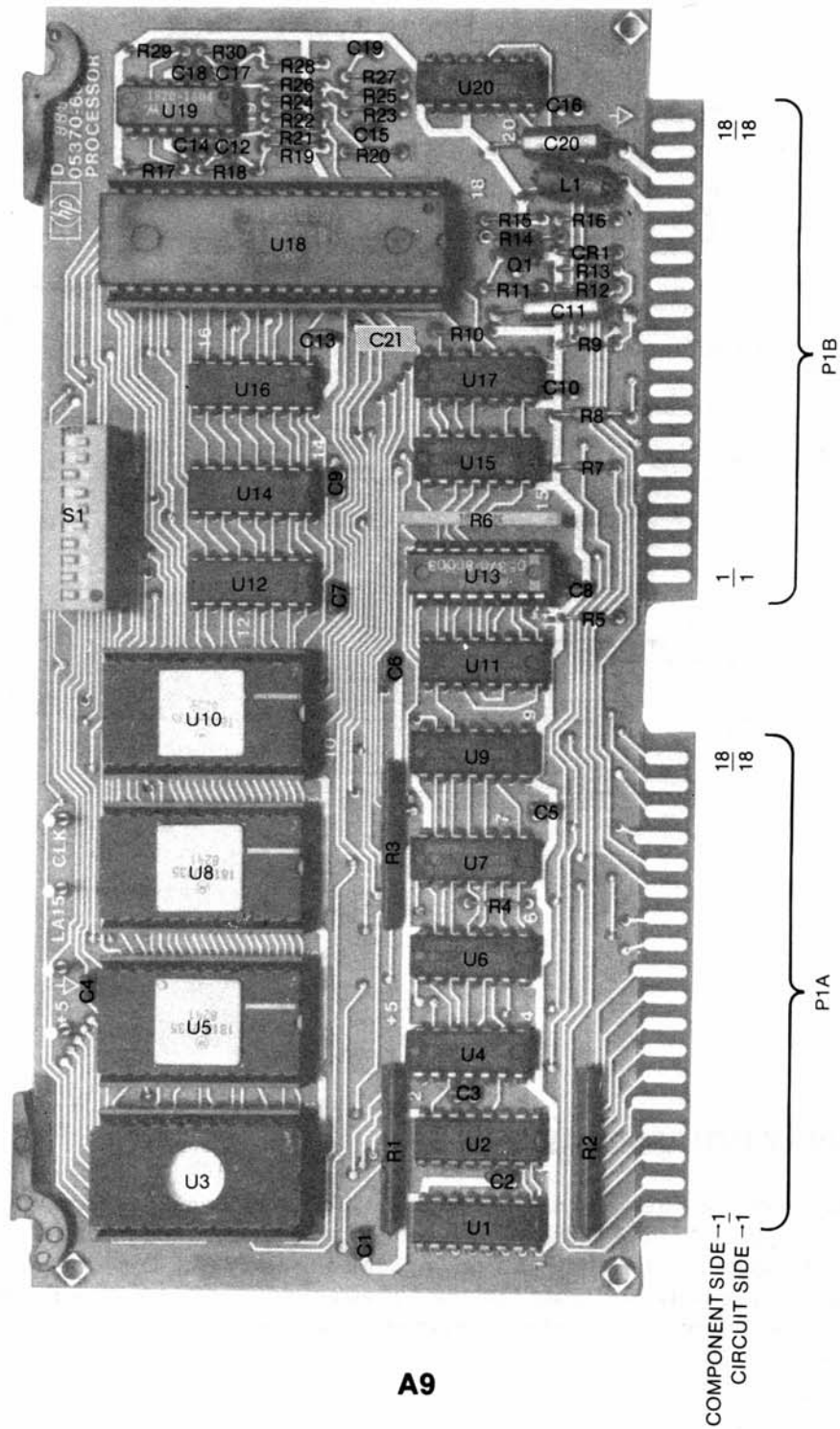

A9

First part of page 8-91, which folds out.

A9 PROCESSOR ASSEMBLY (Serial Number 2904A02371 and above)

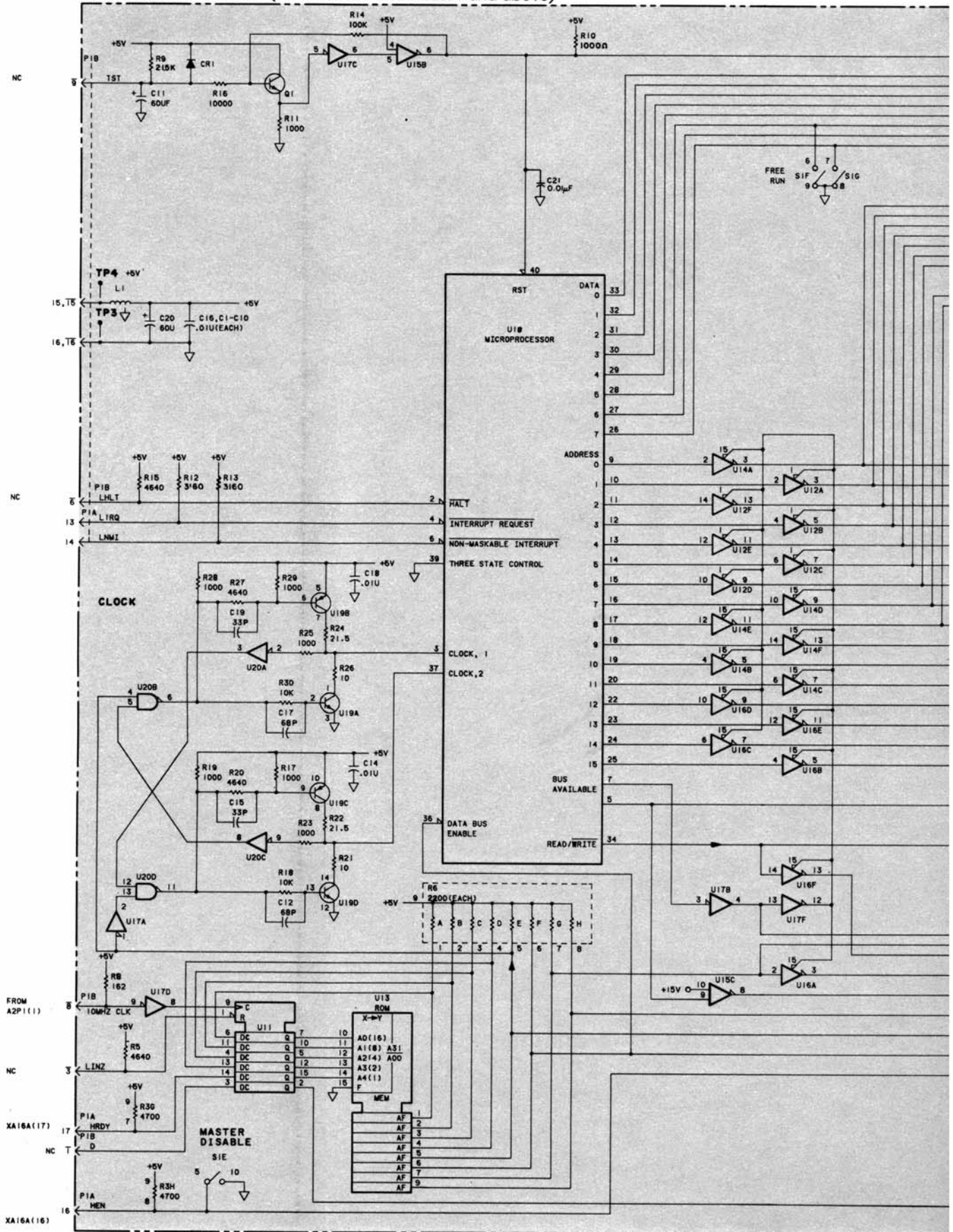

Second part of page 8-91, which folds out.

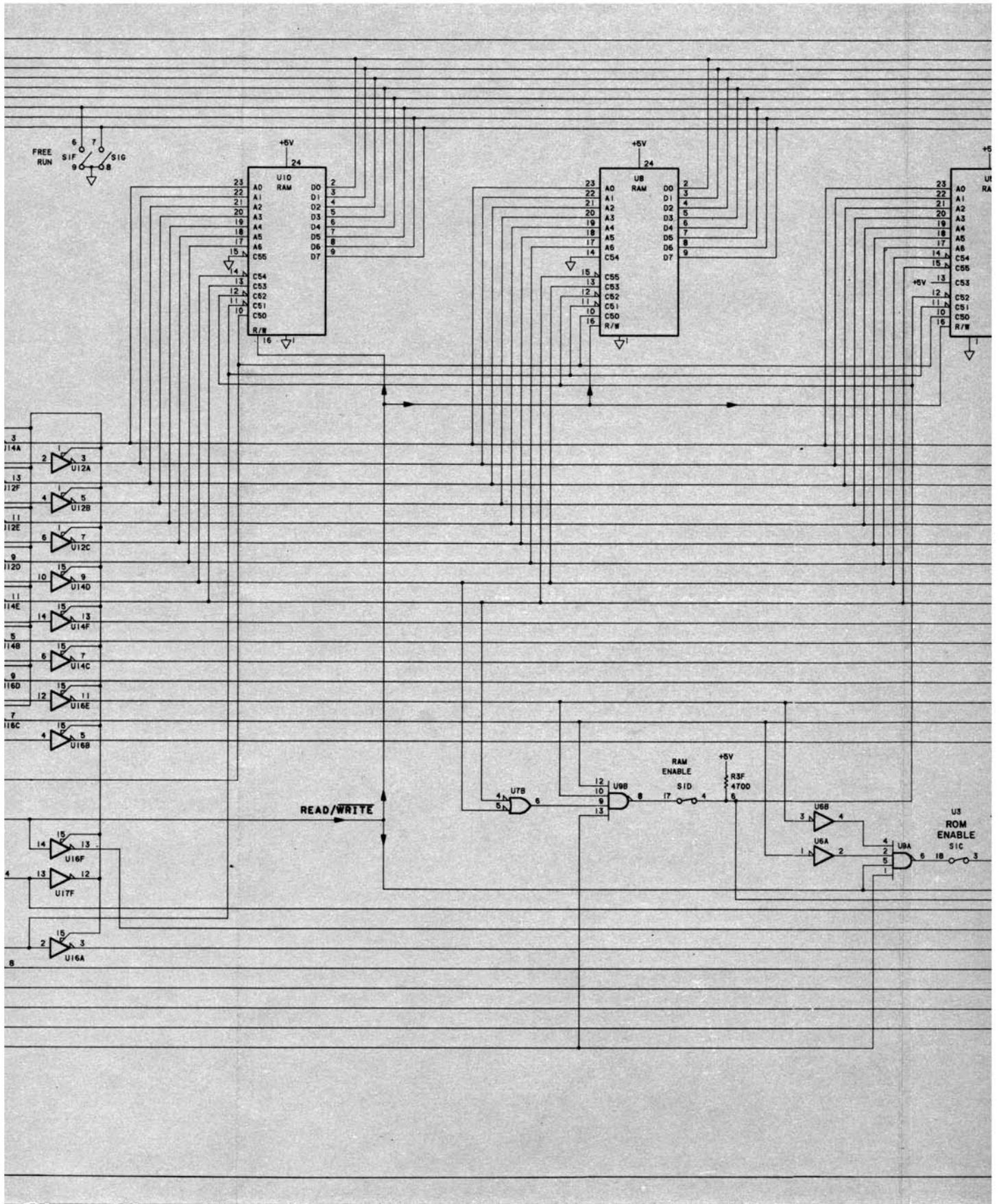

Third part of page 8-91, which folds out.

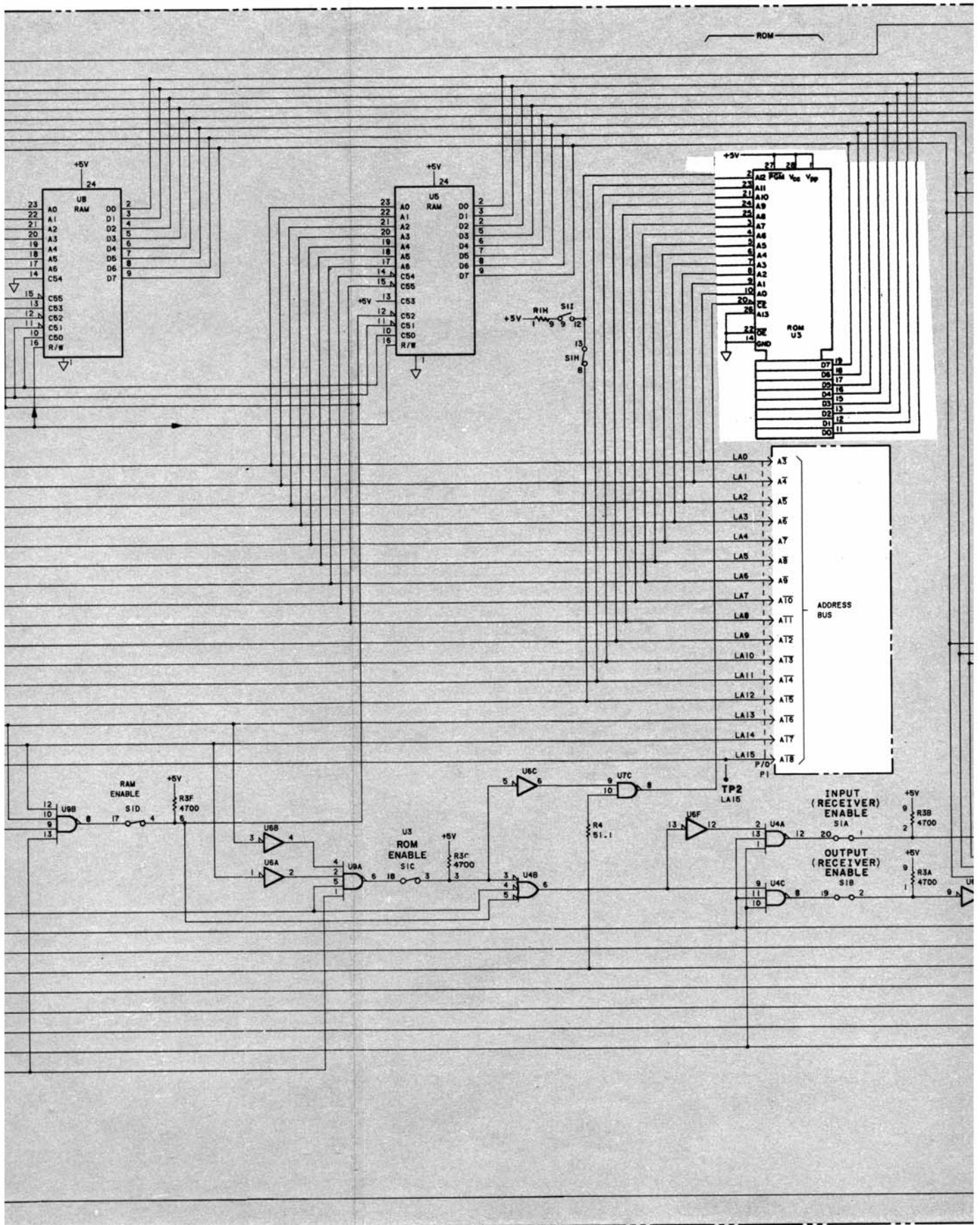

Fourth part of page 8-91, which folds out.

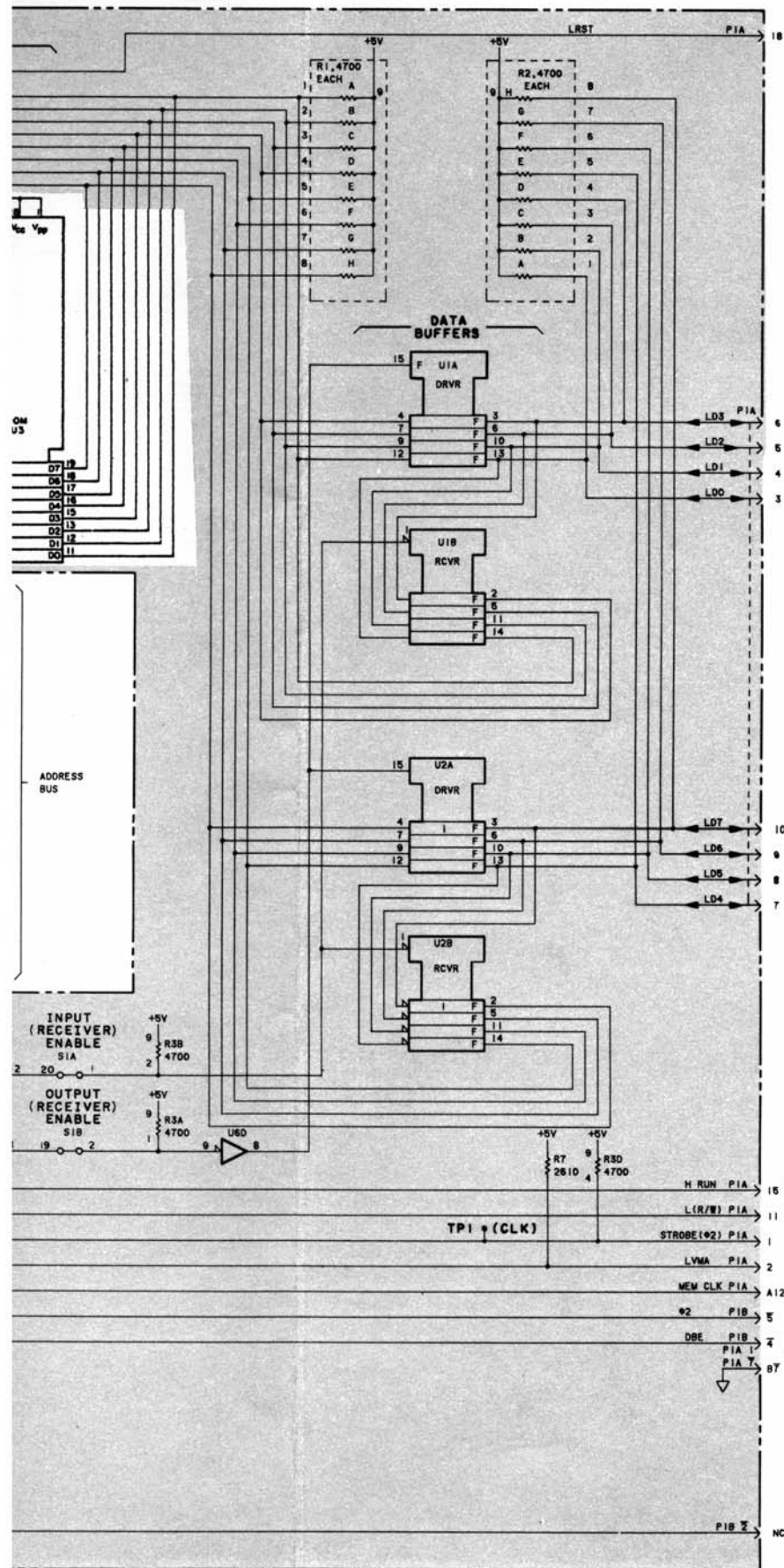

- NOTES
1. REFERENCE DESIGNATIONS WITHIN THIS ASSEMBLY ARE ABBREVIATED. ADD ASSEMBLY NUMBER TO ABBREVIATION FOR COMPLETE DESCRIPTION
 2. UNLESS OTHERWISE INDICATED: RESISTANCE IN OHMS CAPACITANCE IN FARADS INDUCTANCE IN HENRIES
 3. ASTERISK (*) INDICATES SELECTED COMPONENT AVERAGE VALUES SHOWN

Figure 8-26. A9 Processor Assembly

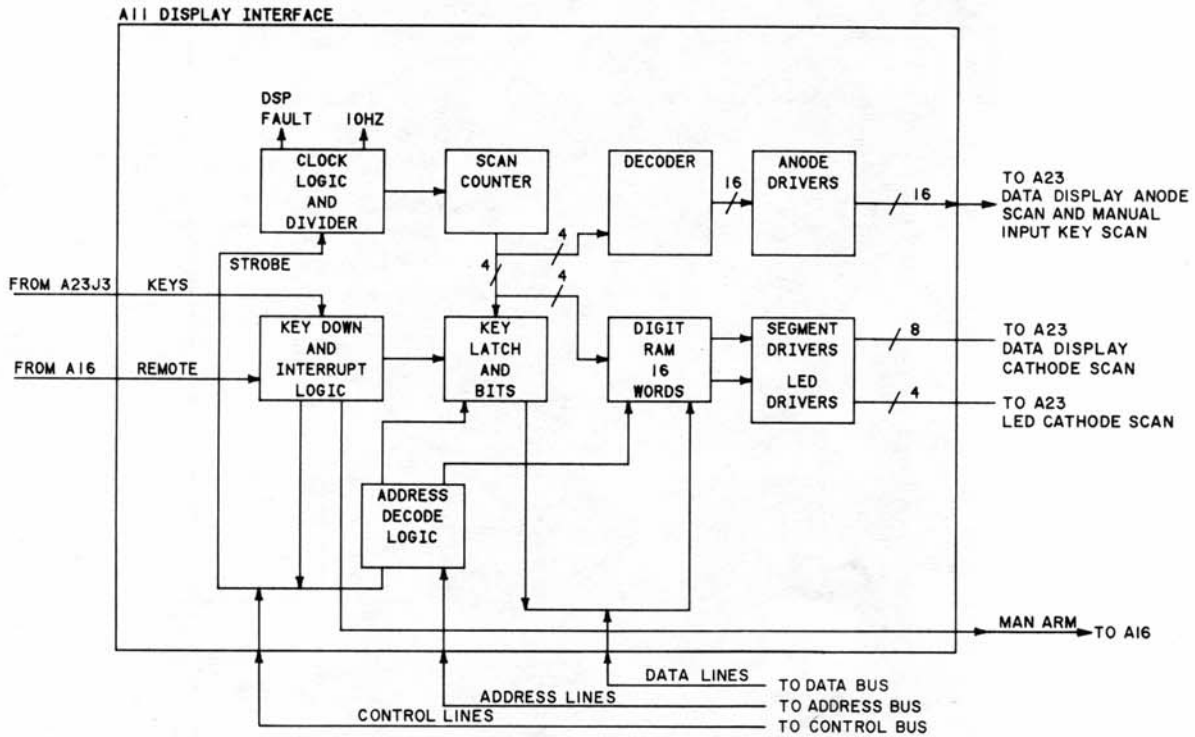

A11 DISPLAY INTERFACE ASSEMBLY

The Display Interface Assembly (A11) allows the microprocessor (A9) to communicate with the display and keyboard. The A11 Assembly is connected directly to the machine's internal processor bus. All logic for decoding and driving, and the latch and RAM for the key data and display data, respectively, are located on the A11 assembly. The RAMs store the previous measurement result during the current measurement cycle. This data is sent to the Display/Control Panel Assembly (A23).

Part of Figure 8-27. A11 Display Interface Assembly

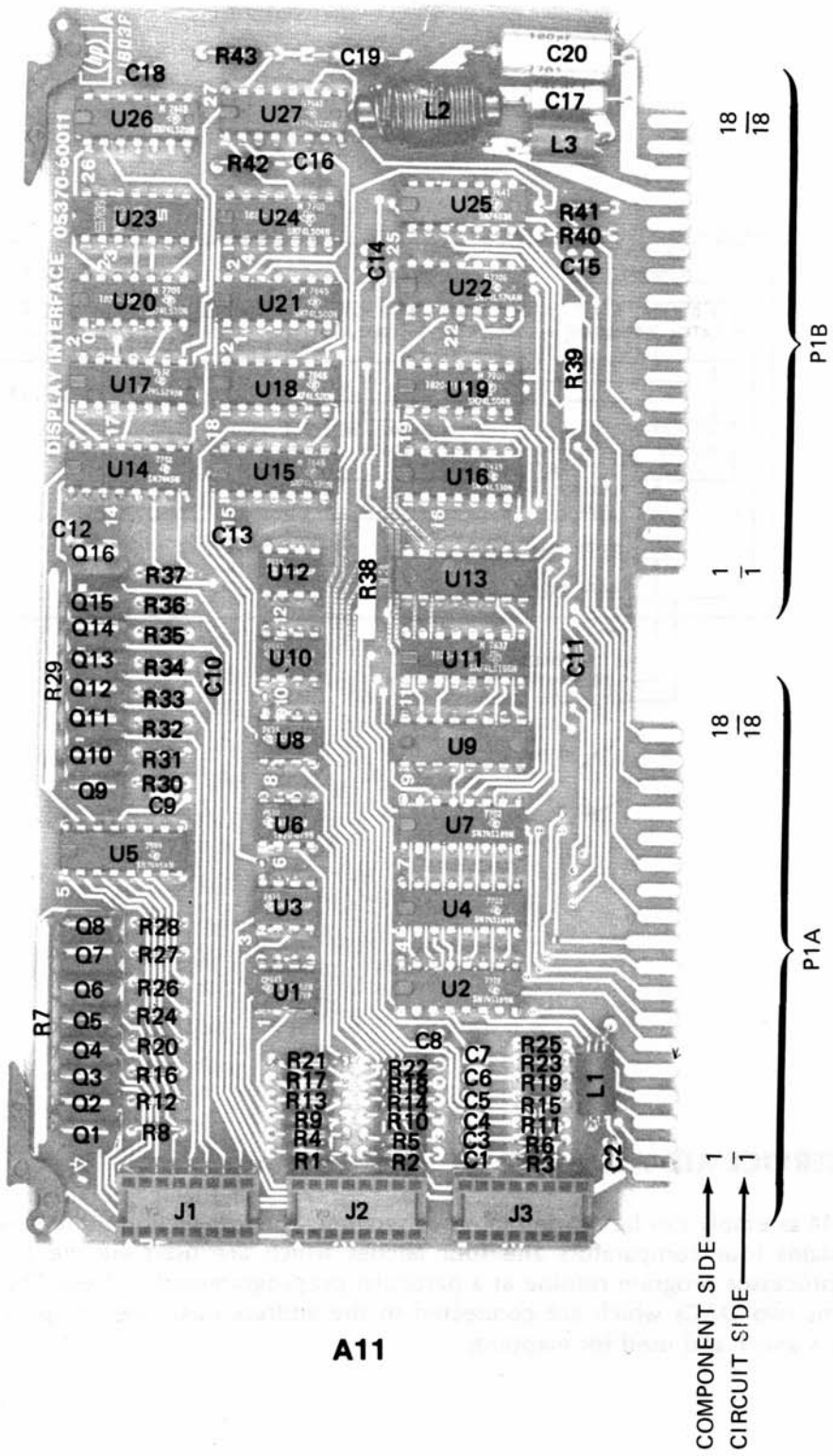

A11

First part of page 8-93, which folds out.

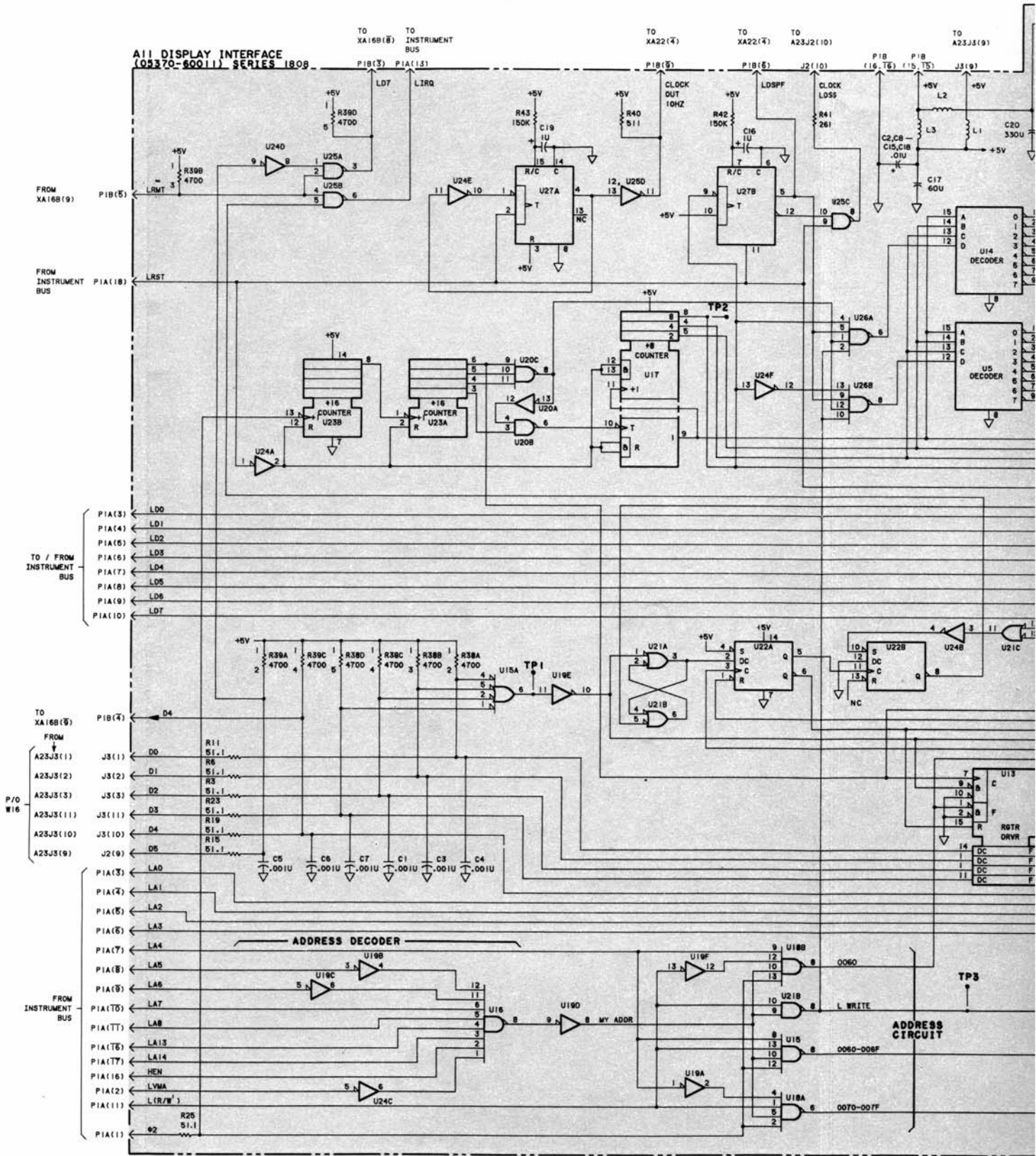

Second part of page 8-93, which folds out.

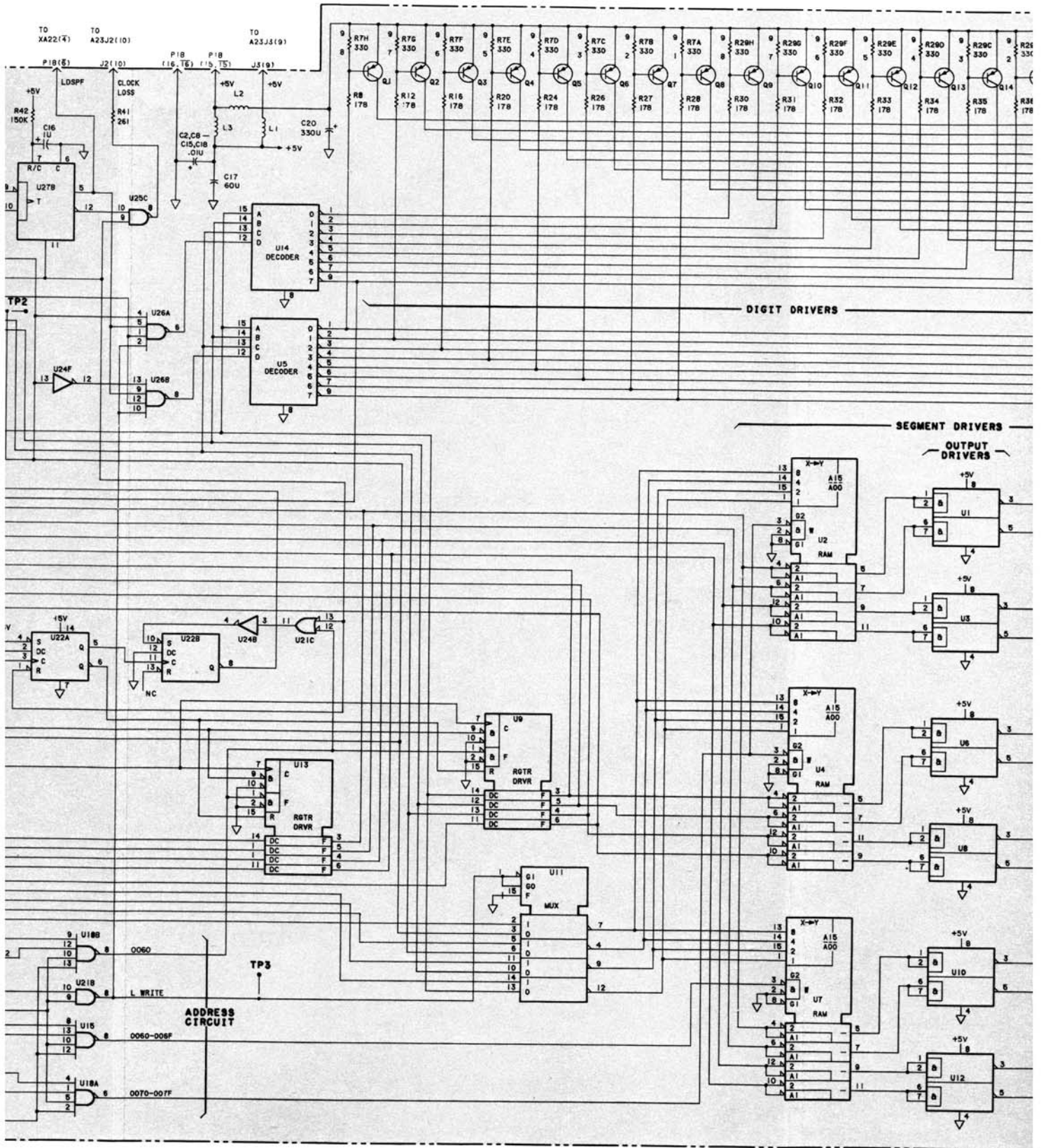

Third part of page 8-93, which folds out.

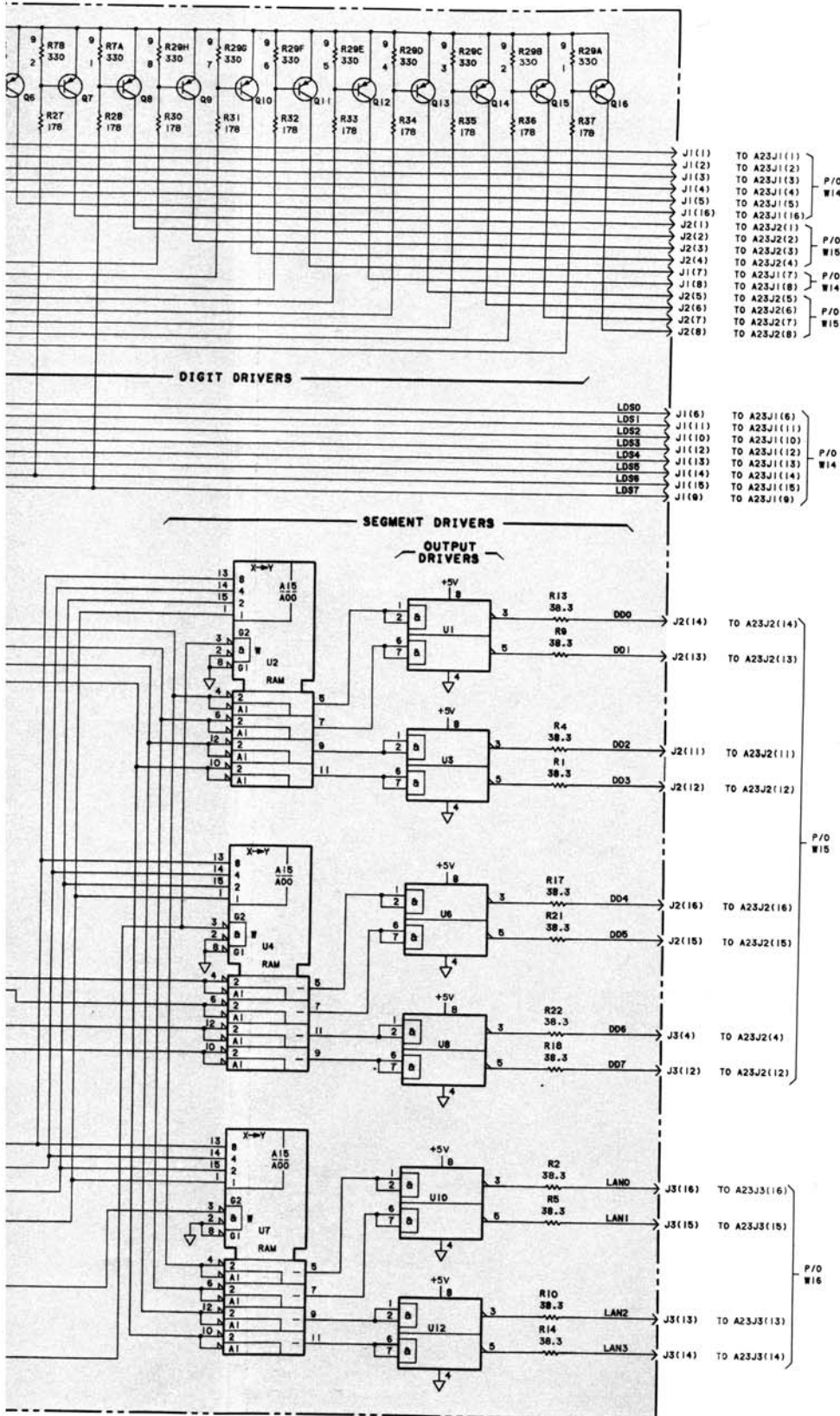

- NOTES
1. REFERENCE DESIGNATIONS WITHIN THIS ASSEMBLY ARE PREVIATED. ADD ASSEMBLY NUMBER TO ABBREVIATION FOR COMPLETE DESCRIPTION.
 2. UNLESS OTHERWISE INDICATED RESISTANCE IN OHMS CAPACITANCE IN FARADS INDUCTANCE IN HENRIES
 3. ASTERISK (*) INDICATES SELECTED COMPONENT, AVERAGE VALUES SHOWN.

Figure 8-27. A11 Display Interface Assembly

Fourth (and final) part of page 8-93, which folds out.

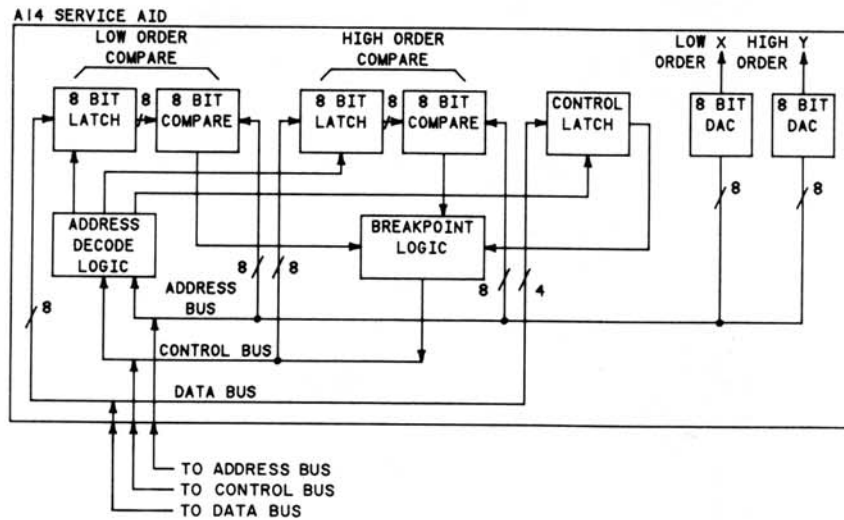

A14 SERVICE AID ASSEMBLY

The A14 assembly can be divided into two sections. The first section is the breakpoint section. It contains four comparators and four latches which are used via the HP-IB to halt the microprocessor program routine at a particular preprogrammed address. The second section contains two DACs which are connected to the address bus. Their outputs are fed to test points X and Y and used for mapping.

Part of Figure 8-28. A14 Service Aid Assembly

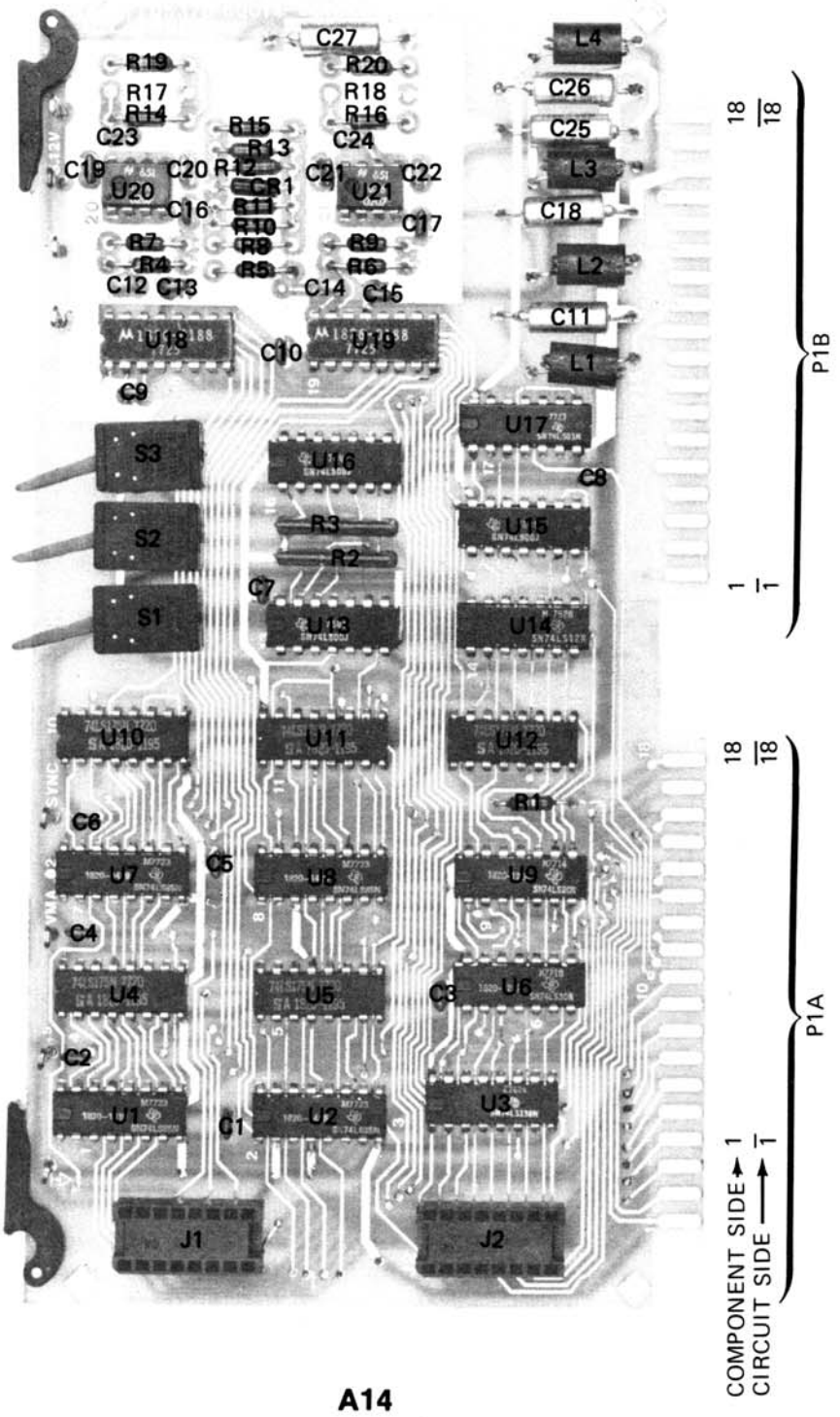

First part of page 8-95, which folds out.

A14 SERVICE AID ASSEMBLY (05370-60014) SERIES 1748

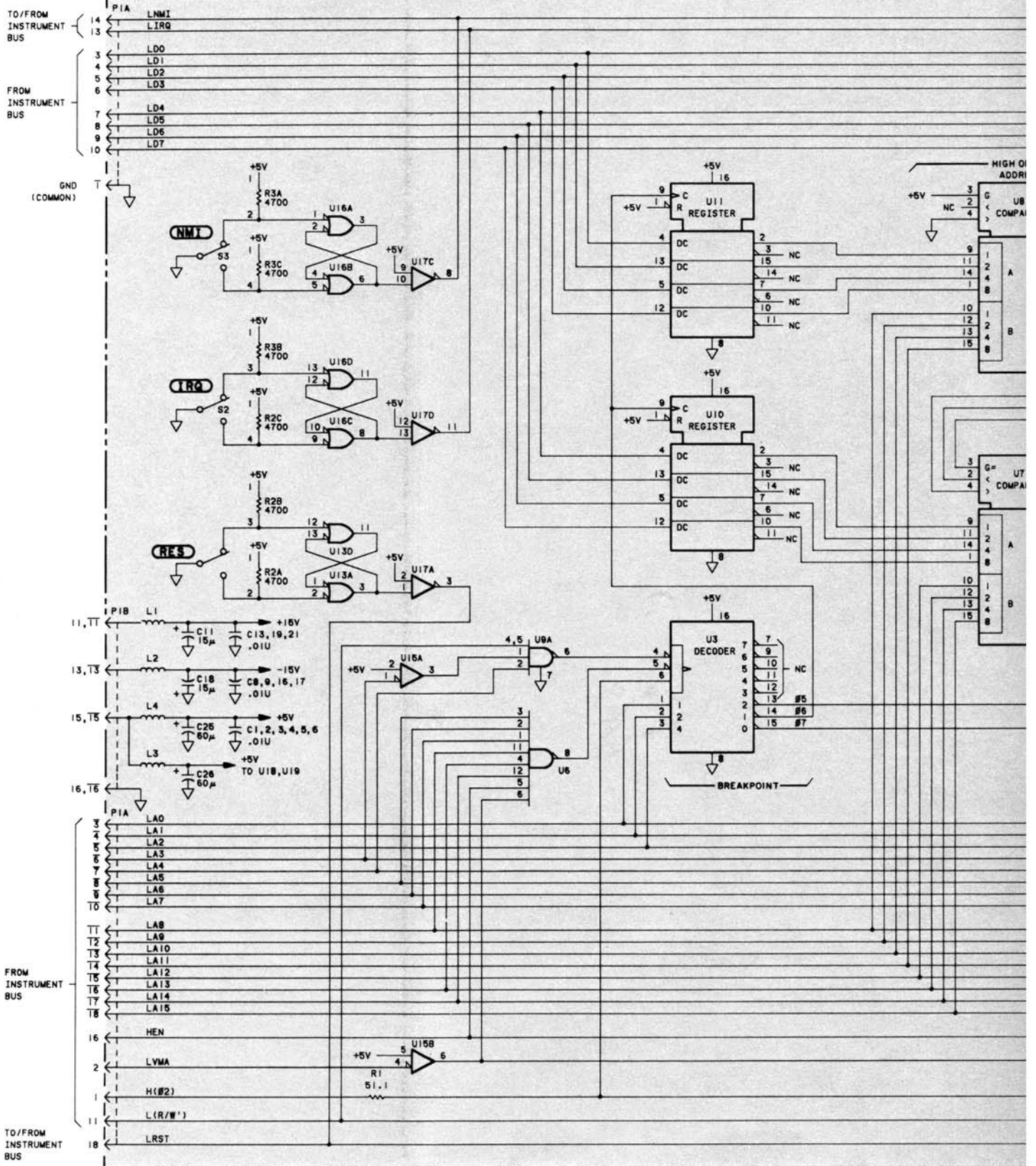

Second part of page 8-95, which folds out.

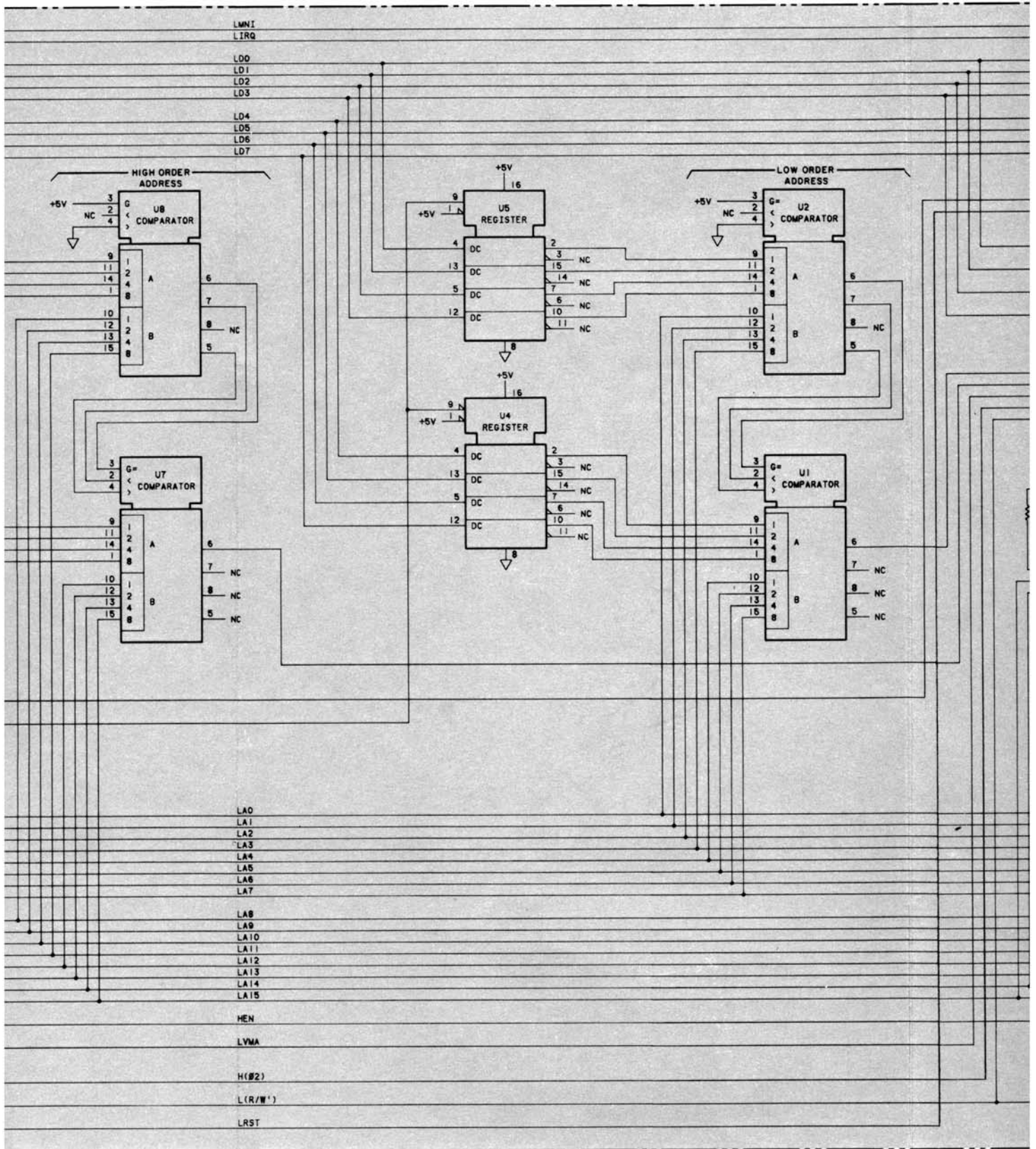

Third part of page 8-95, which folds out.

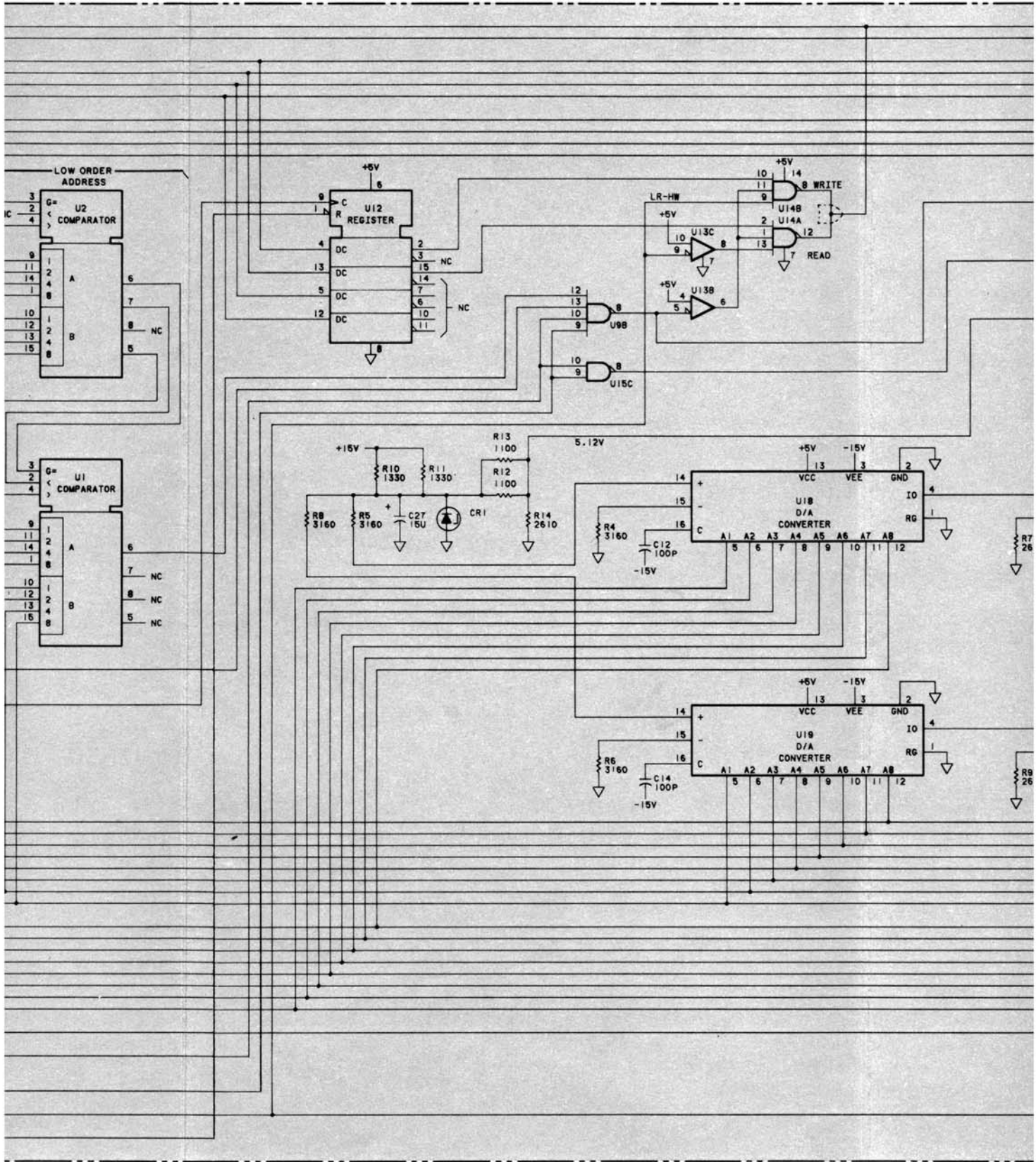

Fourth part of page 8-95, which folds out.

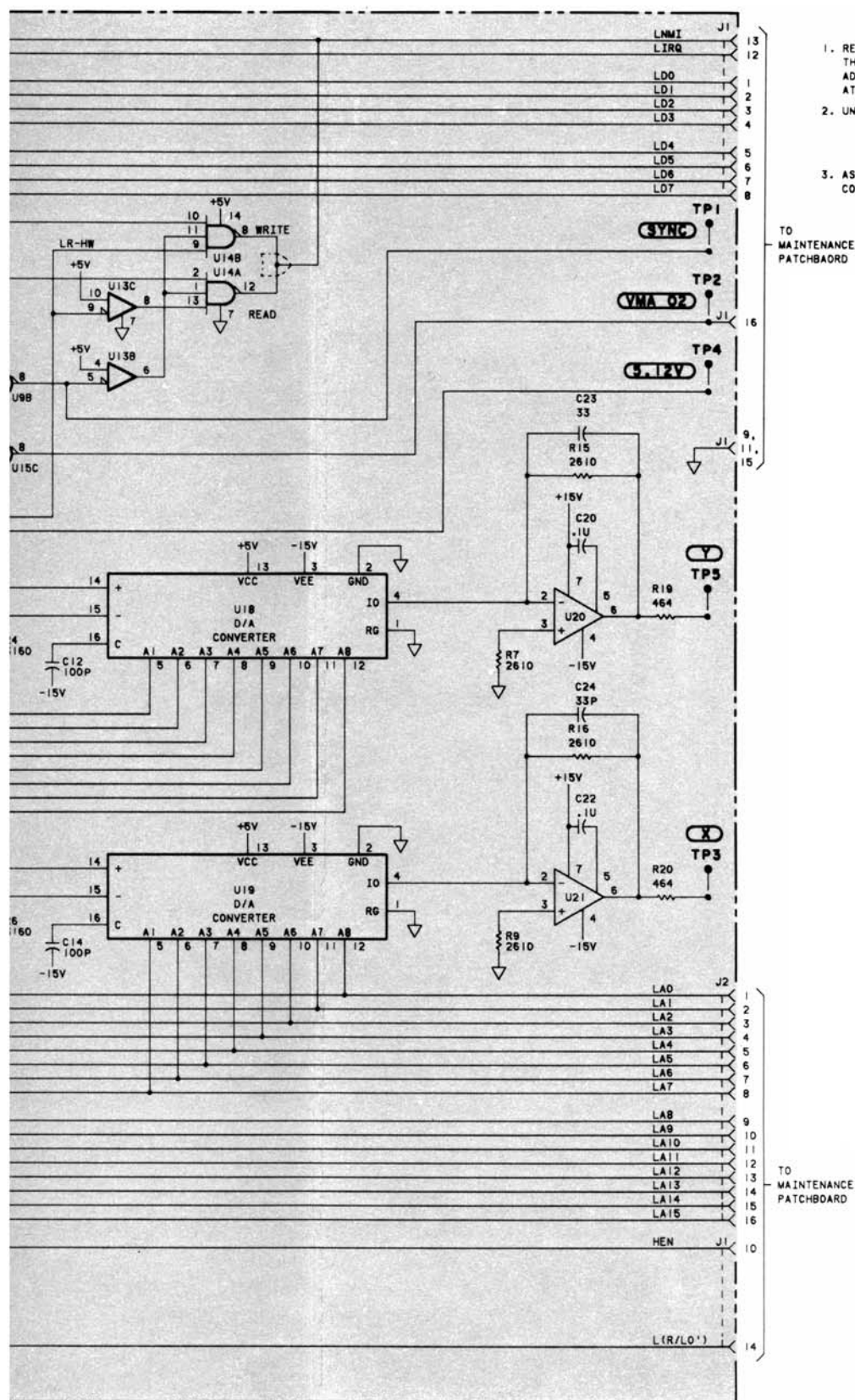

- NOTES
1. REFERENCE DESIGNATIONS WITHIN THIS ASSEMBLY ARE ABBREVIATED. ADD ASSEMBLY NUMBER TO ABBREVIATION FOR COMPLETE DESCRIPTION.
 2. UNLESS OTHERWISE INDICATED: RESISTANCE IN OHMS CAPACITANCE IN FARADS INDUCTANCE IN HENRIES
 3. ASTERISK (*) INDICATES SELECTED COMPONENT, AVERAGE VALUES SHOWN.

TO MAINTENANCE PATCHBOARD

TO MAINTENANCE PATCHBOARD

Figure 8-28. A14 Service Aid Assembly (Part of Service Accessory Kit P/N 10870A)

A5 HP-IB CONNECTOR ASSEMBLY

The A5 assembly provides the interconnection between A15 and the interface bus. Switch S1 is used to select the address code for the instrument.

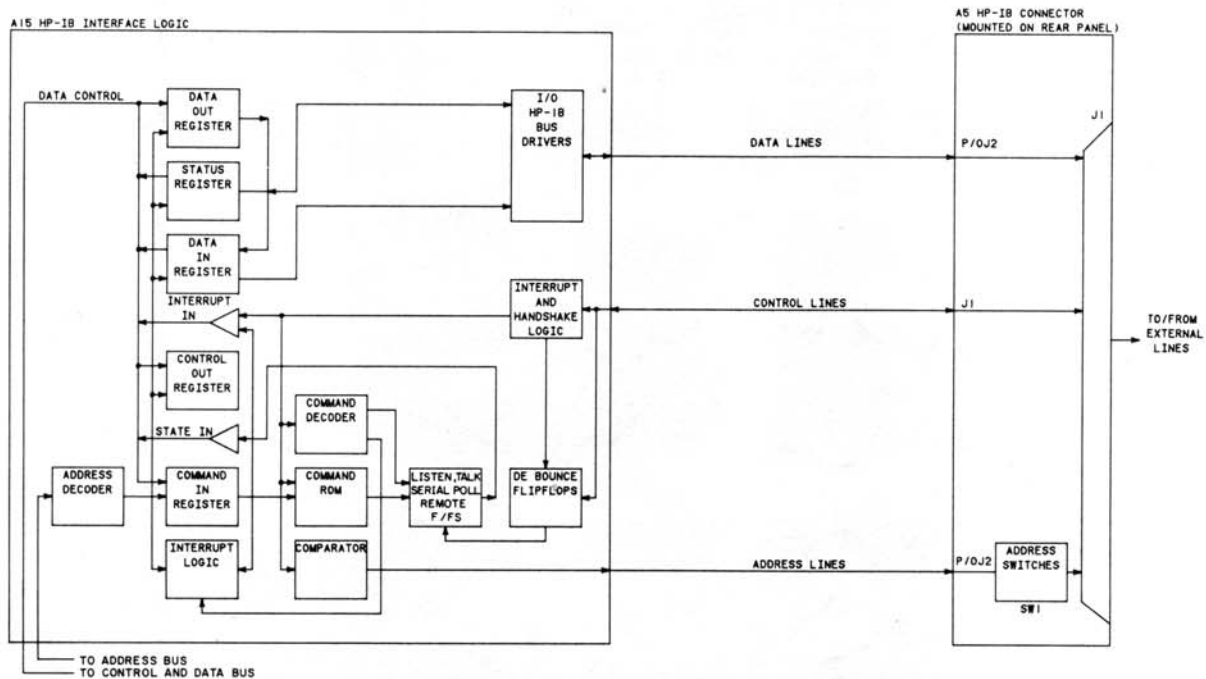

A15 HP-IB INTERFACE LOGIC ASSEMBLY

The HP-IB Interface Logic Assembly (A15) serves as an interface between the 5370A and an external controller via the HP Interface Bus. The A15 assembly consists of seven interface registers (which are used by the microprocessor for interpreting commands and data, sending status, sending data, interpreting interrupts, etc.), two command decoding ROMs, and source and acceptor handshake circuitry.

Part of Figure 8-29. A15 HP-IB Interface Logic Assembly/A5 HP-IB Connector Assembly

A15 HP-IB INTERFACE (05370-60015) Series 2732

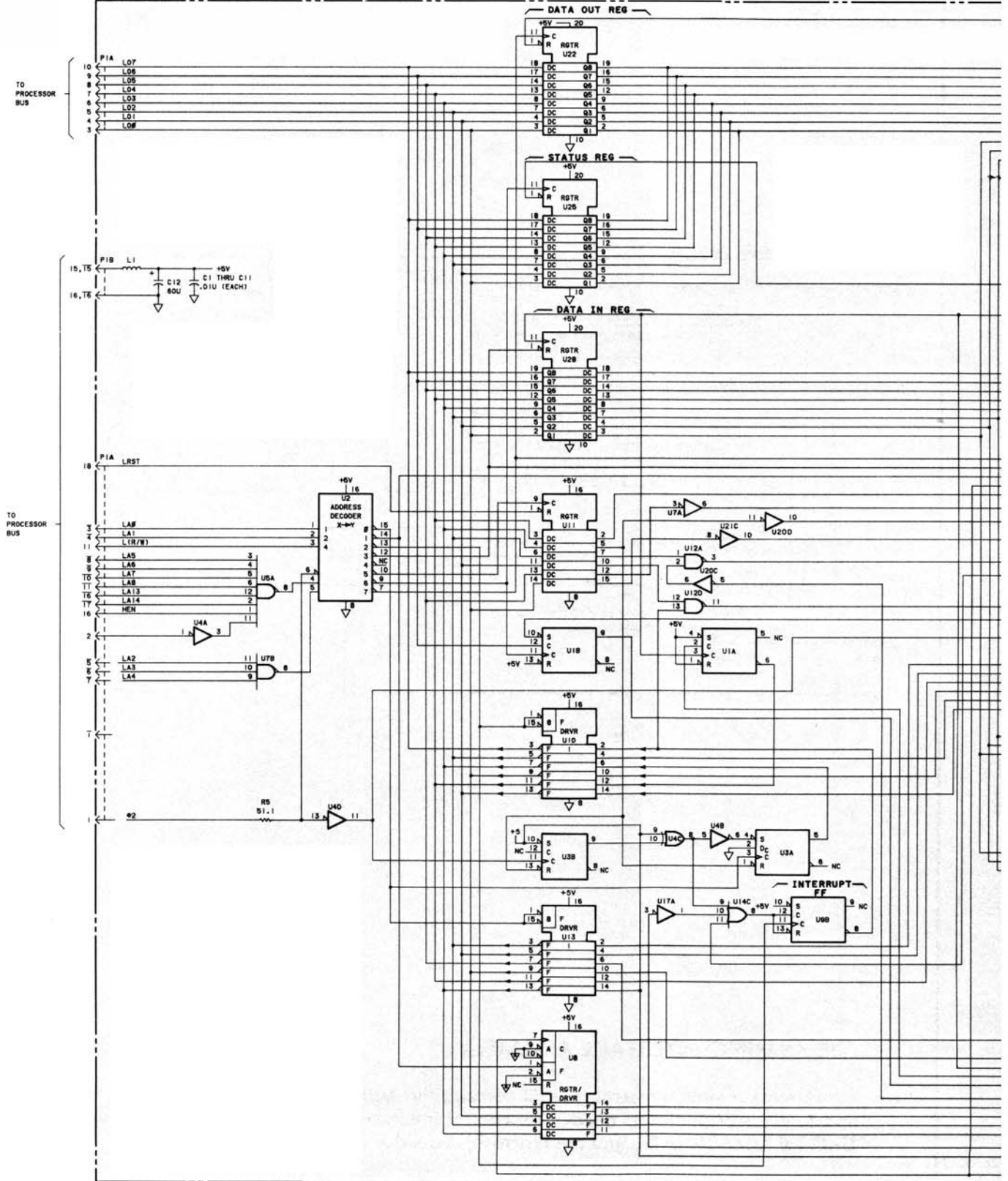

First part of page 8-97, which folds out.

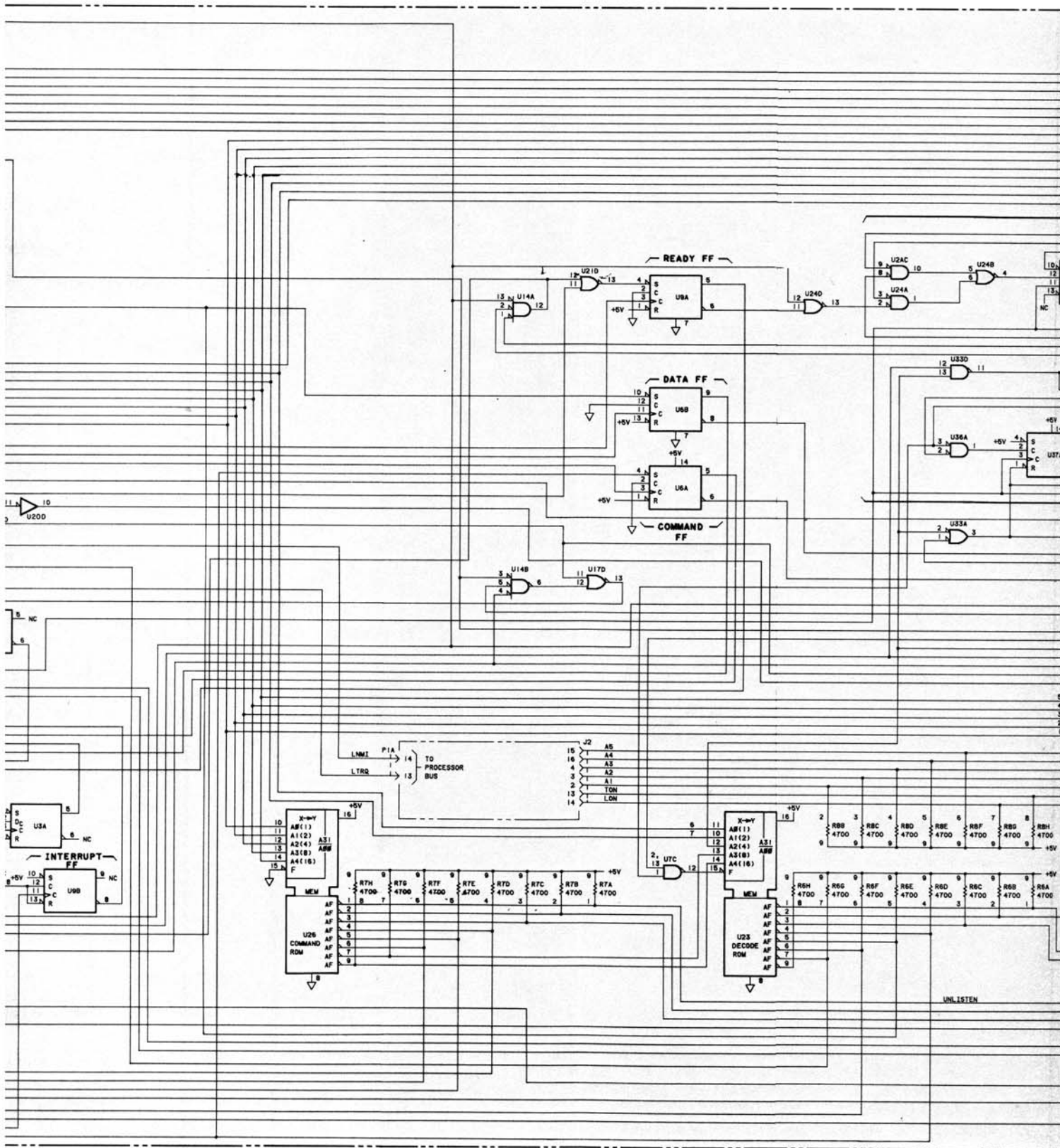

Second part of page 8-97, which folds out.

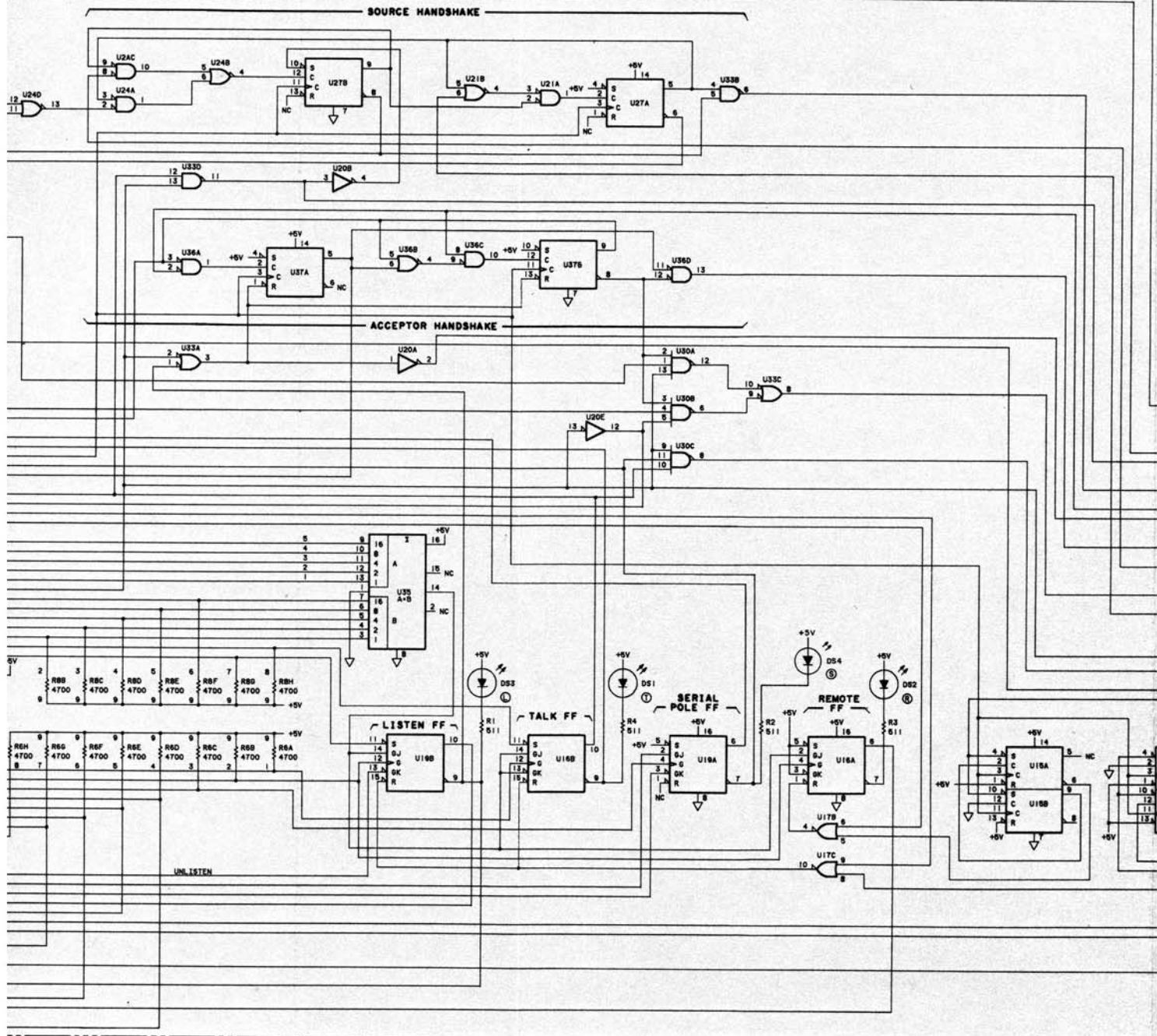

Third part of page 8-97, which folds out.

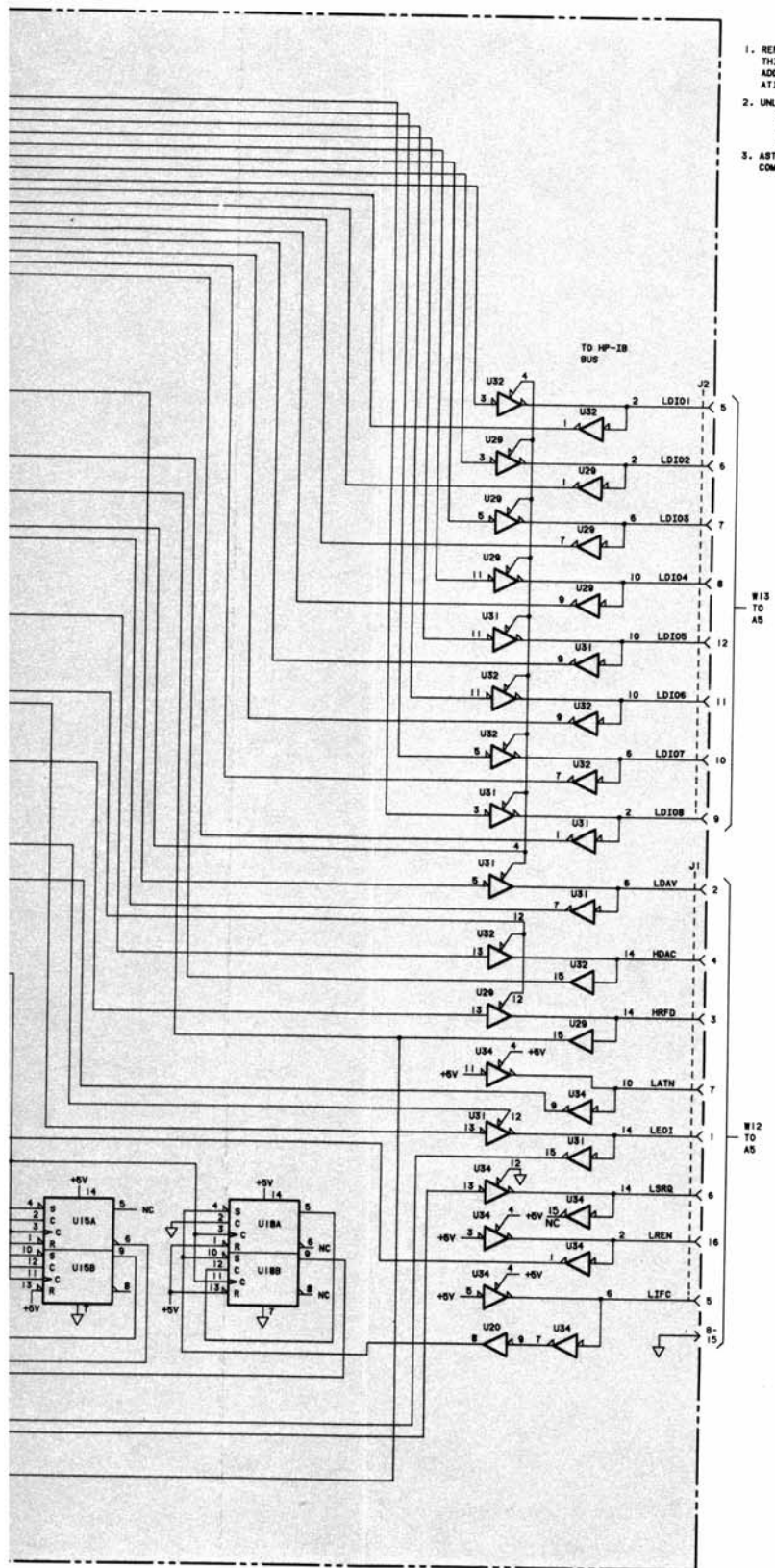

- NOTES
1. REFERENCE DESIGNATIONS WITHIN THIS ASSEMBLY ARE ABBREVIATED. ADD ASSEMBLY NUMBER TO ABBREVIATION FOR COMPLETE DESCRIPTION.
 2. UNLESS OTHERWISE INDICATED: RESISTANCE IN OHMS CAPACITANCE IN FARADS INDUCTANCE IN HENRIES
 3. ASTERISK (*) INDICATES SELECTED COMPONENT, AVERAGE VALUES SHOWN.

Figure 8-29 A15 HP-IB Interface Assembly

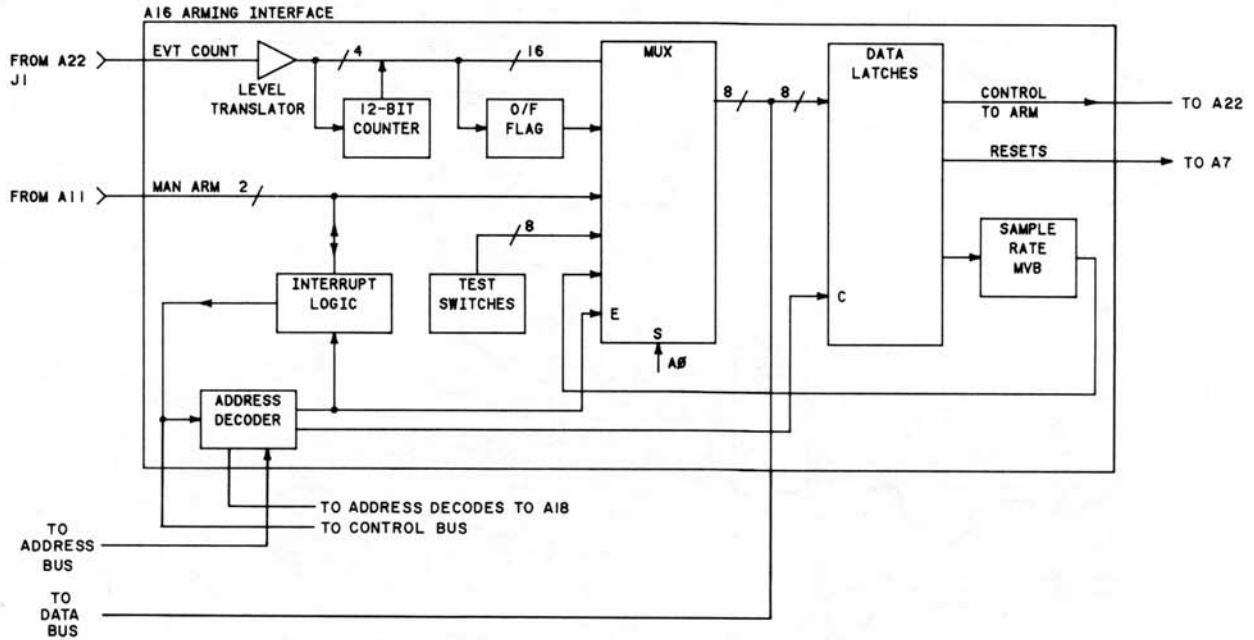

A16 ARMING INTERFACE ASSEMBLY

The Arming Interface Assembly (A16) contains the Address Decoder, Input/Output Registers, and Selector/Multiplexers needed for control interface between the Arming Assembly (A22), DAC/NØ Assembly (A18), and the Processor Assembly (A9).

Part of Figure 8-30. A16 Arming Interface Assembly

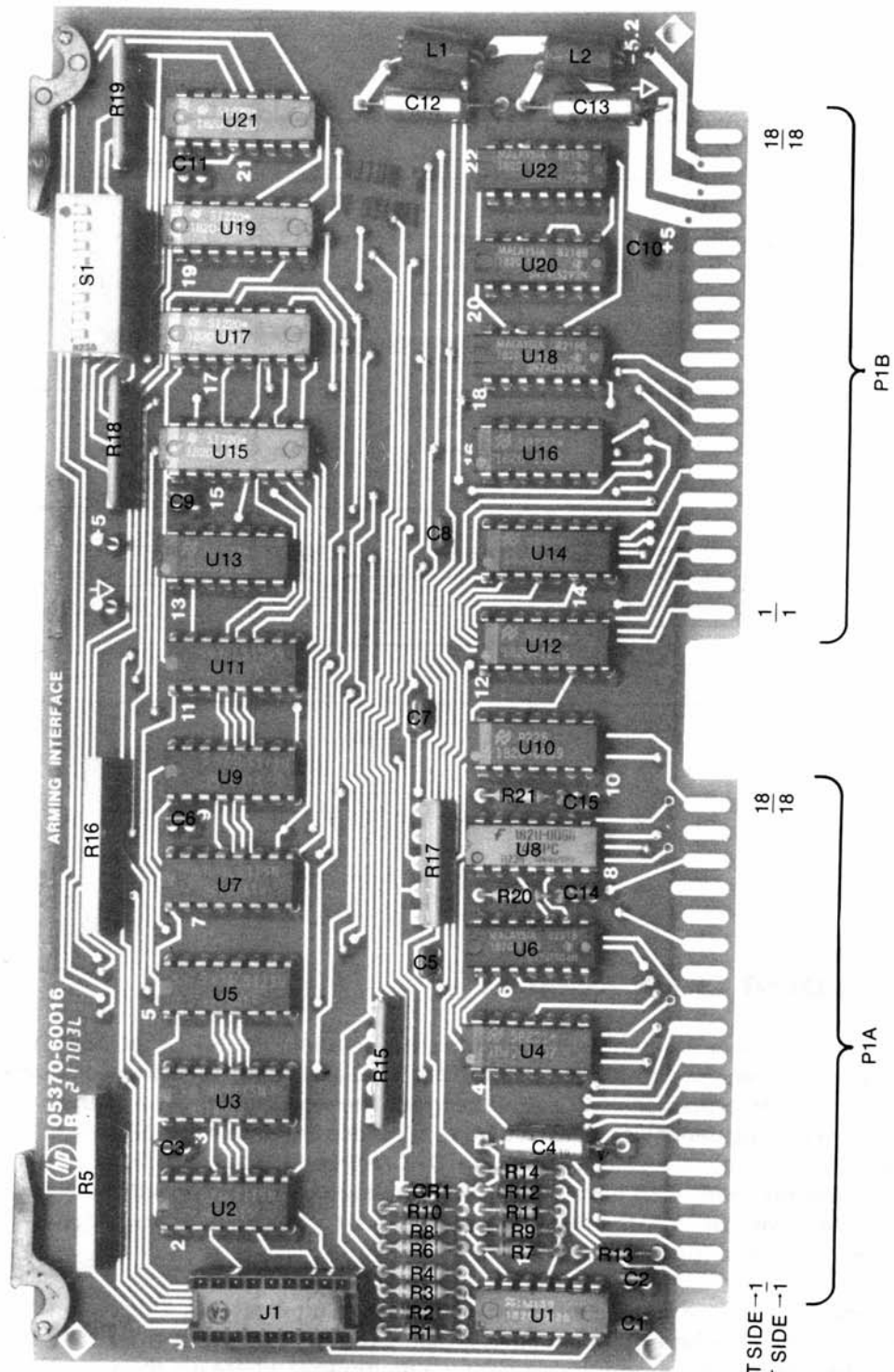

A16

First part of page 8-99, which folds out.

A16 ARMING INTERFACE (05370-60016) Series 2732

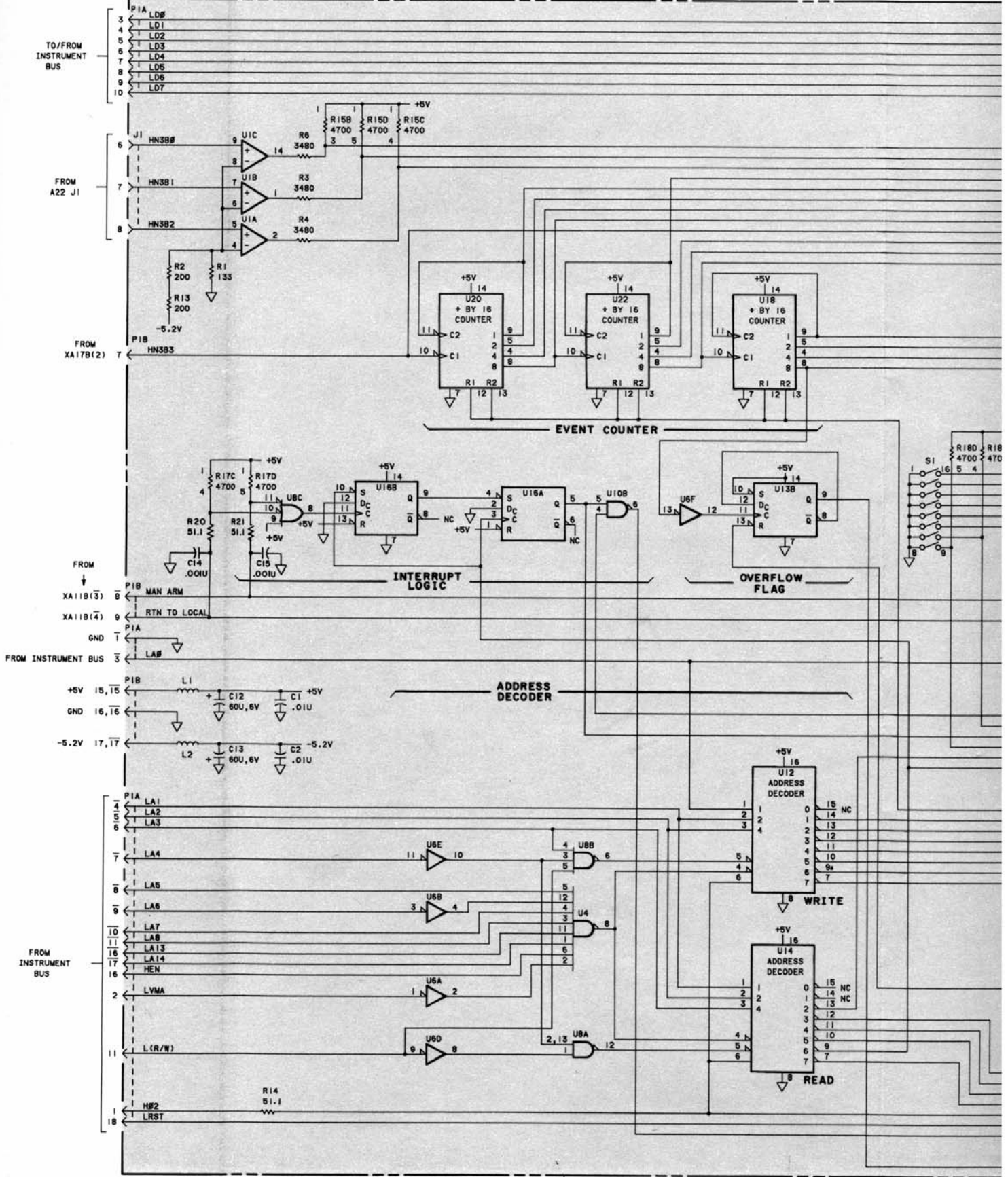

Second part of page 8-99, which folds out.

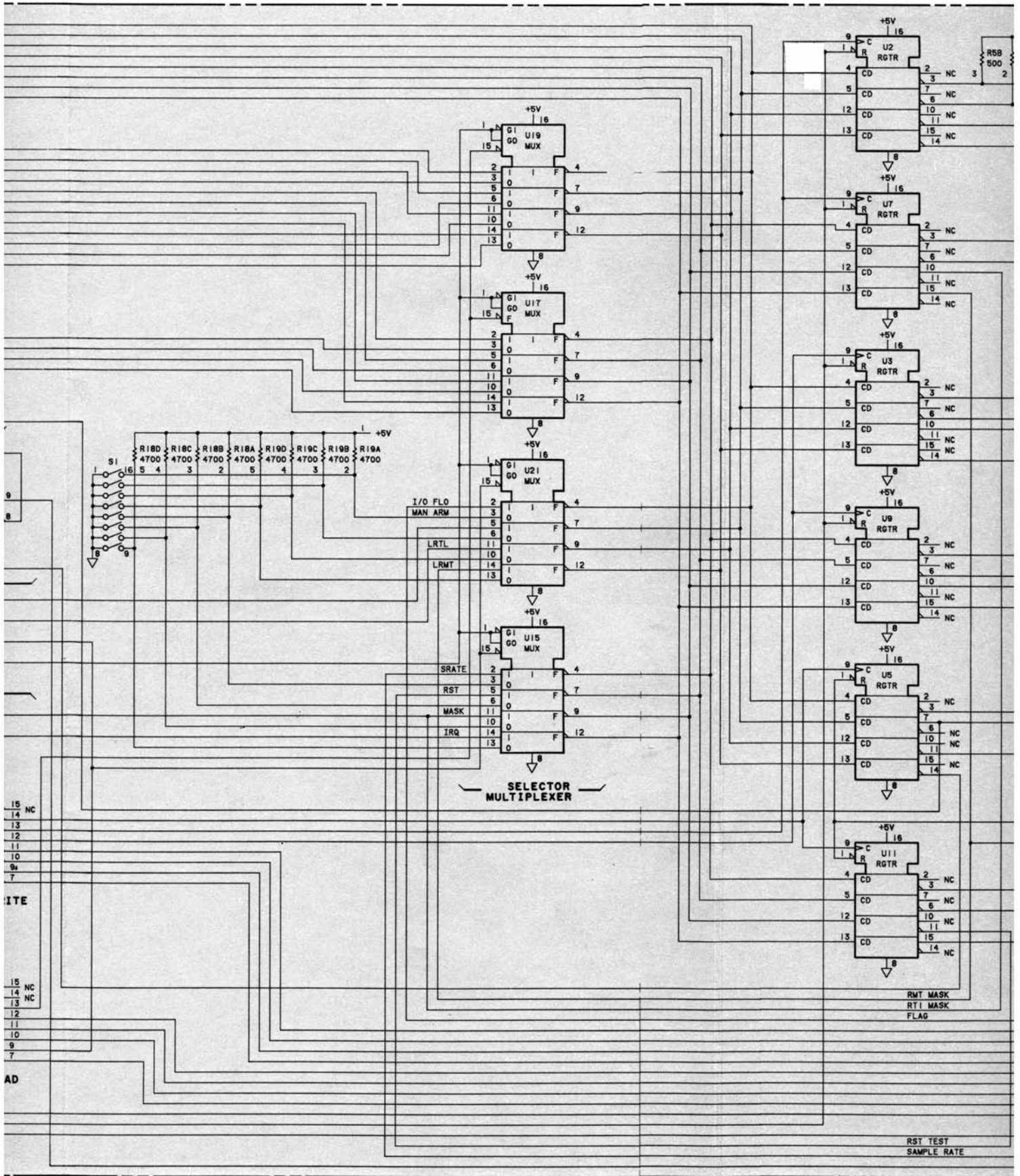

Third part of page 8-99, which folds out.

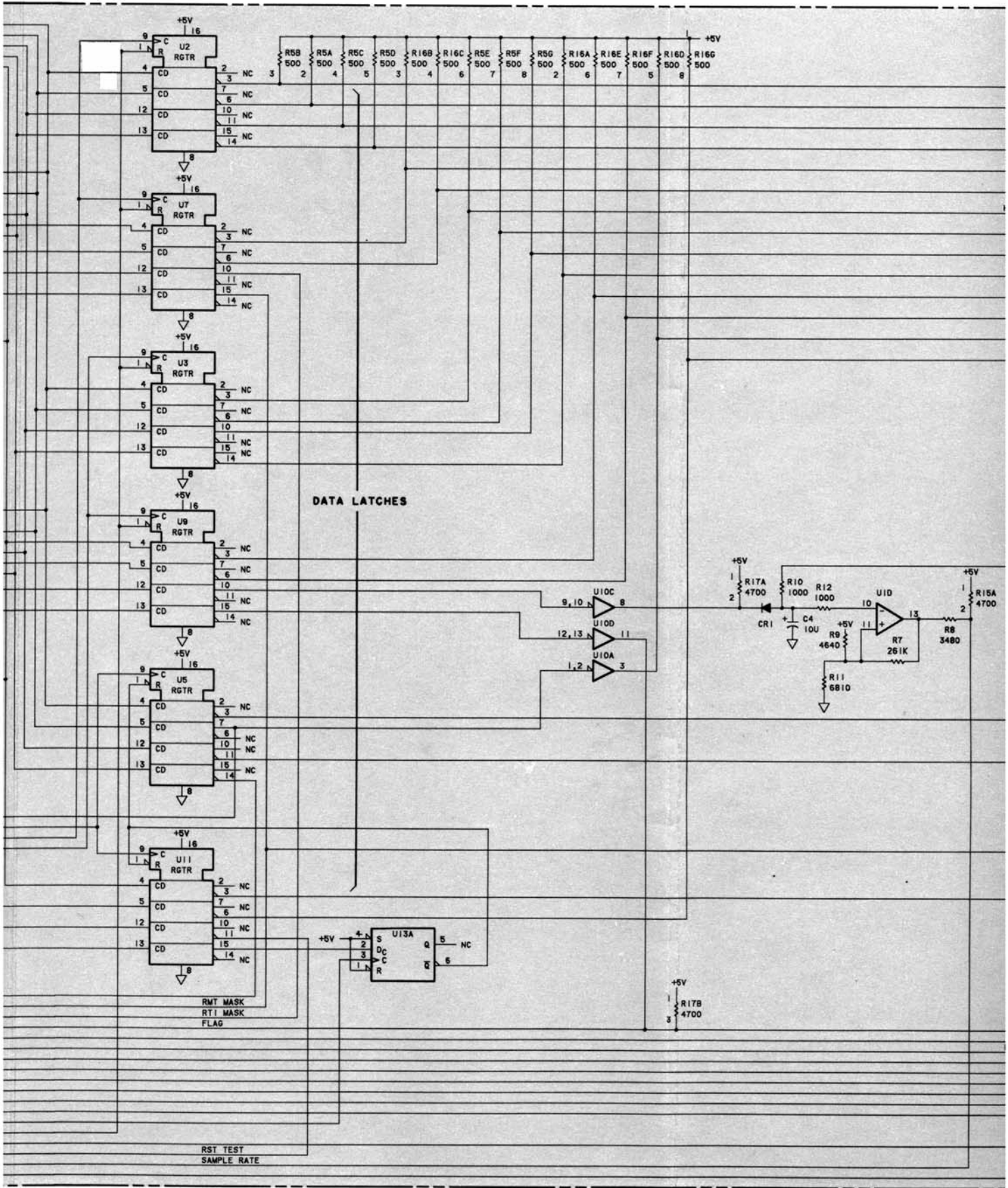

Fourth part of page 8-99, which folds out.

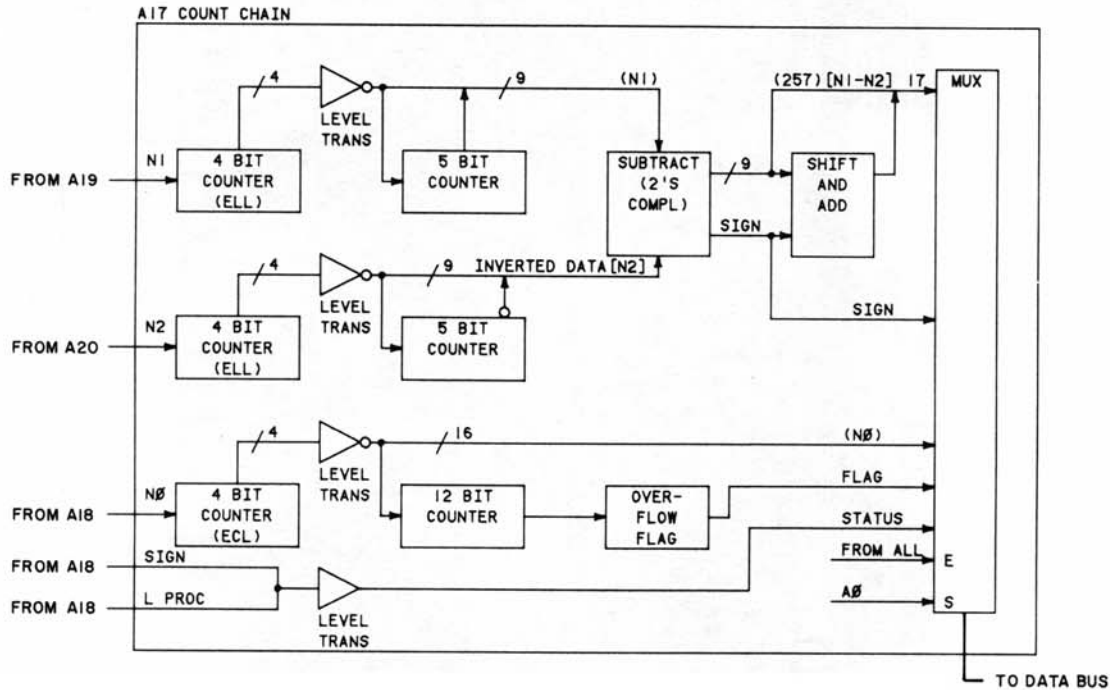

A17 COUNT CHAIN ASSEMBLY

The Count Chain Assembly (A17) accumulates (counts) the N1 signal (Start Interpolator VCO output between the start input pulse and the VCO and 200 MHz reference coincidence), the N2 count (Stop Interpolator VCO output between the stop input pulse and the VCO and 200 MHz reference coincidence), and N0 (200 MHz reference burst between N1 and N2). Other inputs to the A17 Assembly are LPROC from the DAC/N0 Logic Assembly (A18) which indicates both Interpolators (A19, A20) have completed a measurement cycle; and the Sign input also from the DAC/N0 Logic Assembly, indicating a start coincidence first (sign is High) or stop coincidence first (sign is Low).

N1 and N2 counts enter a subtractor where the result is $N1-N2$. This count then enters a shift and add block where it is effectively multiplied by 257 giving the result $257 \cdot (N1-N2)$. This number along with N0 and the sign enter a multiplexer where it is then output to the processor (A9) via the data bus.

Part of Figure 8-31. A17 Count Chain Assembly

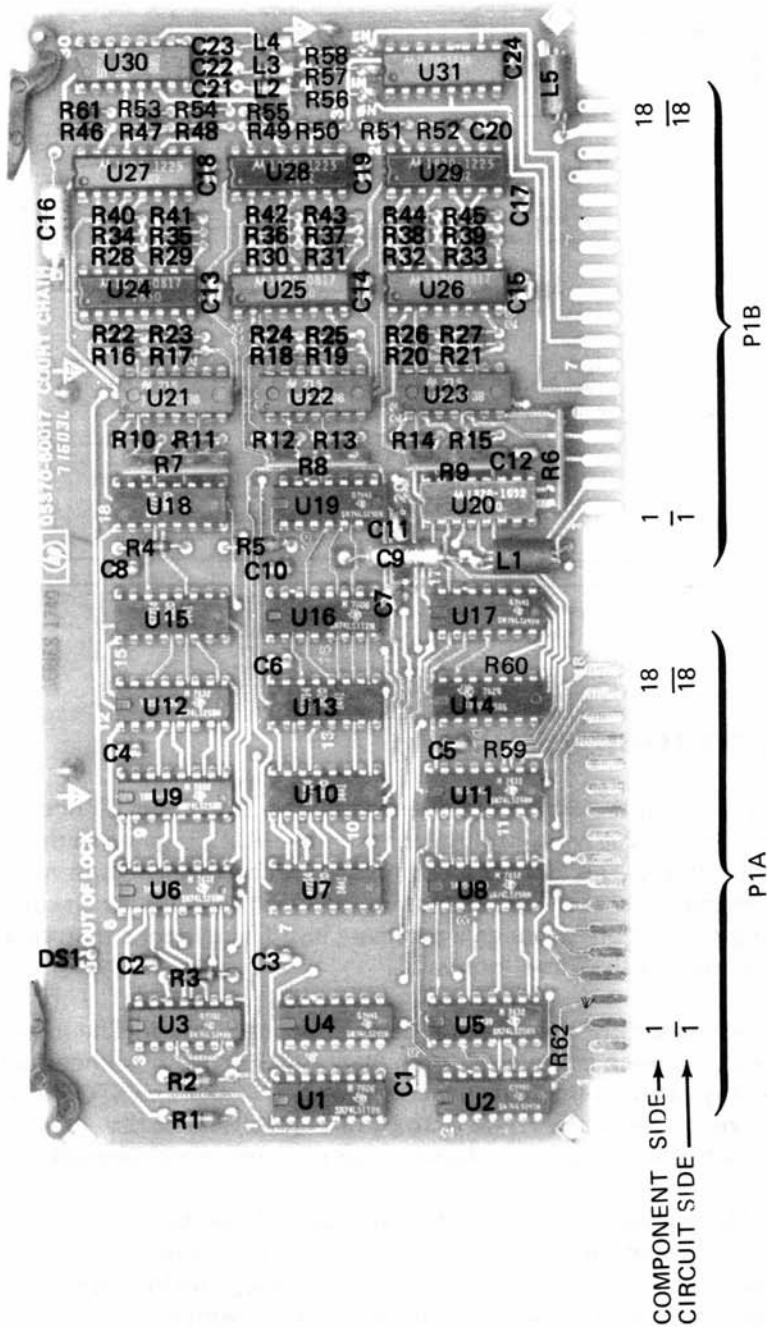

A17

First part of page 8-101, which folds out.

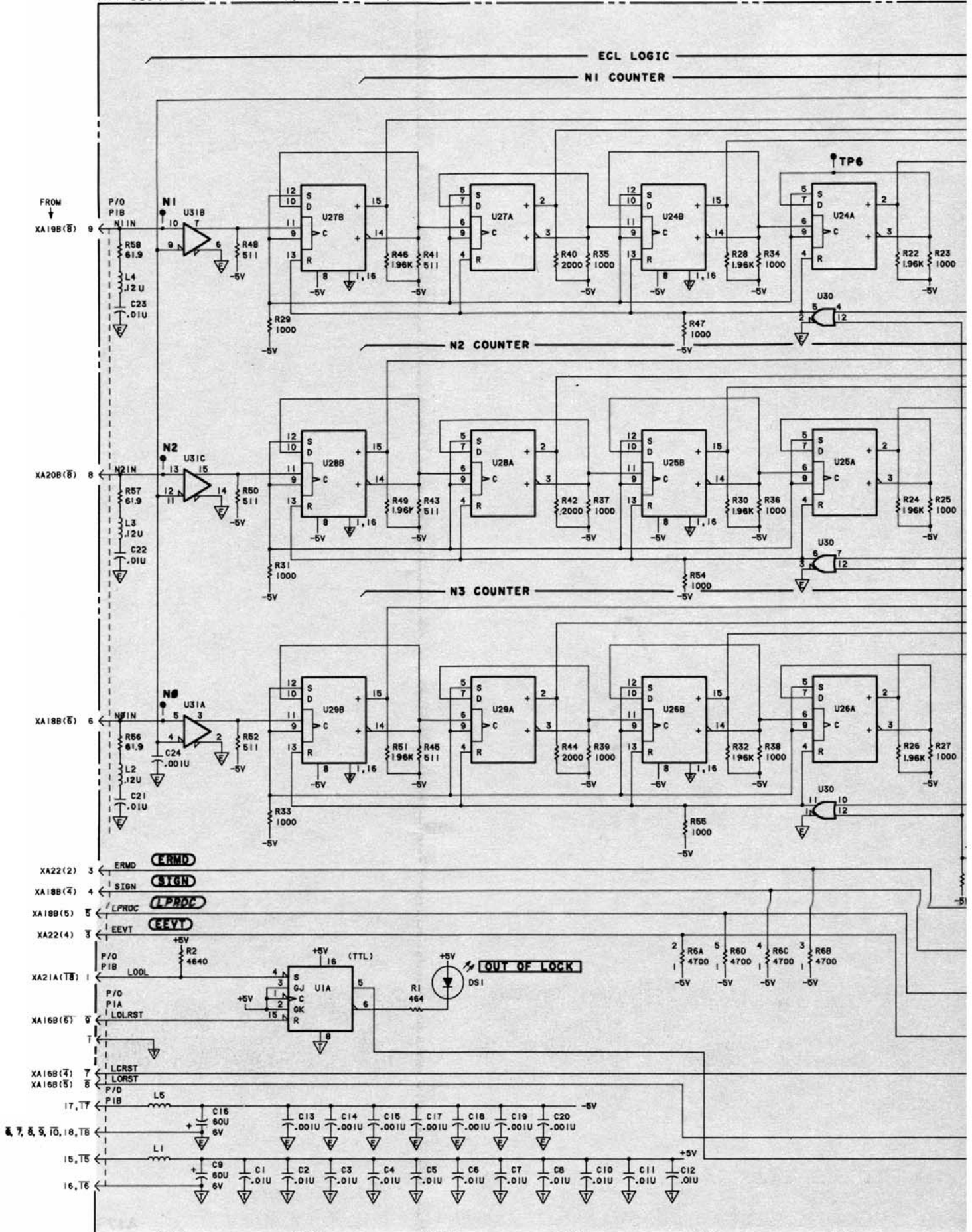

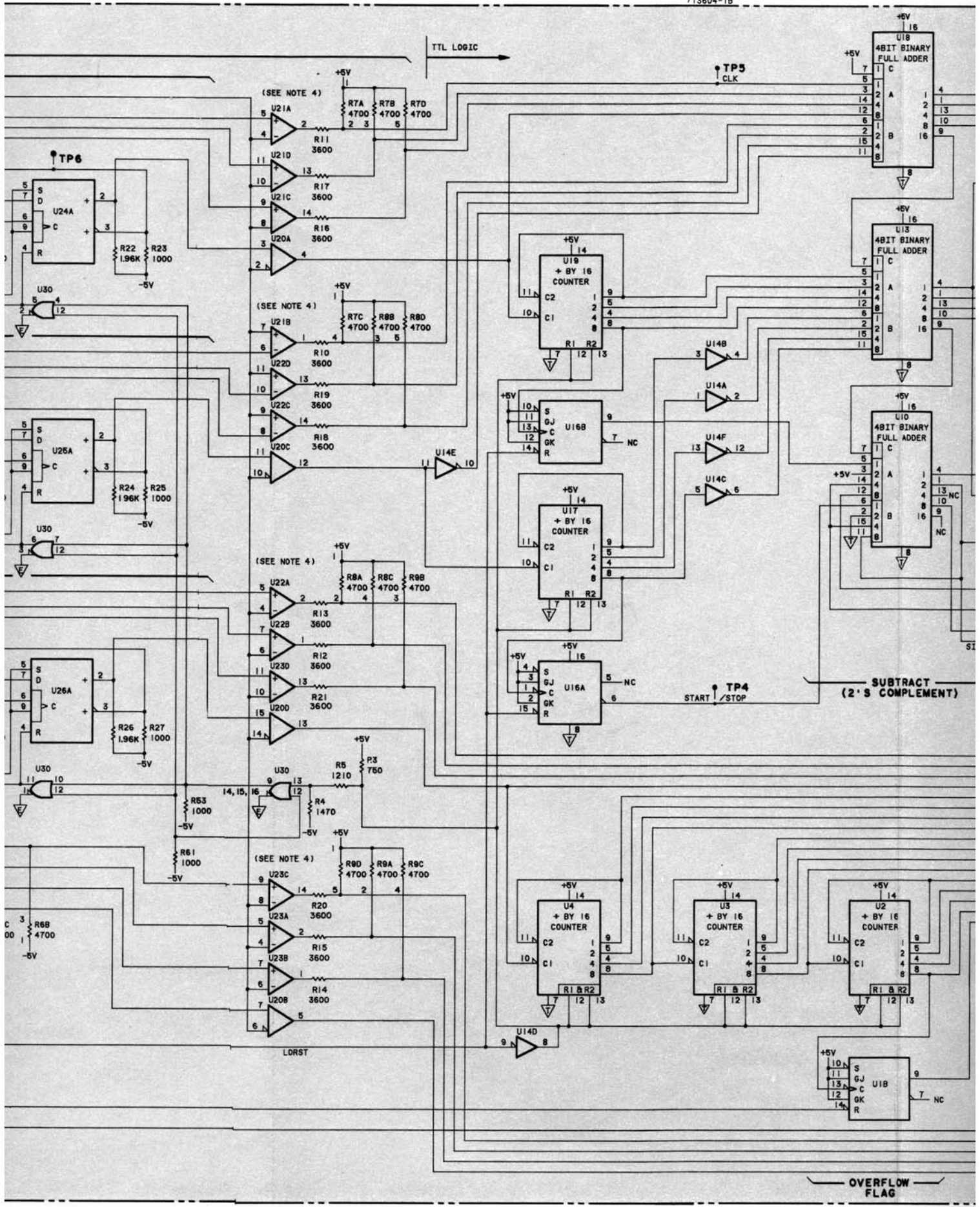

Third part of page 8-101, which folds out.

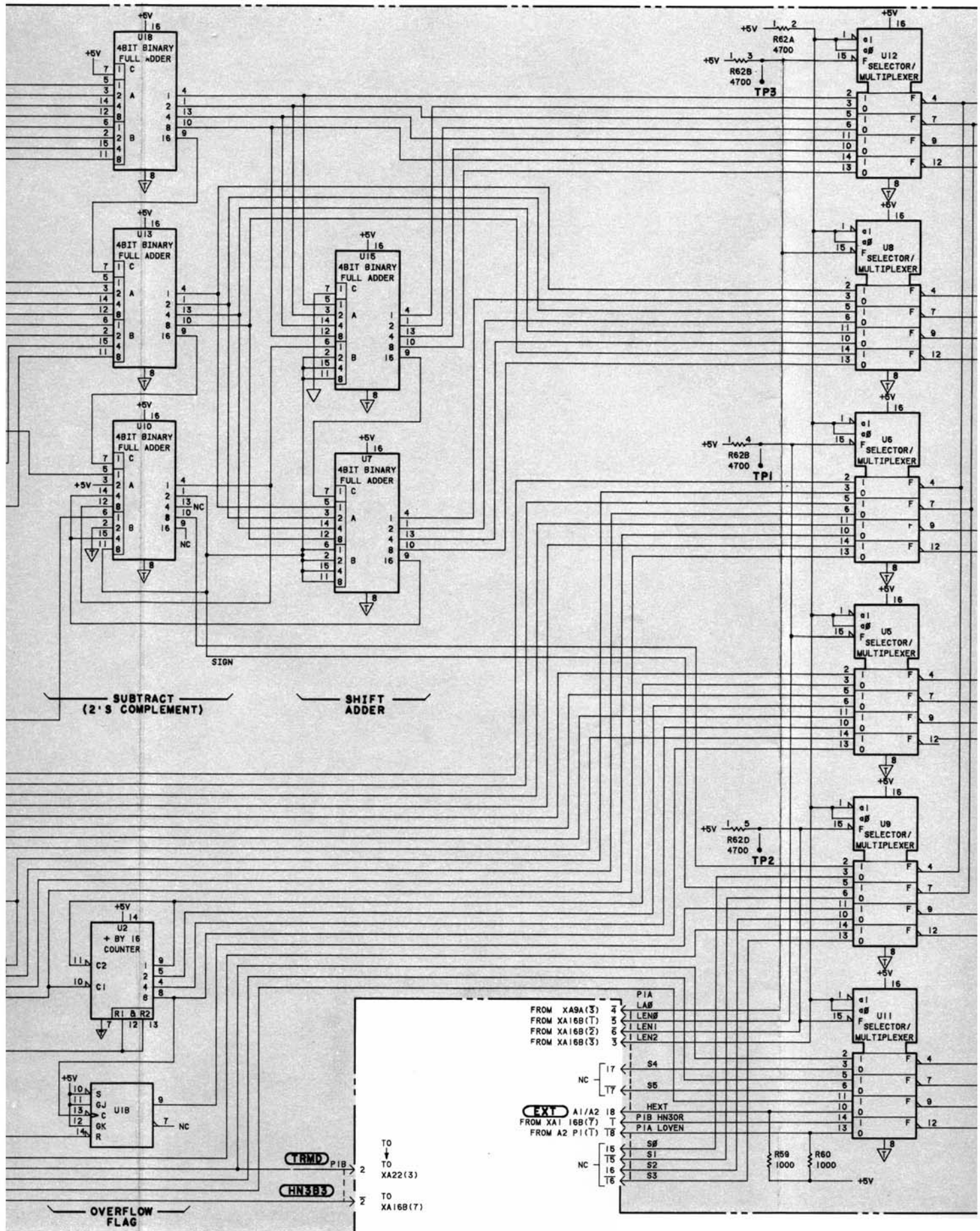

Fourth part of page 8-101, which folds out.

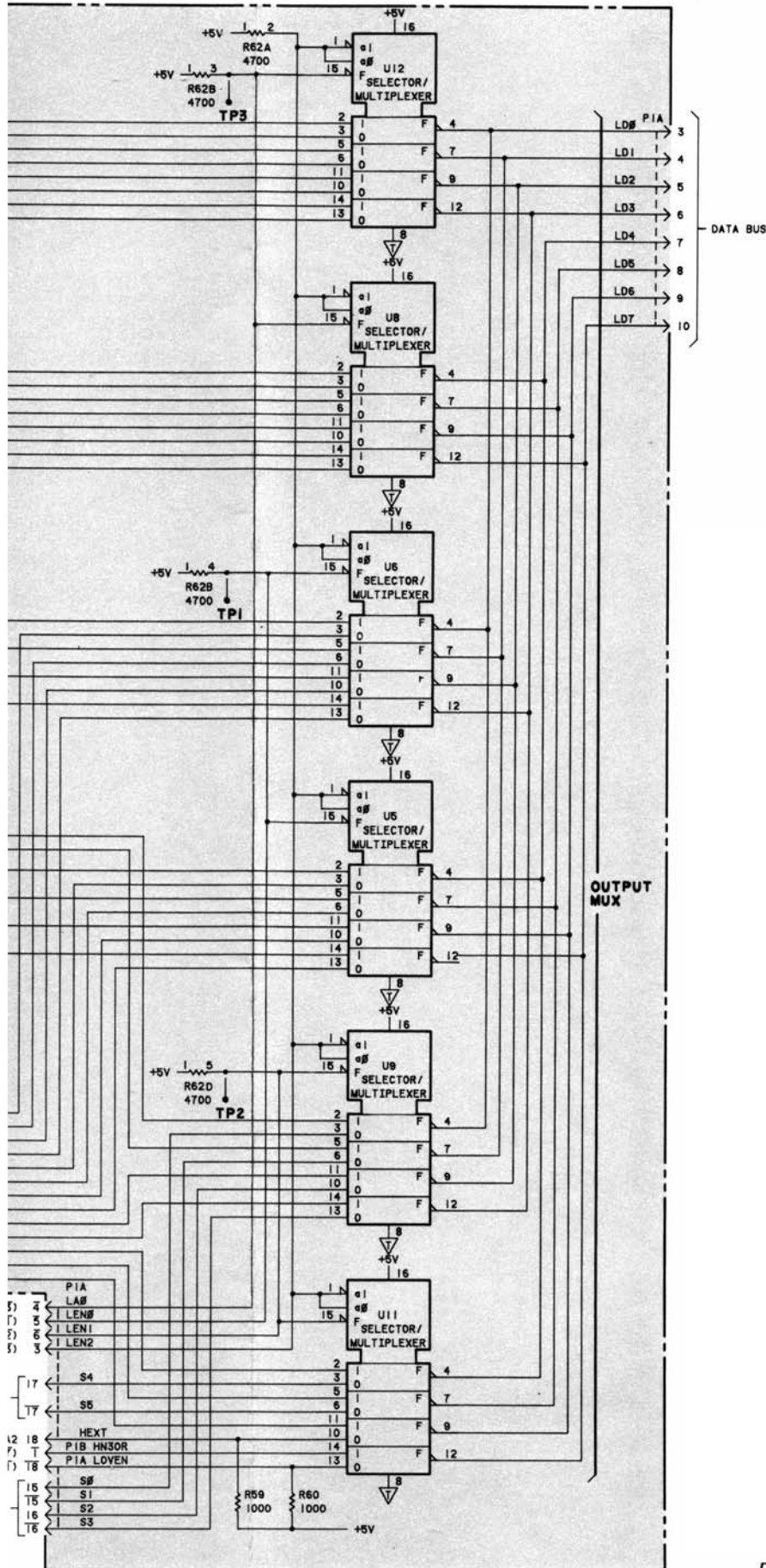

NOTES:

1. REFERENCE DESIGNATIONS WITHIN THIS ASSEMBLY ARE ABBREVIATED. ADD ASSEMBLY NUMBER TO ABBREVIATION FOR COMPLETE DESCRIPTION.
2. UNLESS OTHERWISE INDICATED: RESISTANCE IN OHMS. CAPACITANCE IN FARADS. INDUCTANCE IN HENRIES.
3. ASTERISK (*) INDICATES SELECTED COMPONENT, AVERAGE VALUES SHOWN.
4. ON U21, U22 AND U23 VCC IS +5V AND IS CONNECTED TO PIN 3 AND GROUND IS -5V AND IS CONNECTED TO PIN 12.

Figure 8-31. A17 Count Chain Assembly

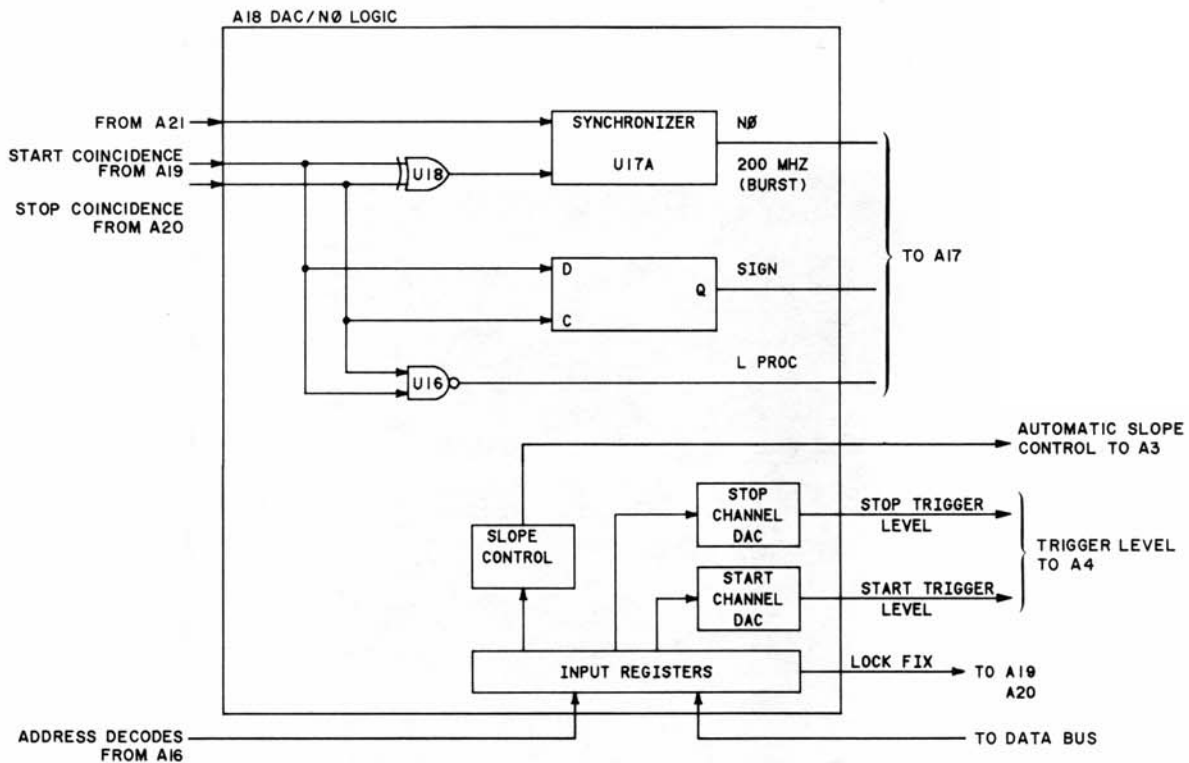

A18 DAC/NØ LOGIC ASSEMBLY

Between the time of the Start Coincidence and the Stop Coincidence, the 200 MHz reference frequency, from the 200 MHz Multiplier Assembly (A21), is gated to the Count Chain Assembly by the A18 Assembly. This 200 MHz burst is sent to the Count Chain Assembly as the NØ count. The DAC/NØ Logic Assembly also keeps track of which coincidence occurred first. This allows the DAC/NØ Logic Assembly to assign a positive (Start Coincidence first) or a negative (Stop Coincidence first) sign to the Time Interval.

The DAC/NØ Assembly tells the processor, via the Count Chain board (A17), when the measurement has been completed (both Start and Stop Coincidences occurred). The DAC/NØ Logic Assembly contains the logic which allows the START and STOP input LEVEL control to be program set remotely via the HP-IB or to be monitored and displayed in DC volts. It also contains the logic which allows the input slopes to be remotely programmed.

The Lock Fix output from the DAC/NØ Logic Assembly to the Interpolator Assemblies (A19, A20) is active on power-up. When active, it gives the phase detectors on the Interpolators an indication that the VCO frequency is high. As a result, the VCO frequency is pulled low. When Lock Fix goes inactive, it releases the phase detectors which then lock the VCOs to the correct frequency. This is performed to insure that the VCOs lock to the correct sideband of the 200 MHz reference when the instrument is first turned on.

Part of Figure 8-32. A18 DAC/NØ Logic Assembly

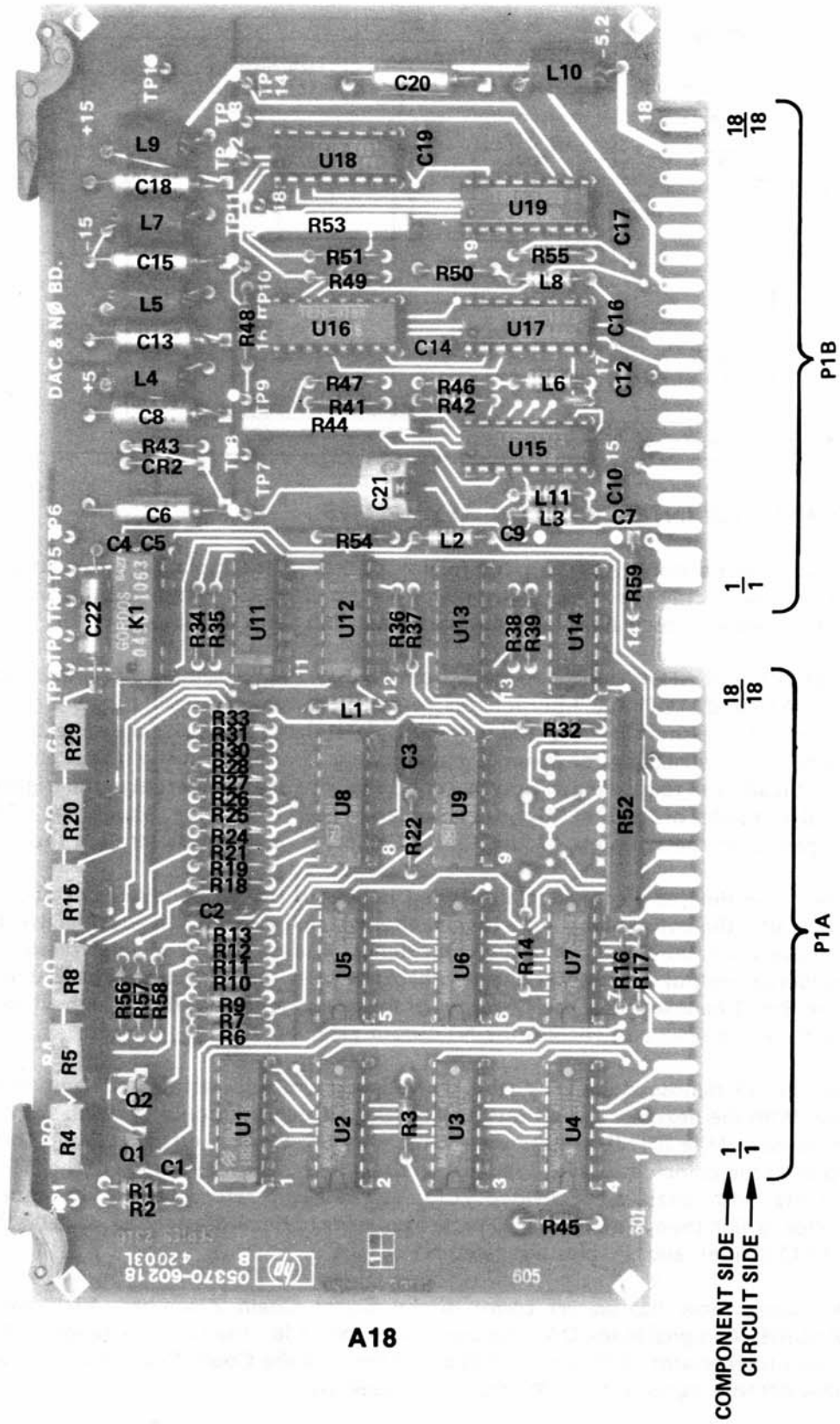

First part of page 8-103, which folds out.

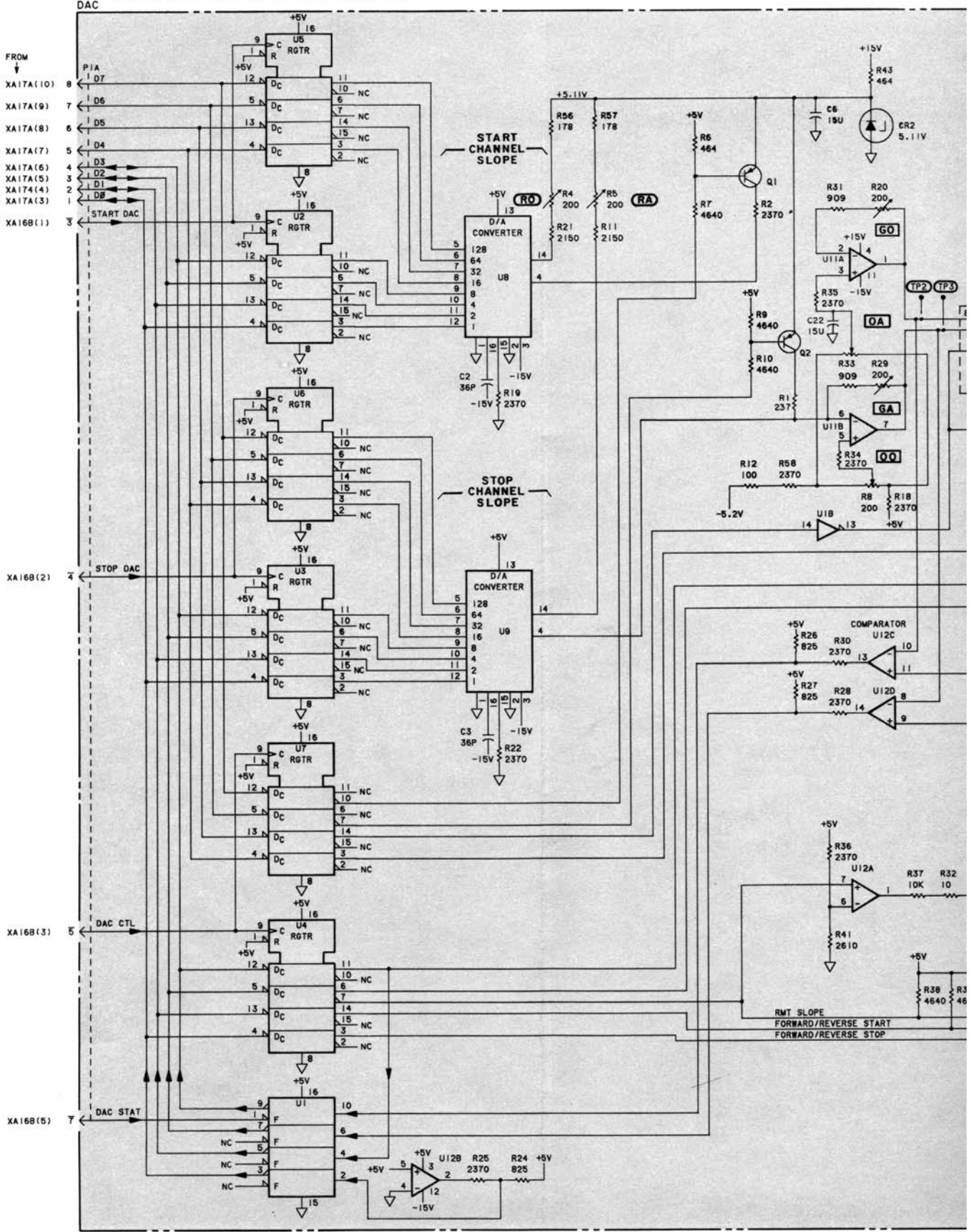

Second part of page 8-103, which folds out.

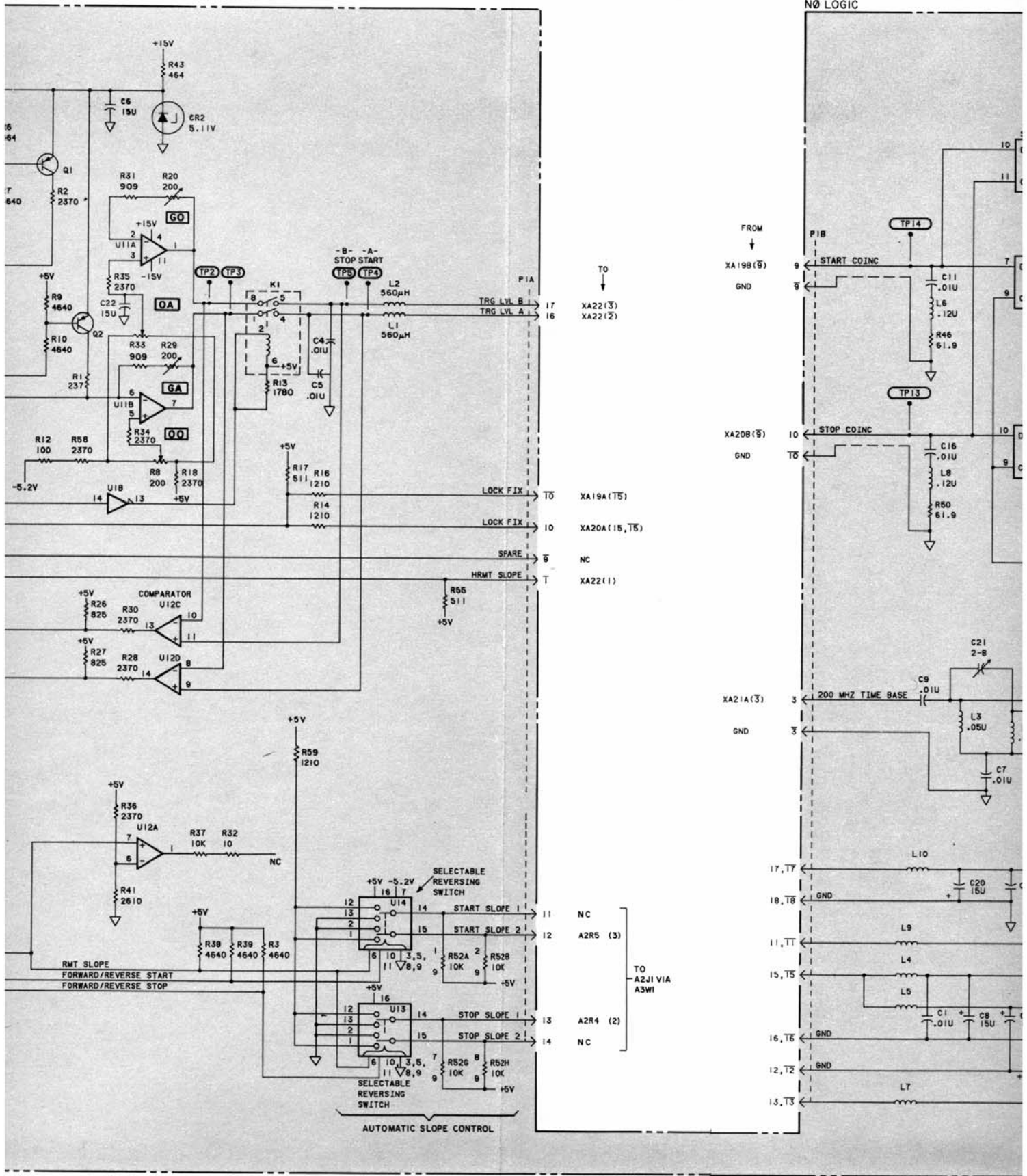

Third part of page 8-103, which folds out.

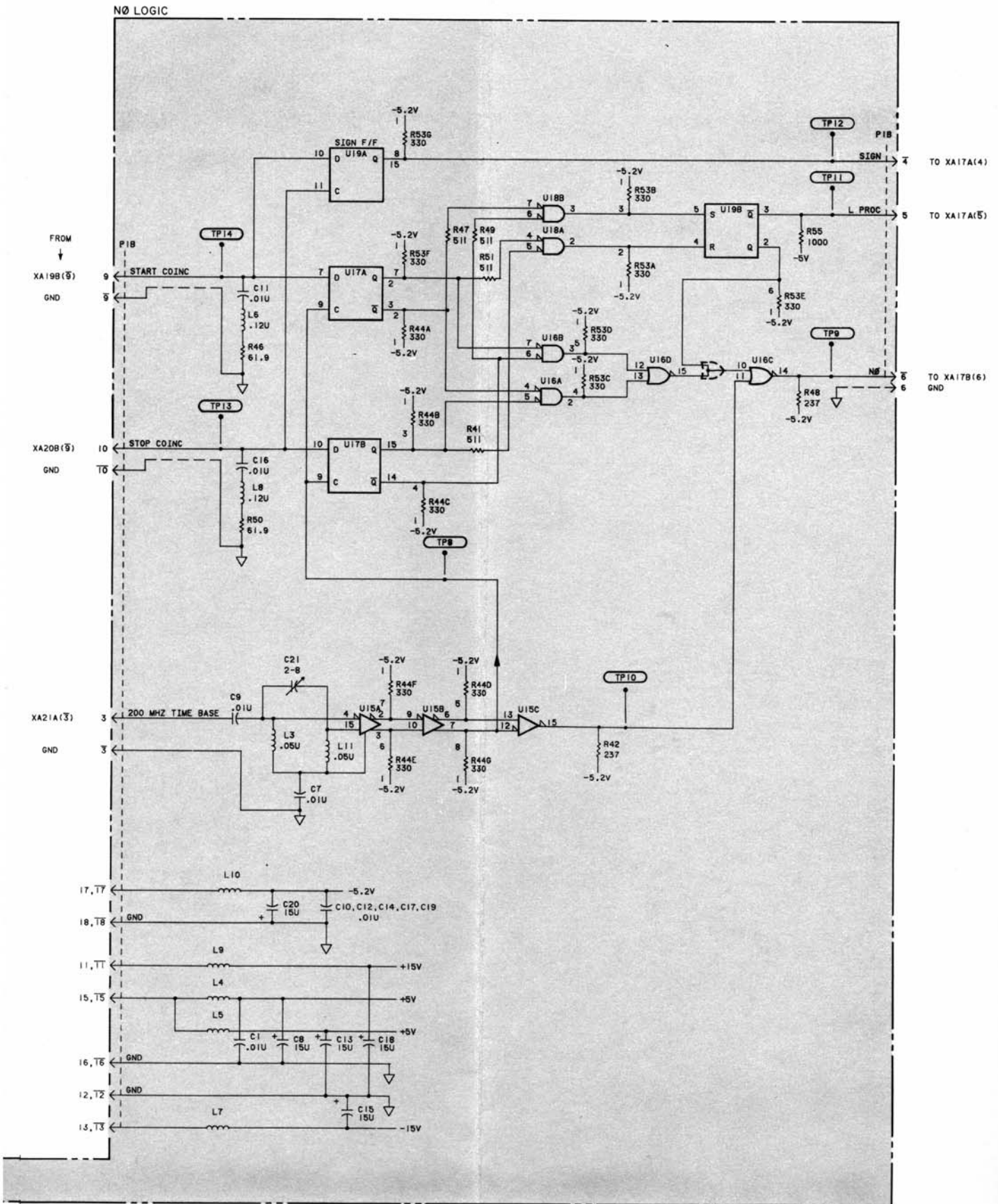

Fourth part of page 8-103, which folds out.

Figure 8-32. A18

NOTES

1. REFERENCE DESIGNATIONS WITHIN THIS ASSEMBLY ARE ABBREVIATED. ADD ASSEMBLY NUMBER TO ABBREVIATION FOR COMPLETE DESCRIPTION.
2. UNLESS OTHERWISE INDICATED: RESISTANCE IN OHMS
CAPACITANCE IN FARADS
INDUCTANCE IN HENRIES
3. ASTERISK (*) INDICATES SELECTED COMPONENT, AVERAGE VALUES SHOWN.

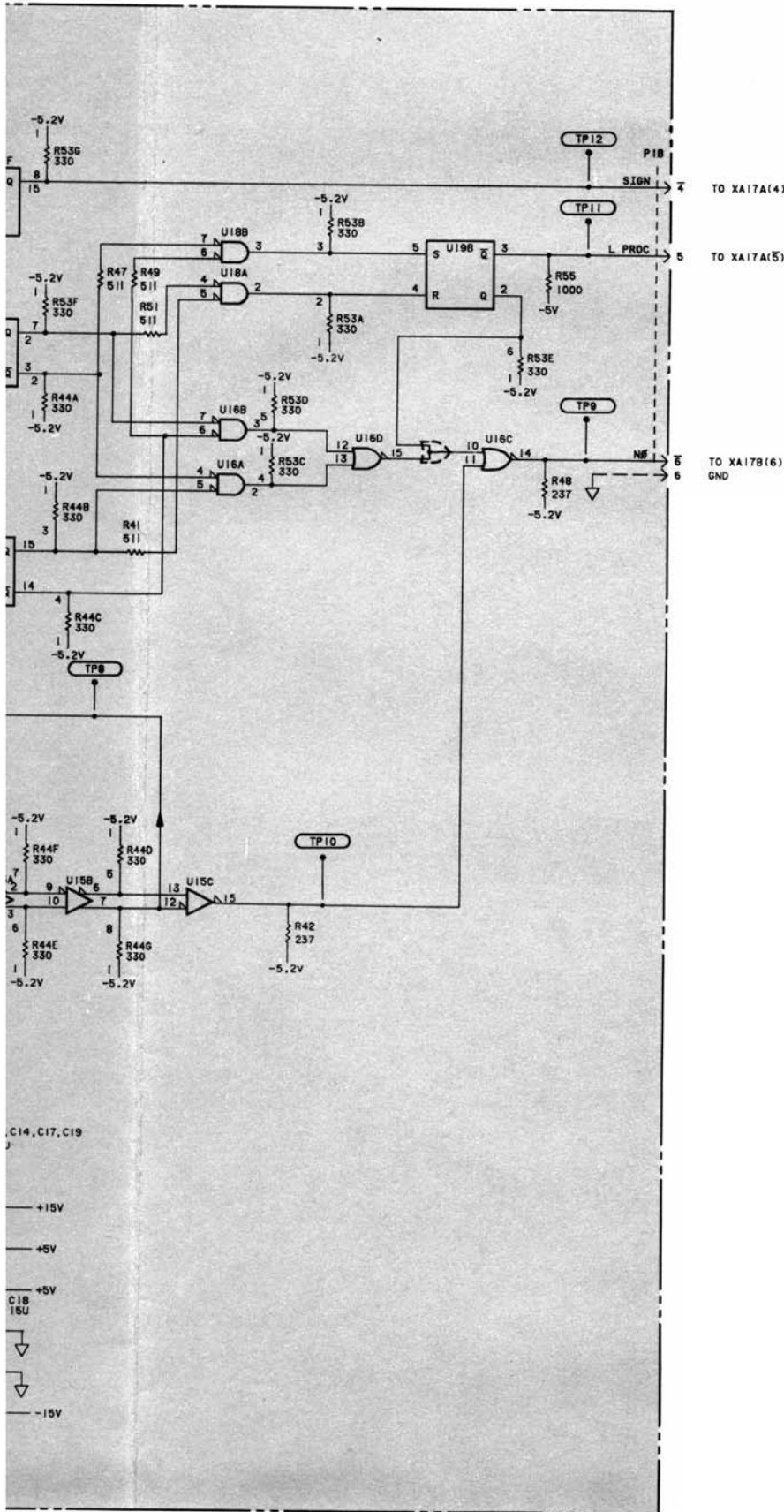
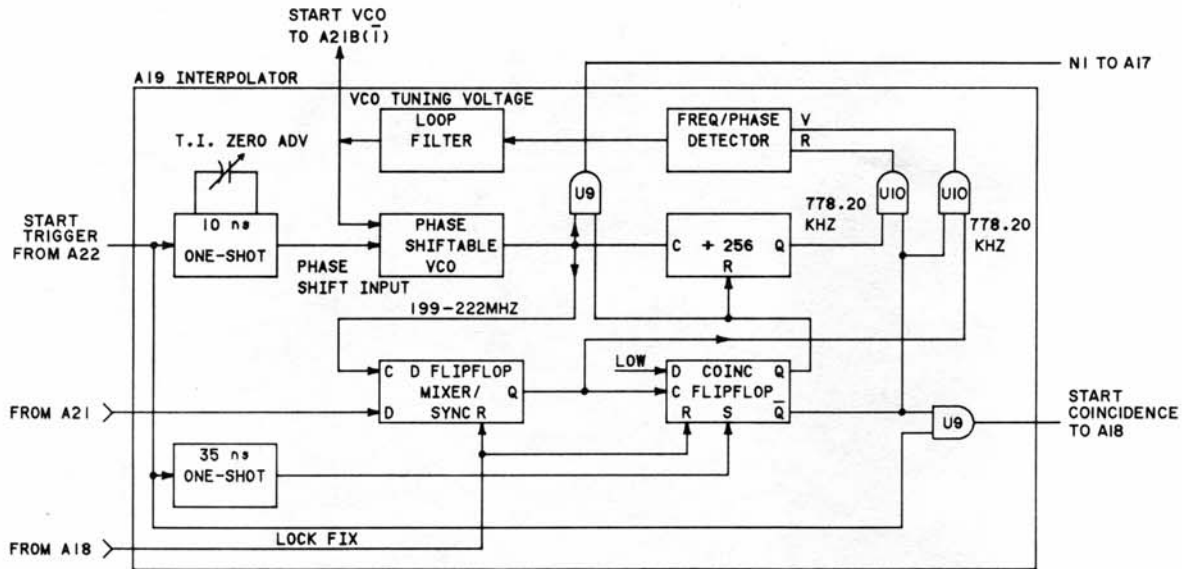

Figure 8-32. A18 DAC/NO Logic Assembly

Fifth (and final) part of page 8-103, which folds out.



A19 AND A20 INTERPOLATOR ASSEMBLIES

The two interpolators (A19 Start Interpolator, A20 Stop Interpolator) are exactly the same. For this reason, only the START Interpolator will be discussed. The Interpolators are basically phase changeable, oscillation interruptible, phase-locked-loop oscillators.

The START and STOP output triggers from the Arming Assembly (A22) are input to the START (A19) and STOP (A20) Interpolators, respectively. When an input trigger arrives, it goes to two delayed one-shot flip-flops and to the enable of the coincidence output gate. The VCO is inhibited from oscillating for about 10 nanoseconds after the arrival of the input trigger after which it is allowed to oscillate in a normal condition, but phase coherent to the trigger, and at its normal frequency of 199.2218 MHz, as controlled by the VCO tuning voltage. The VCO output is then passed to the counters on the Count Chain Assembly (A17) through the output gate.

At the same time, the coincidence flip-flop is held in the set condition for about 35 nanoseconds after the arrival of the input trigger, after which the set enable goes inactive. During this 35 nanoseconds, the Q output of the coincidence flip-flop goes low which disables the gated coincidence output and breaks the feedback loop to the Frequency-Phase detector. Also during the 35 nanoseconds, the Q output of the coincidence flip-flop is high which holds the ÷256 divider in reset and enables the N1 output gate.

After the 35 nanosecond delay, the coincidence flip-flop is released from the set condition. With the next low to high output from the Mixer/Synchronizer, which signifies a phase coincidence of the 200 MHz reference and the VCO, a low is clocked to the Q and a high to the Q outputs of the coincidence flip-flop. This sends a phase coincident signal to the DAC/N0 Logic Assembly (A18), enables the divided VCO and the Mixer reference to the Frequency/Phase detector, which then allows the VCO to be frequency corrected if needed, releases the reset on the VCO divider, and disables the gated N1 output.

The counter now has an N1 count in the Count Chain Assembly (A17), and a START COINCIDENCE signal in the DAC/N0 Logic Assembly (A18). The same operation is performed in the Stop Interpolator (A20) which gives an N2 count in the Count Chain Assembly and a STOP COINCIDENCE signal in the DAC/N0 Logic Assembly.

Part of Figure 8-33. A19 Start Interpolator Assembly, A20 Stop Interpolator Assembly

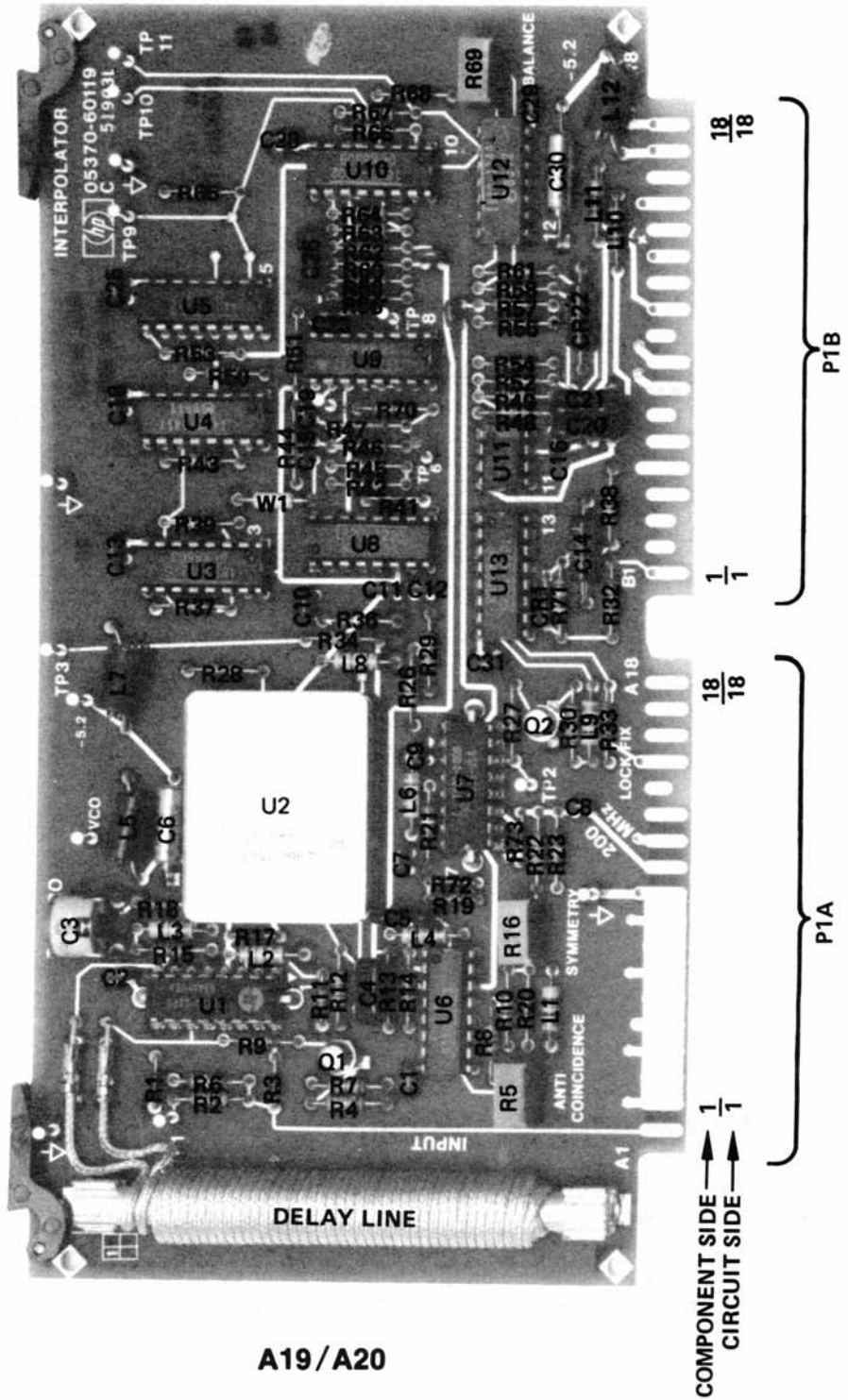

First part of page 8-105, which folds out.

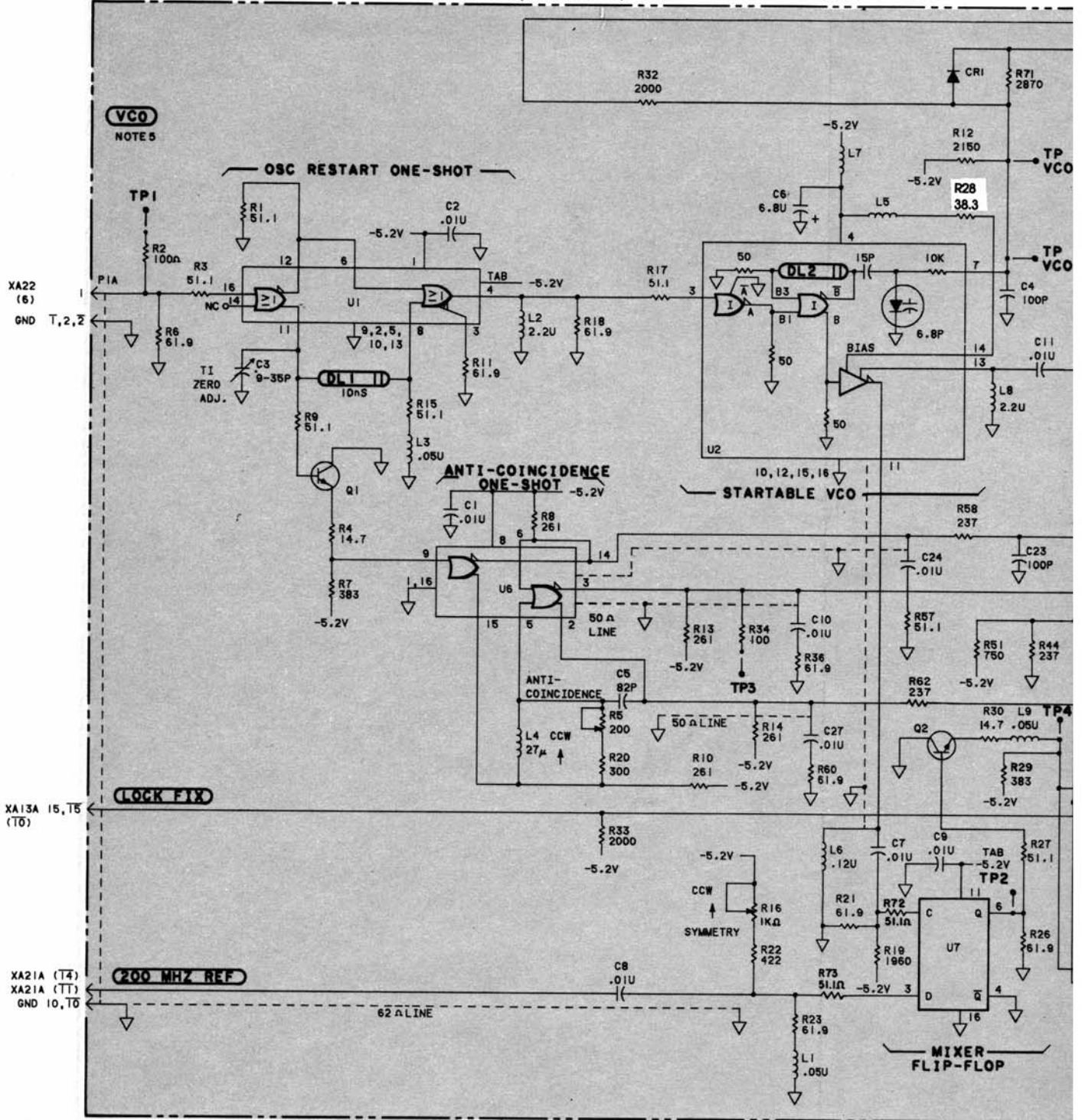

Second part of page 8-105, which folds out.

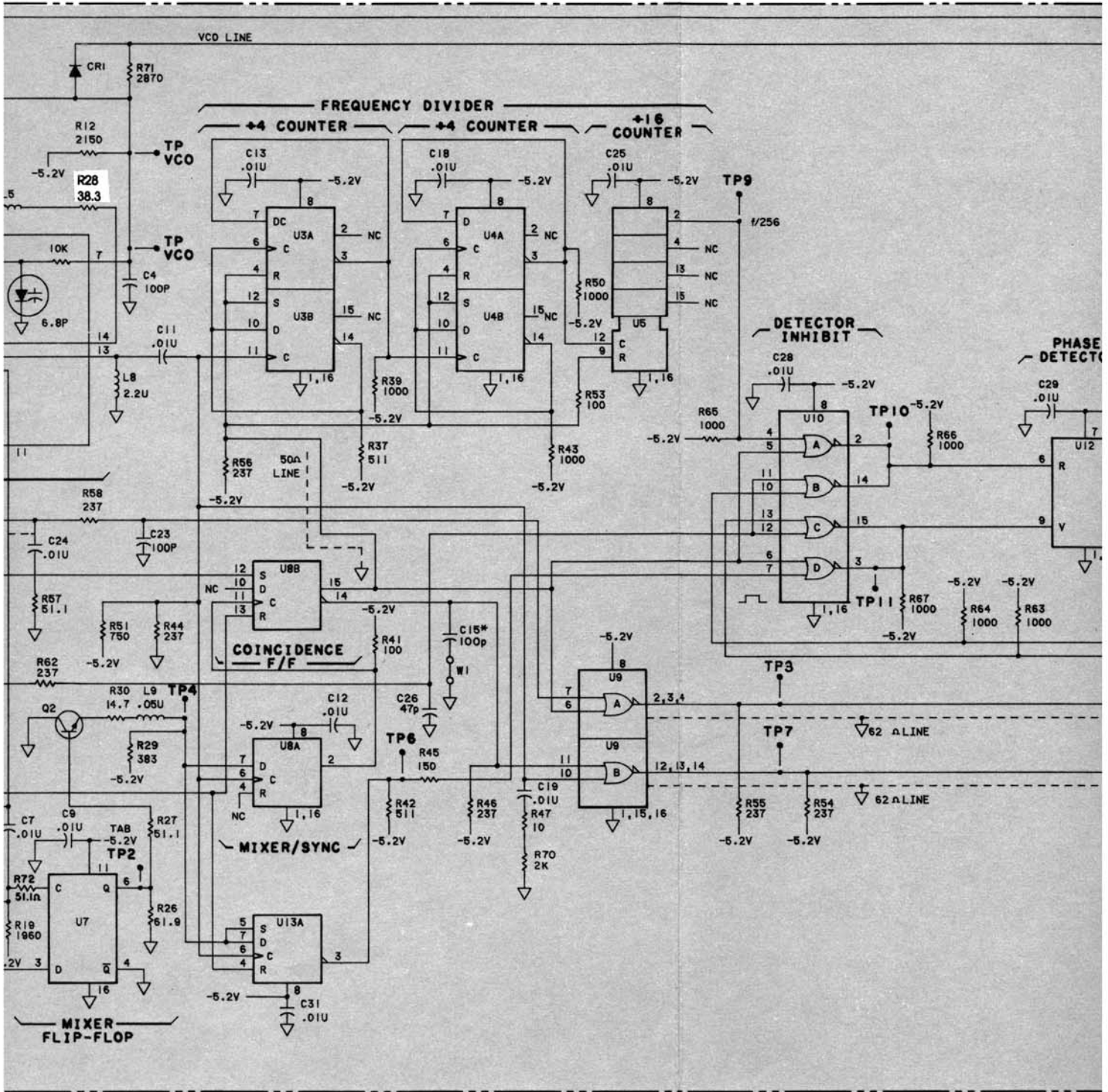

Third part of page 8-105, which folds out.

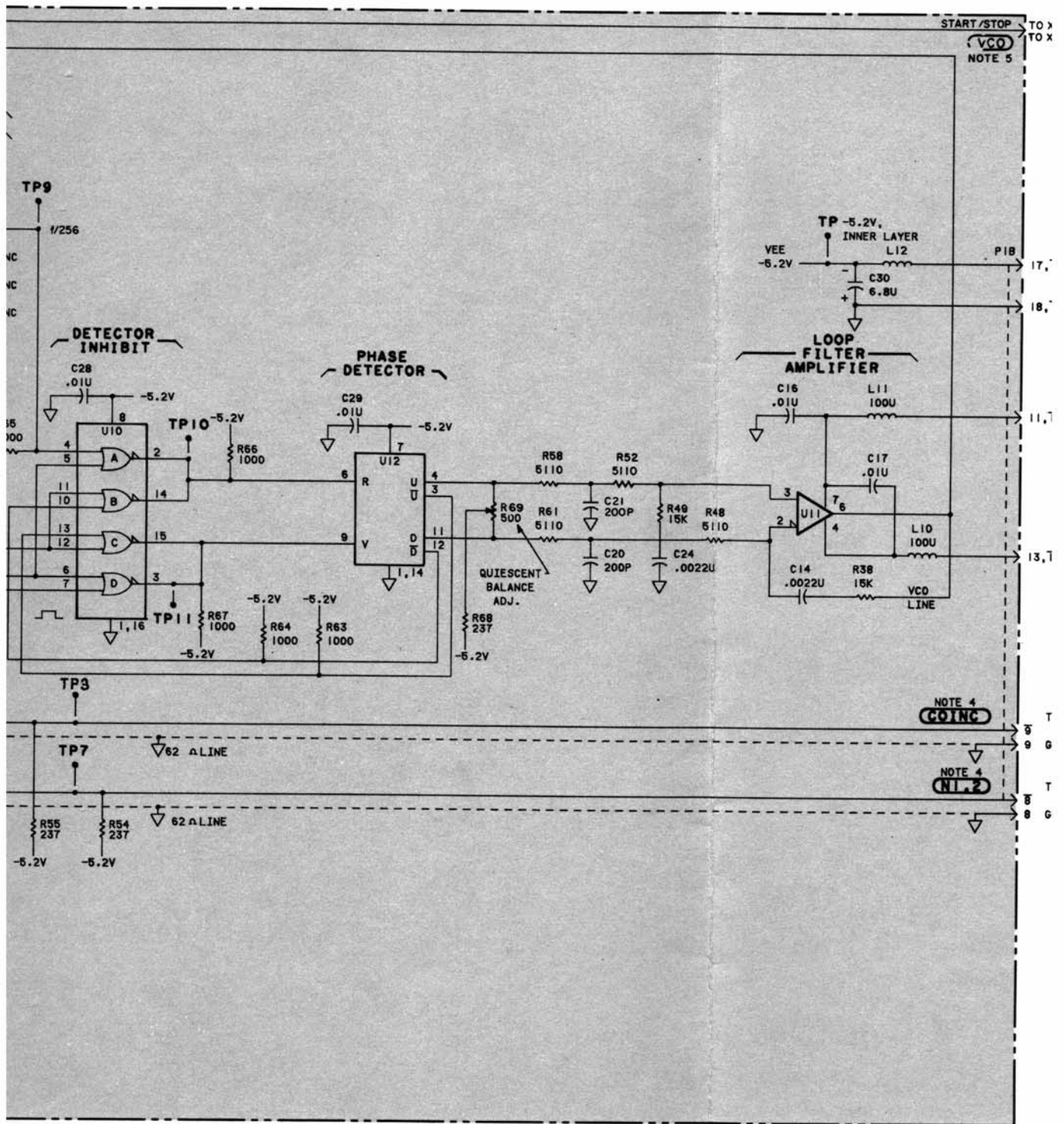

Fourth part of page 8-105, which folds out.

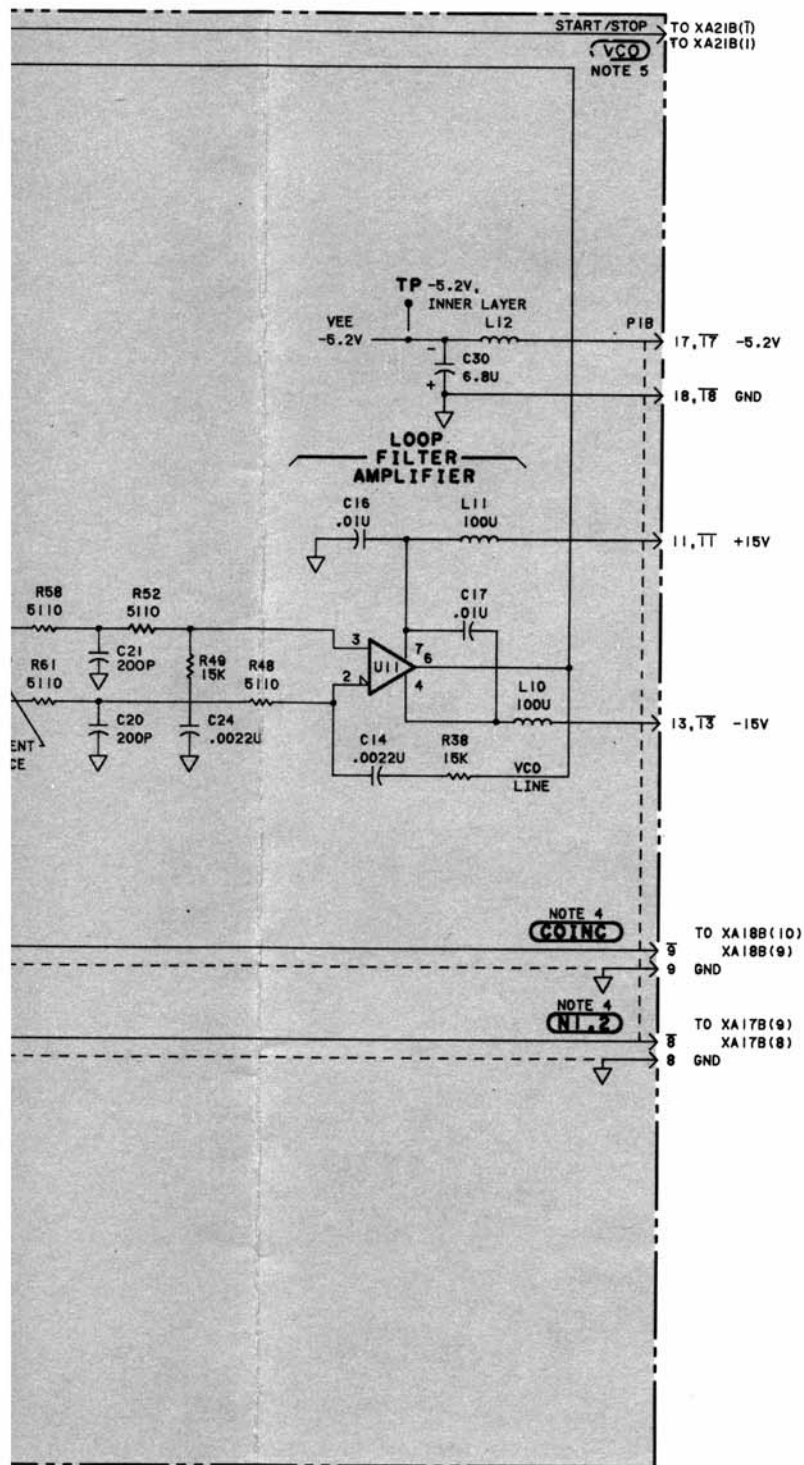

NOTES

1. REFERENCE DESIGNATIONS WITHIN THIS ASSEMBLY ARE ABBREVIATED. ADD ASSEMBLY NUMBER TO ABBREVIATION FOR COMPLETE DESCRIPTION.
2. UNLESS OTHERWISE INDICATED:
RESISTANCE IN OHMS
CAPACITANCE IN FARADS
INDUCTANCE IN HENRIES
3. ASTERISK (*) INDICATES SELECTED COMPONENT, AVERAGE VALUES SHOWN.
4. THE UPPER DESTINATIONS ARE TO THE A18 ASSEMBLY FROM THE A19 ASSEMBLY. THE LOWER DESTINATIONS ARE TO THE A18 ASSEMBLY FROM THE A20 ASSEMBLY.
5. THE UPPER DESTINATION IS TO A21 FROM A19. THE LOWER DESTINATION IS TO A21 FROM A20.

NOTE 4
GOING

NOTE 4
NL.2

Figure 8-33
A19 START INTERPOLATOR ASSEMBLY,
A20 STOP INTERPOLATOR ASSEMBLY
Fifth (and final) part of page 8-105, which folds out.
(See Page 8-105)

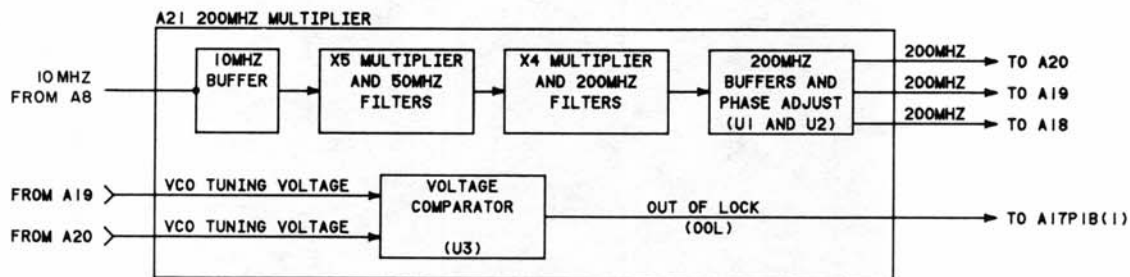

A21 200 MHz MULTIPLIER ASSEMBLY

The 200 MHz Multiplier Assembly (A21) multiplies the 10 MHz input to 200 MHz. This is accomplished by two cascaded multipliers (X5 and X4) and filter stages. The 200 MHz is then buffered, sent to the interpolators (A19, A20), and phase adjusted and sent to the DAC Assembly (A18). There is also a separate voltage comparator circuit which compares each VCO tuning voltage from the two interpolators with fixed reference voltages. When either VCO tuning voltage is outside designed limits, a signal is sent to the A17 Count Chain Assembly where it is latched as a status bit.

Part of Figure 8-34. A21 200 MHz Multiplier Assembly

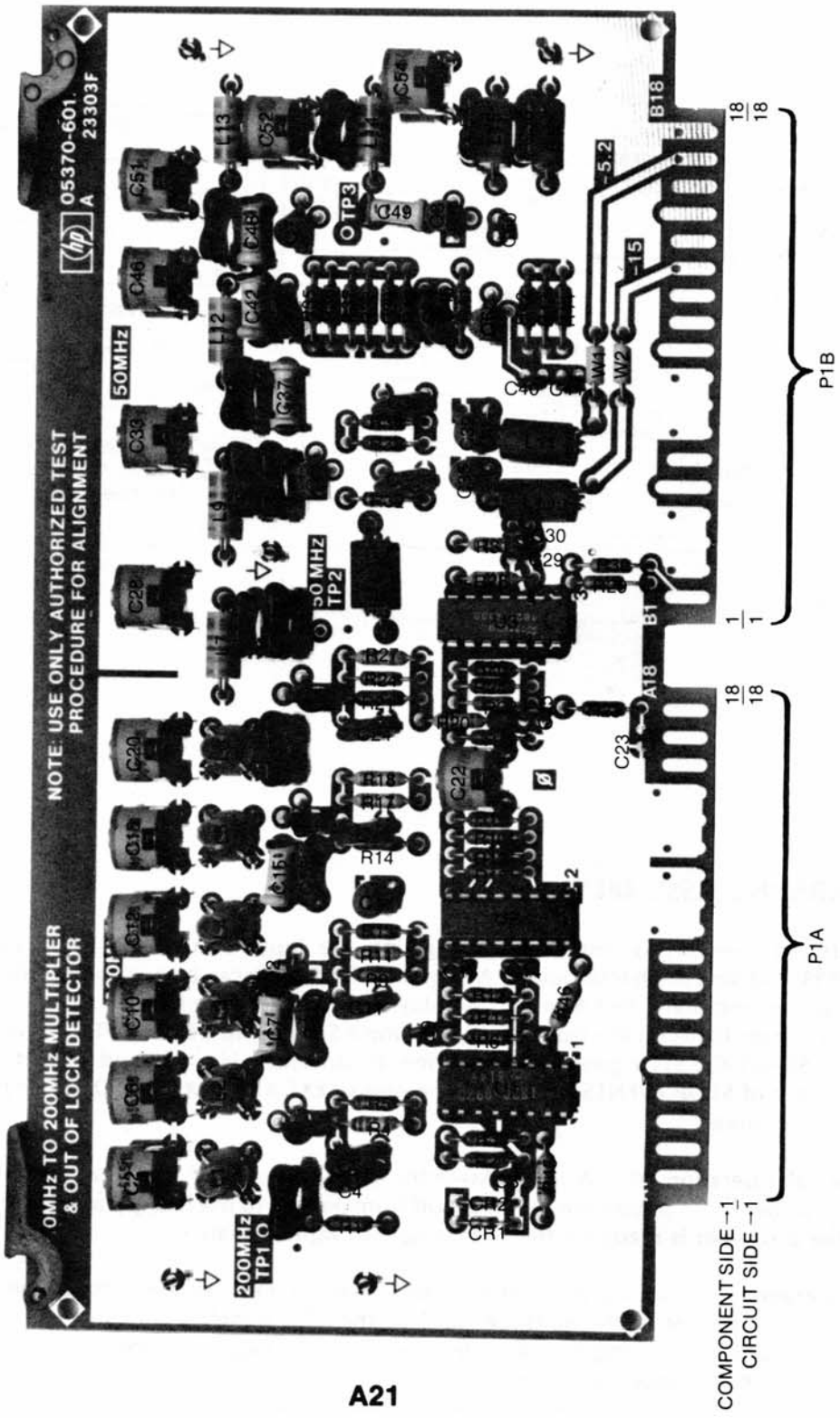

First part of page 8-107, which folds out.

A21 200 MHz MULTIPLIER (05370-60124) Series 2740

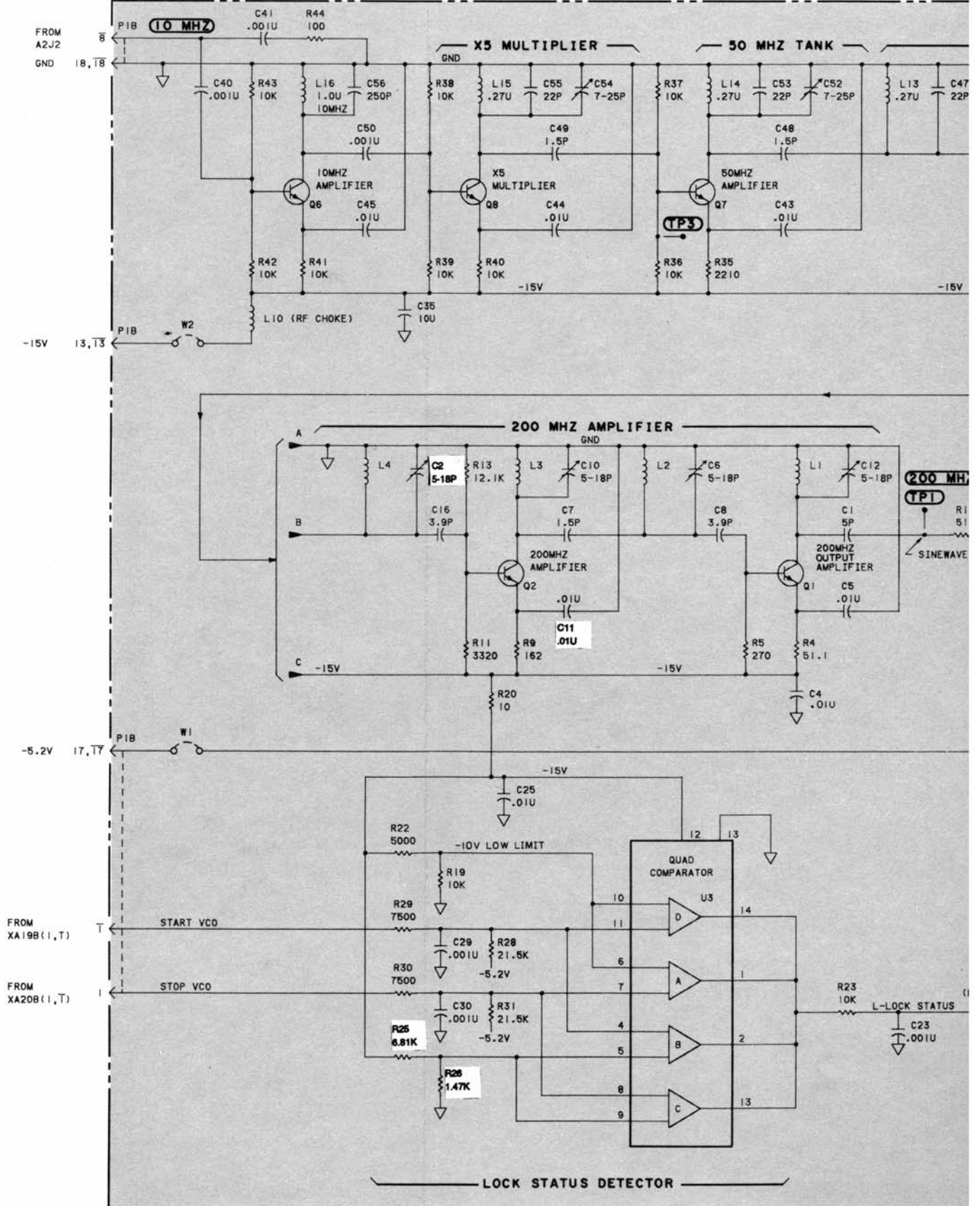

Second part of page 8-107, which folds out.

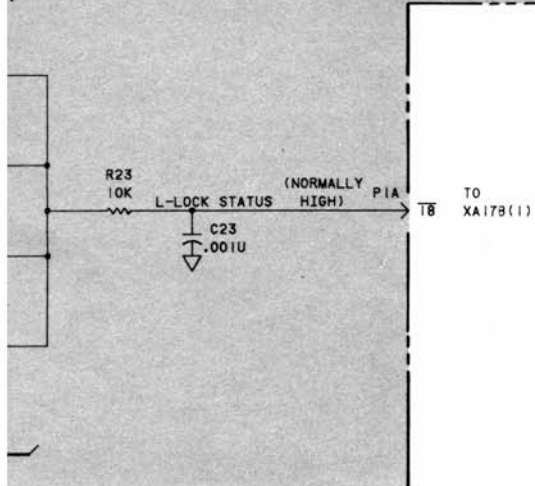
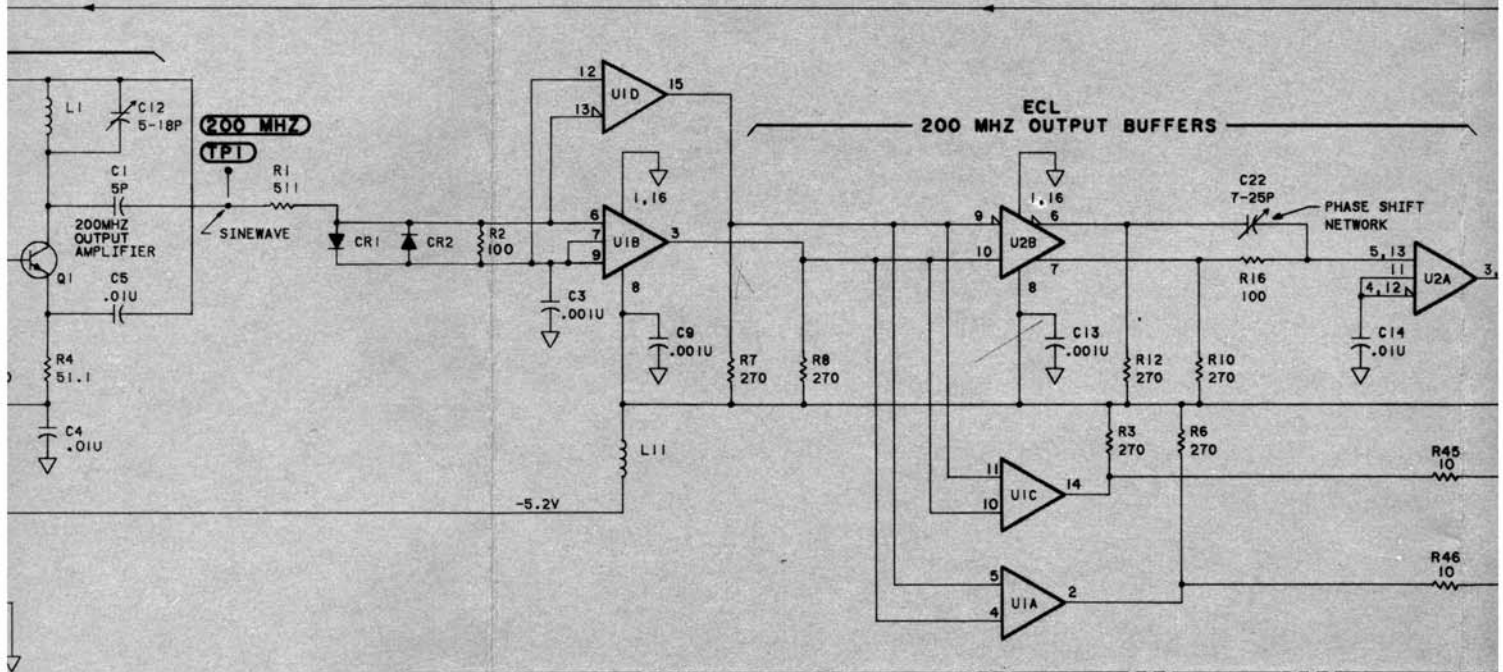
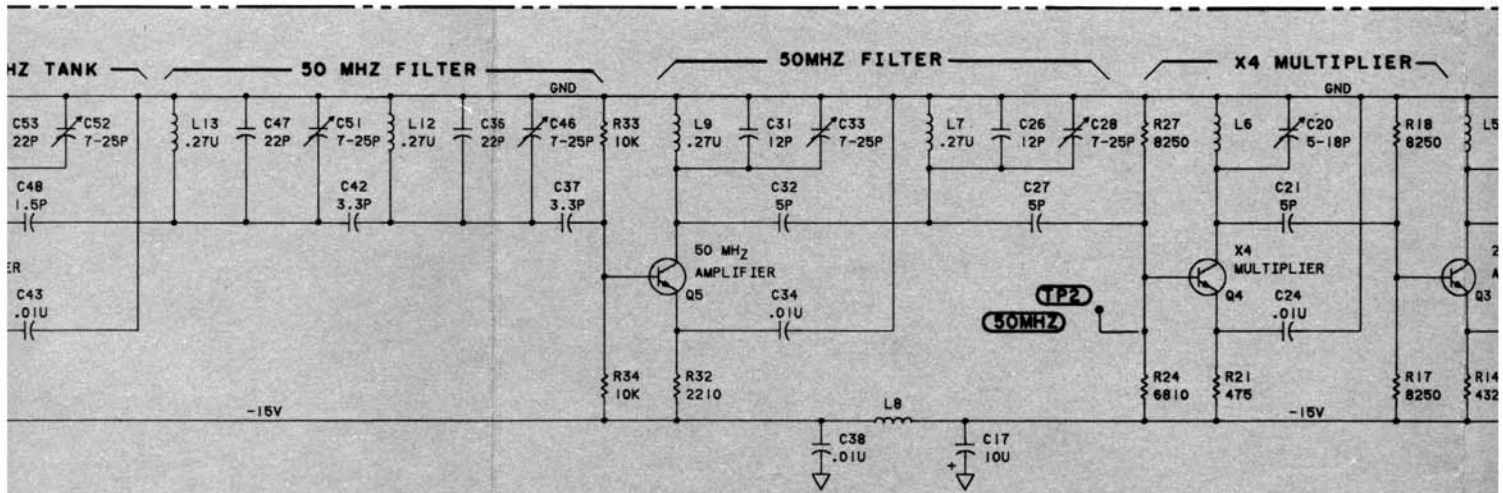

Third part of page 8-107, which folds out.

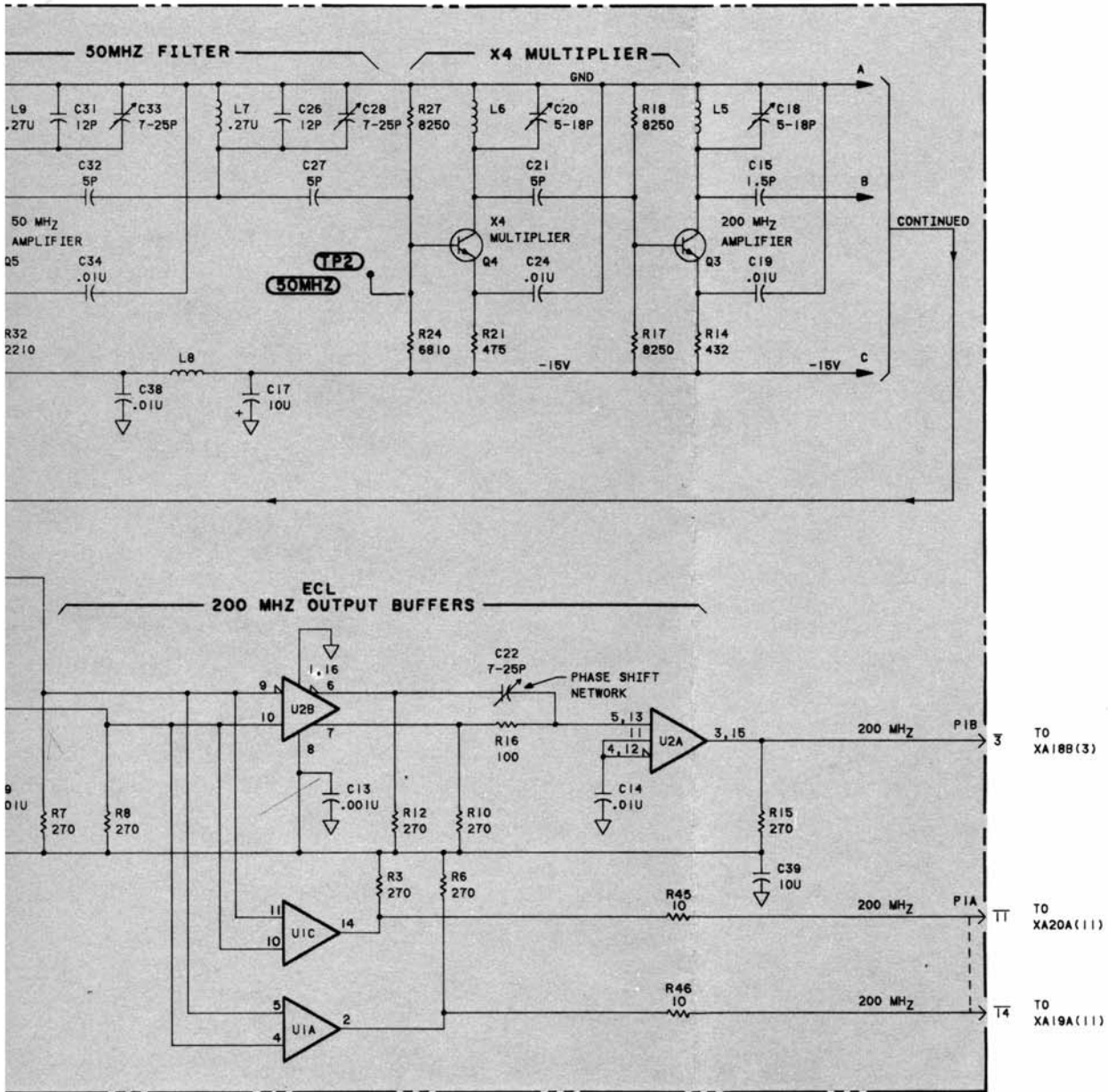

Fourth part of page 8-107, which folds out.

Figure 8-34. A21 200

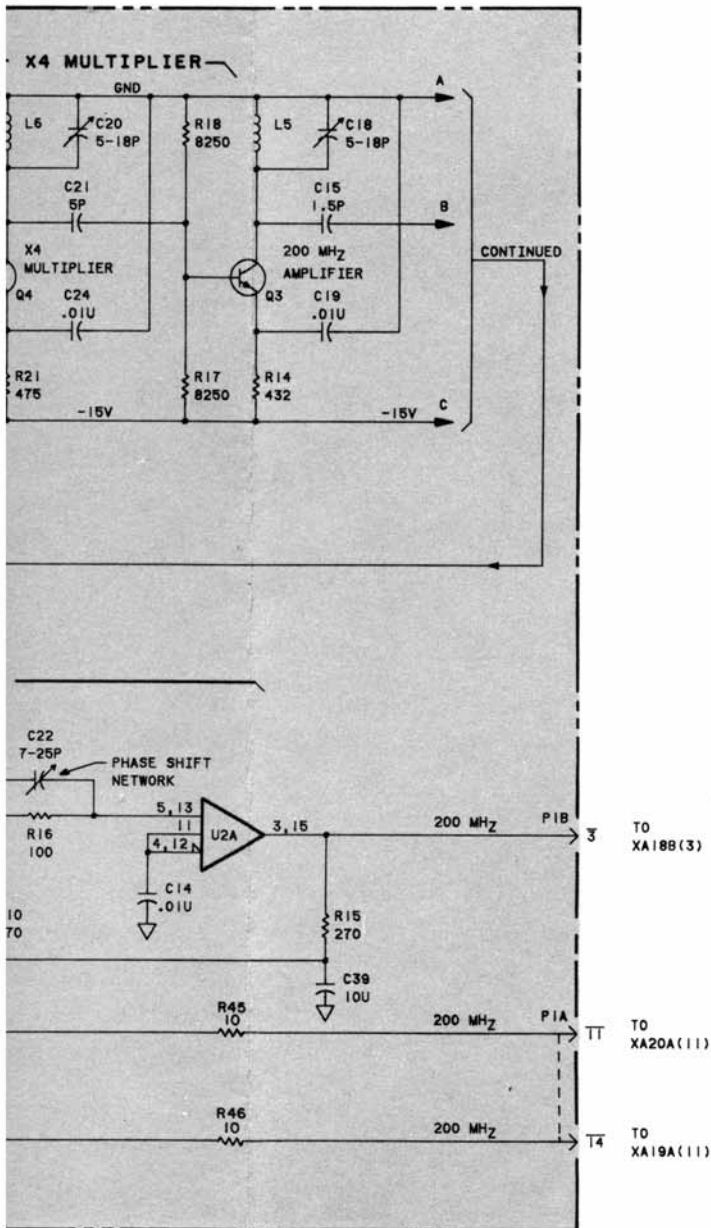

NOTES

1. REFERENCE DESIGNATIONS WITHIN THIS ASSEMBLY ARE ABBREVIATED. ADD ASSEMBLY NUMBER TO ABBREVIATION FOR COMPLETE DESCRIPTION
2. UNLESS OTHERWISE INDICATED:
RESISTANCE IN OHMS
CAPACITANCE IN FARADS
INDUCTANCE IN HENRIES
3. ASTERISK * INDICATES SELECTED COMPONENTS, AVERAGE VALUES SHOWN

Fifth (and final) part of page 8-107, which folds out.

Figure 8-34. A21 200 MHz Multiplier Assembly

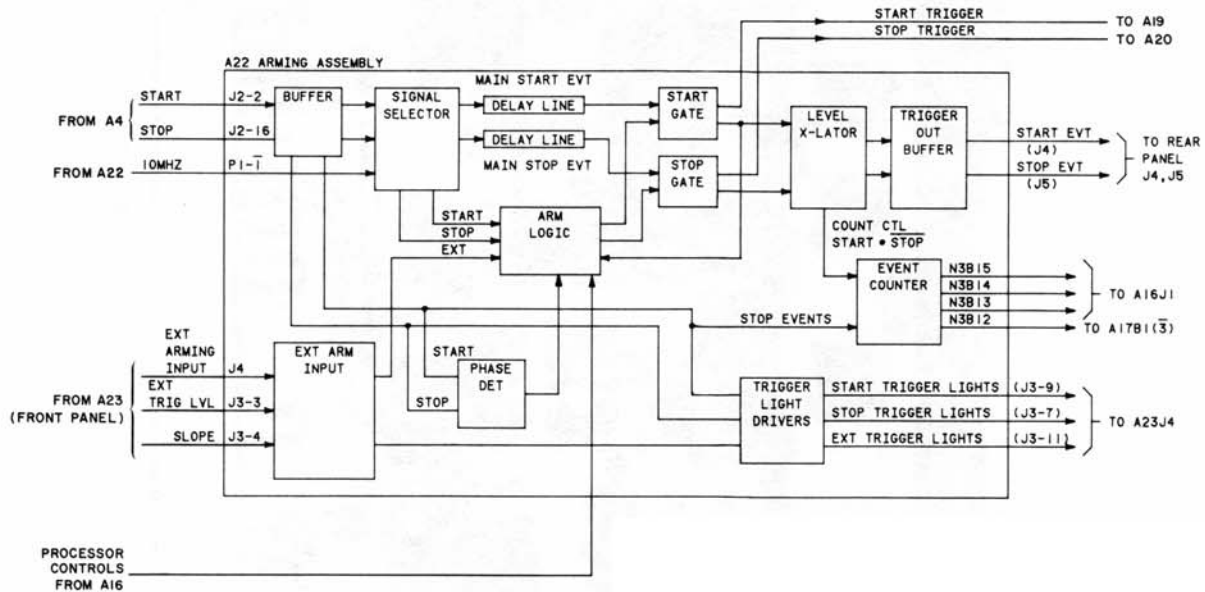

A22 ARMING ASSEMBLY

The arming assembly is responsible for gating the input START and STOP signals to the Start (A19) and Stop (A20) Interpolator Assemblies. This gating can be controlled either internally, externally, or remotely. The Arming Assembly is also responsible for driving the START, STOP, and EXT trigger lights on the front panel, sending a START and a STOP EVENT signal coincident with the START and STOP gate opening to the rear panel jacks J4 and J5, and for partially counting the number of STOP EVENTS ignored in the case of EXT ARM/EXT HOLDOFF or frequency or period gate times.

In normal operation, the Arming Assembly gates one input signal to each interpolator board. Further input signals are then held off from passing to the interpolators by the processor until the processor is ready for the next sample of input signals.

The operation is basically the same when using an EXT ARMing input signal. The EXT ARM signal is applied to the machine via J1 on the front panel. Front panel controls allow the operator to select triggering on either the positive or the negative slope. A level control selects the voltage where triggering occurs.

Part of Figure 8-35. A22 Arming Assembly

R22 on circuit side
of board.

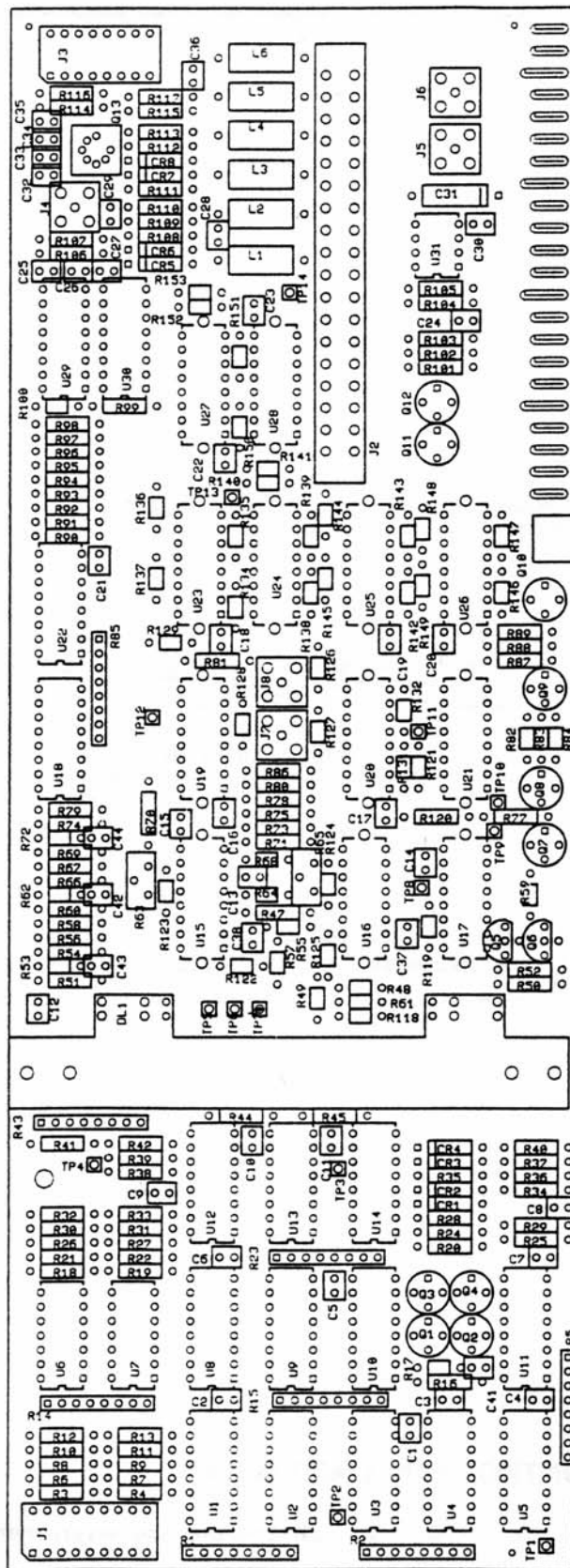

A22

First part of page 8-109, which folds out.

A22 ARMING ASSEMBLY (05370-60122) Serial Number 2940A02706 and above

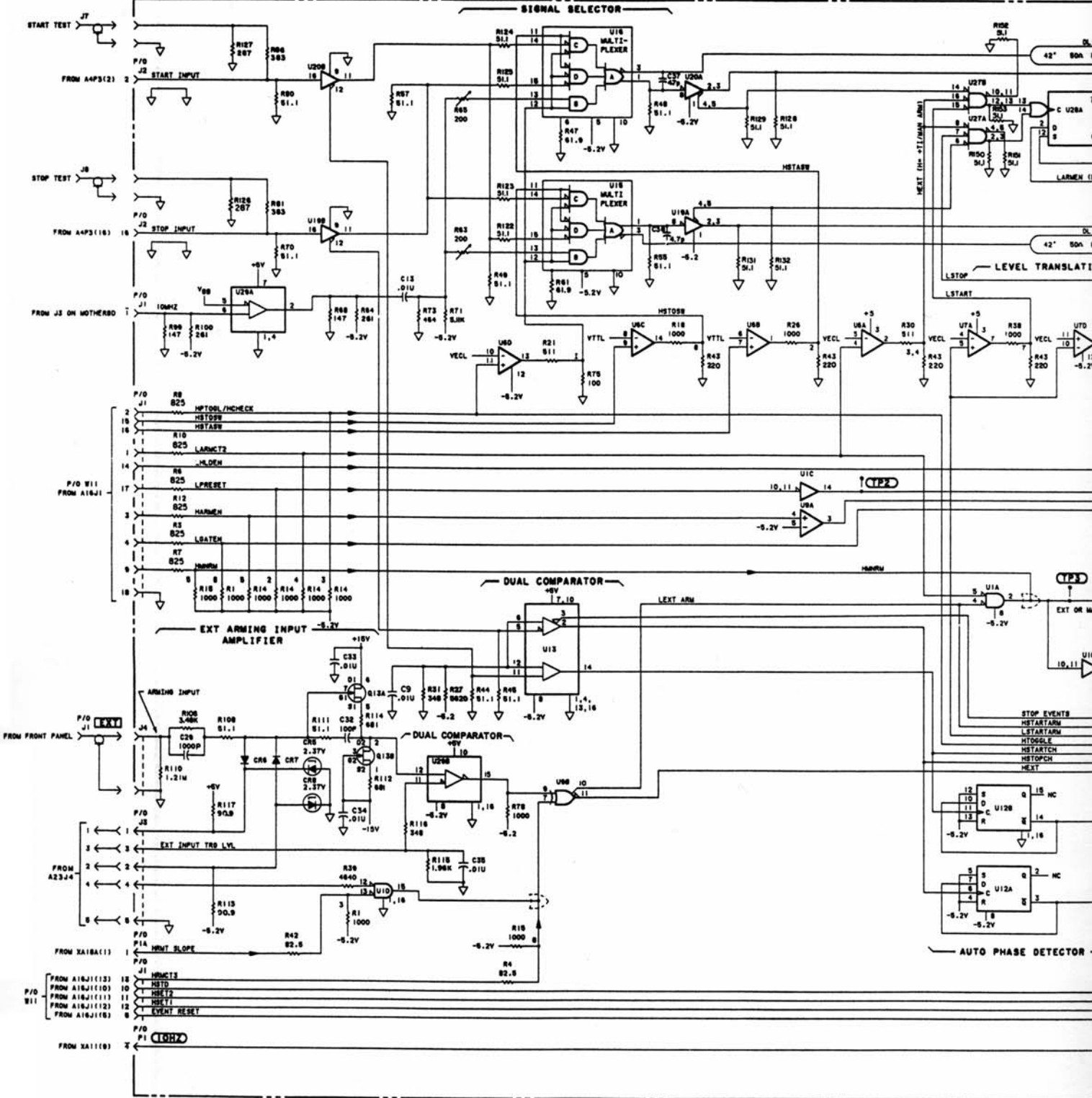

Second part of page 8-109, which folds out.

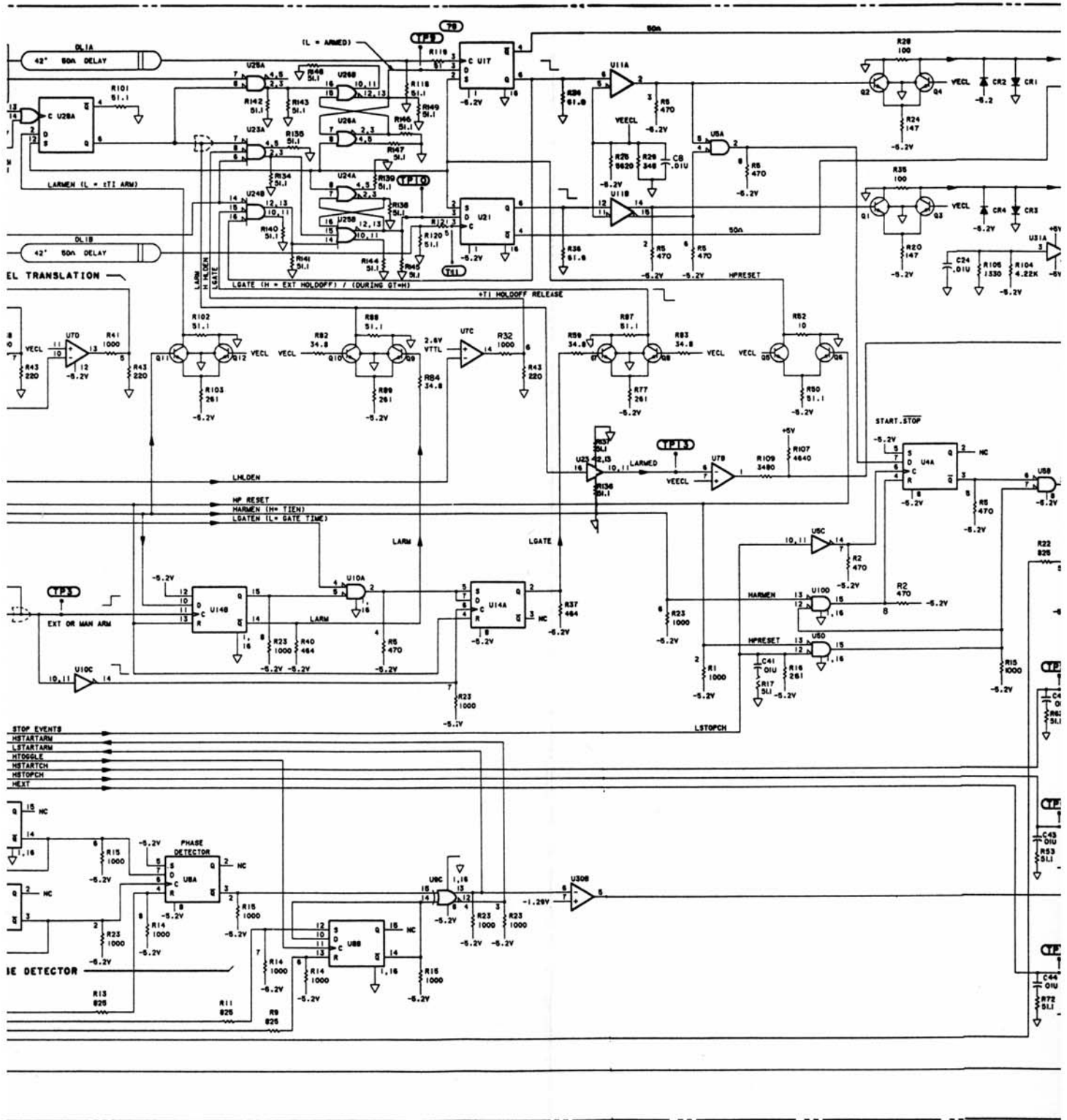

Third part of page 8-109, which folds out.

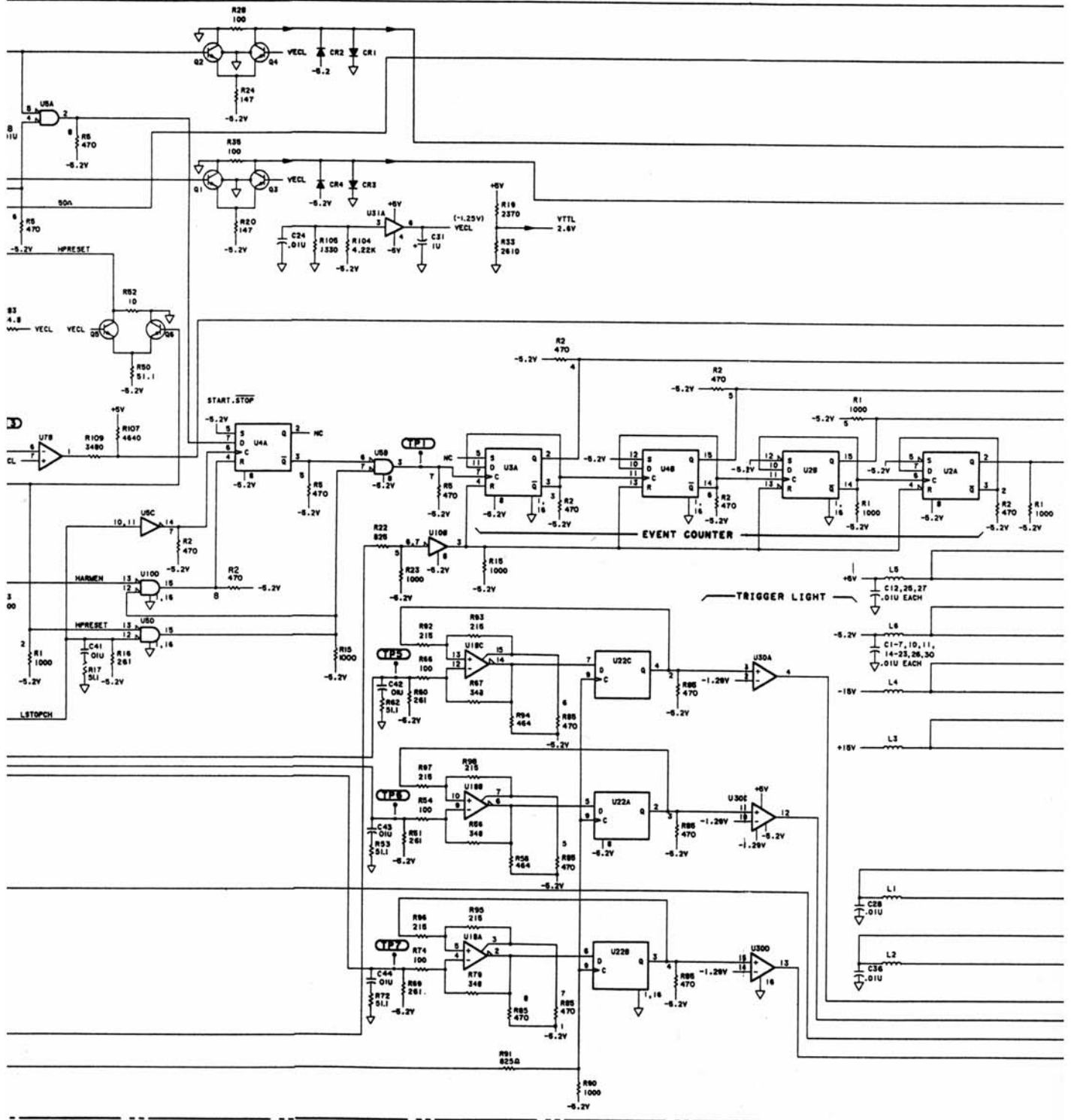

Fourth part of page 8-109, which folds out.

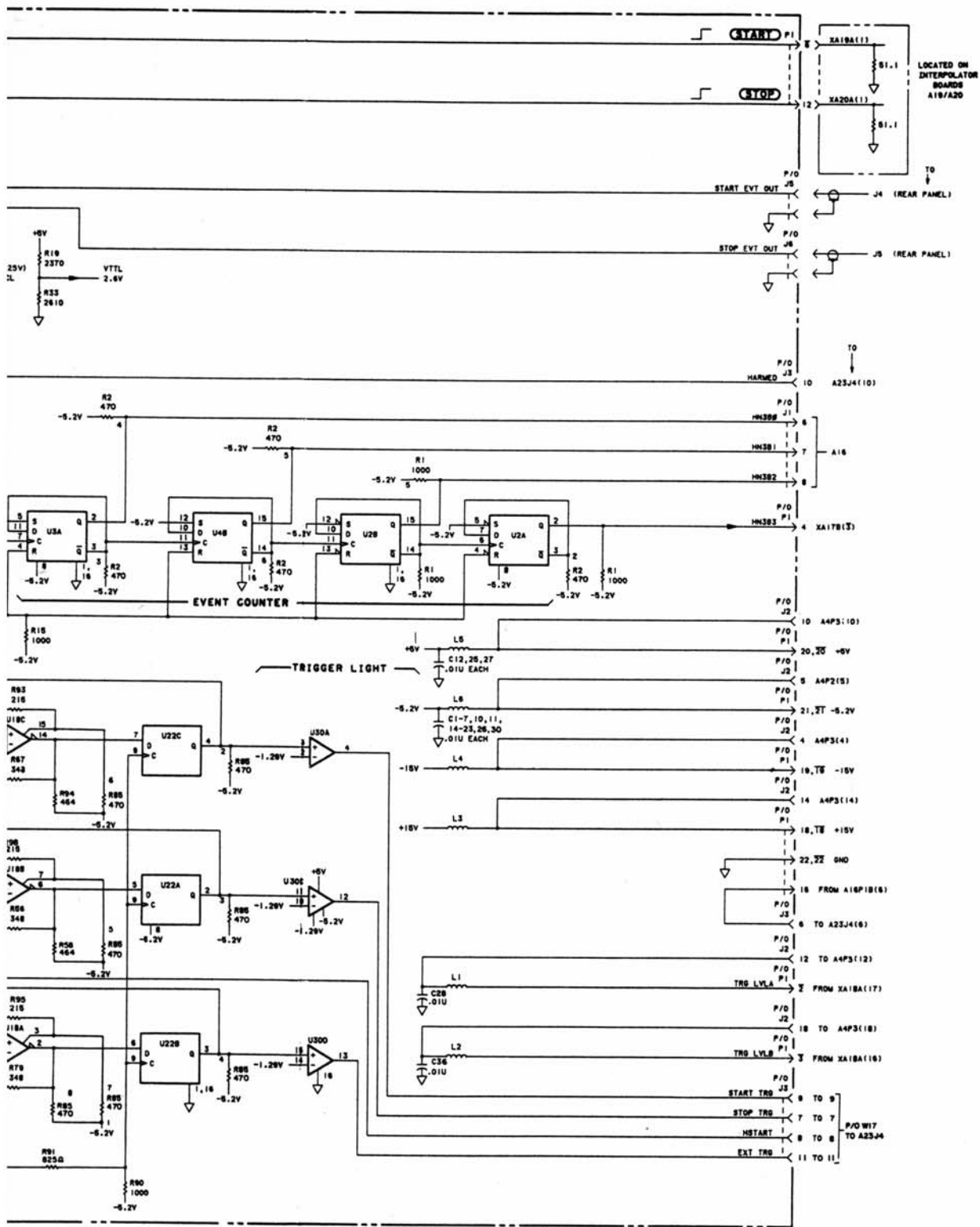

Fifth (and final) part of page 8-109, which folds out.
 Figure 8-35. A22 Arming Assembly

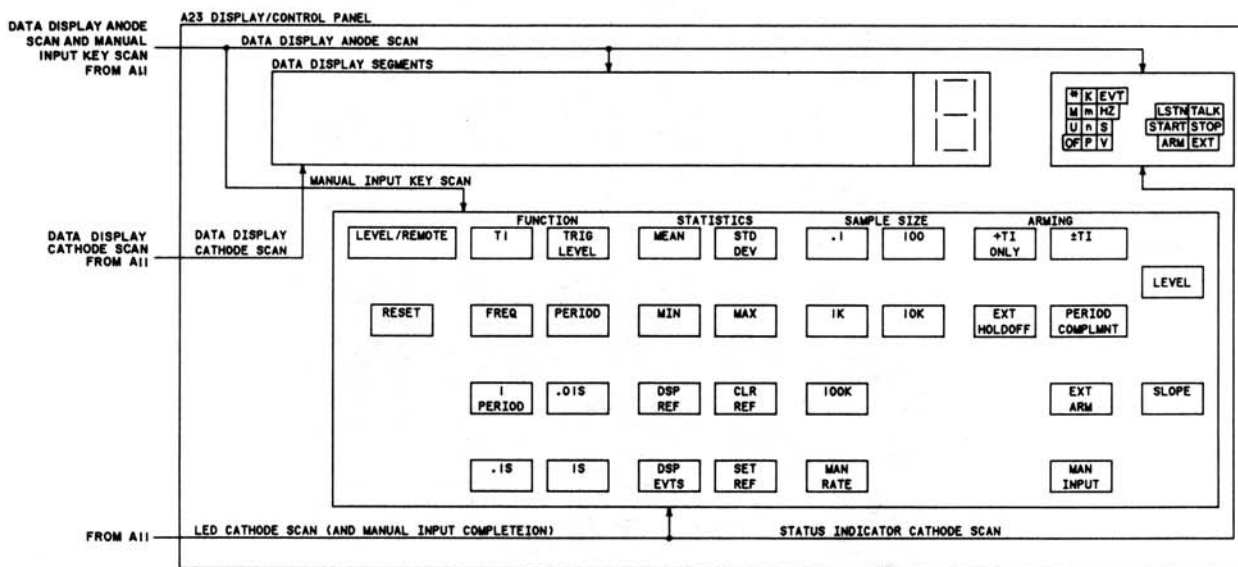

A23 DISPLAY/CONTROL PANEL ASSEMBLY

The Display/Control Panel Assembly (A23) contains the seven-segment LED displays, the LED annunciators, and the keyboard.

Part of Figure 8-36. A23 Front Panel Display/Control Assembly

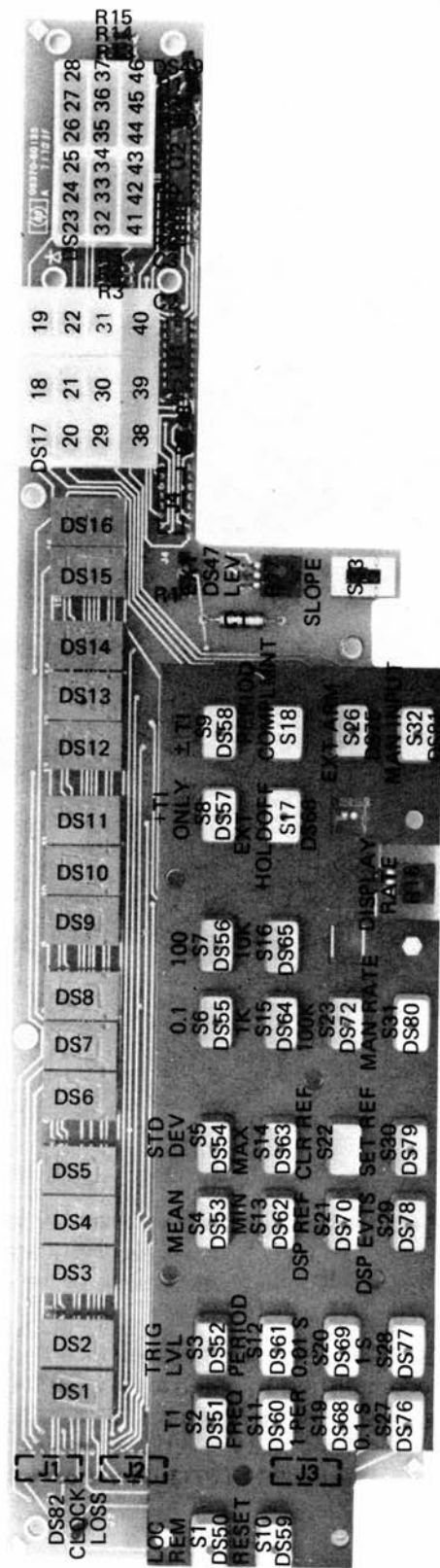

A23

First part of page 8-111, which folds out.

A23 FRONT PANEL DISPLAY ASSEMBLY (05370-60123) SERIES 2016

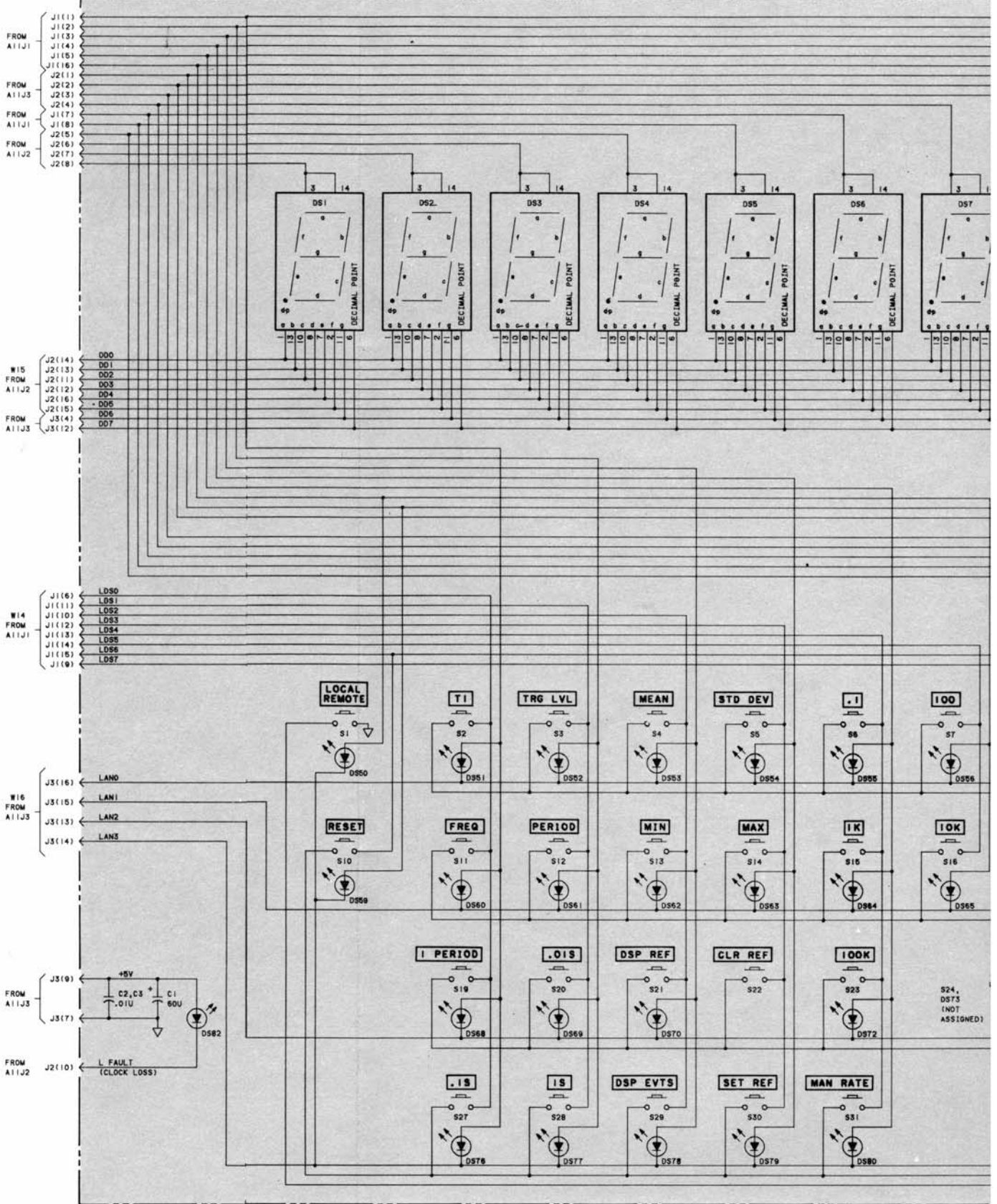

Second part of page 8-111, which folds out.

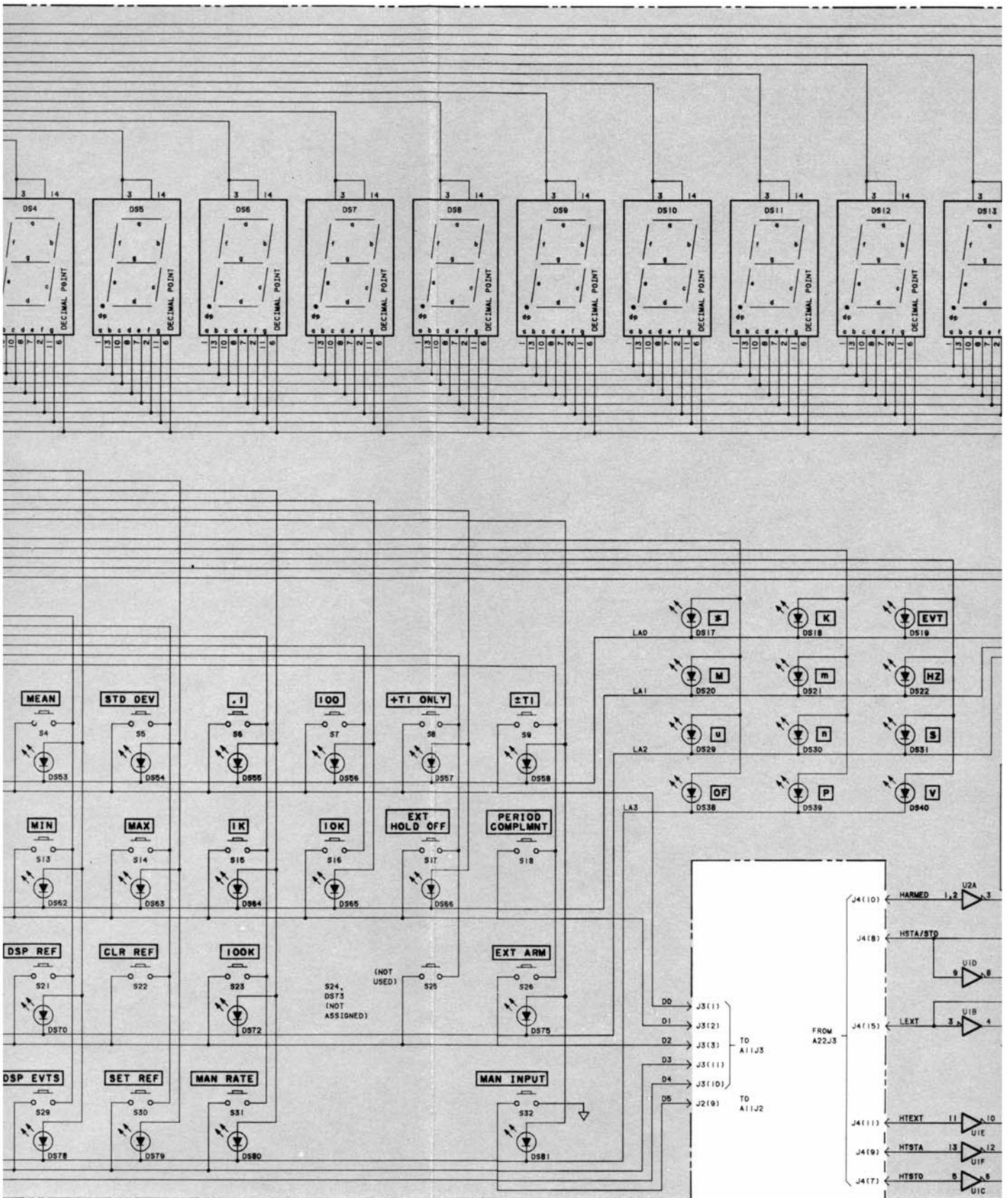

Third part of page 8-111, which folds out.

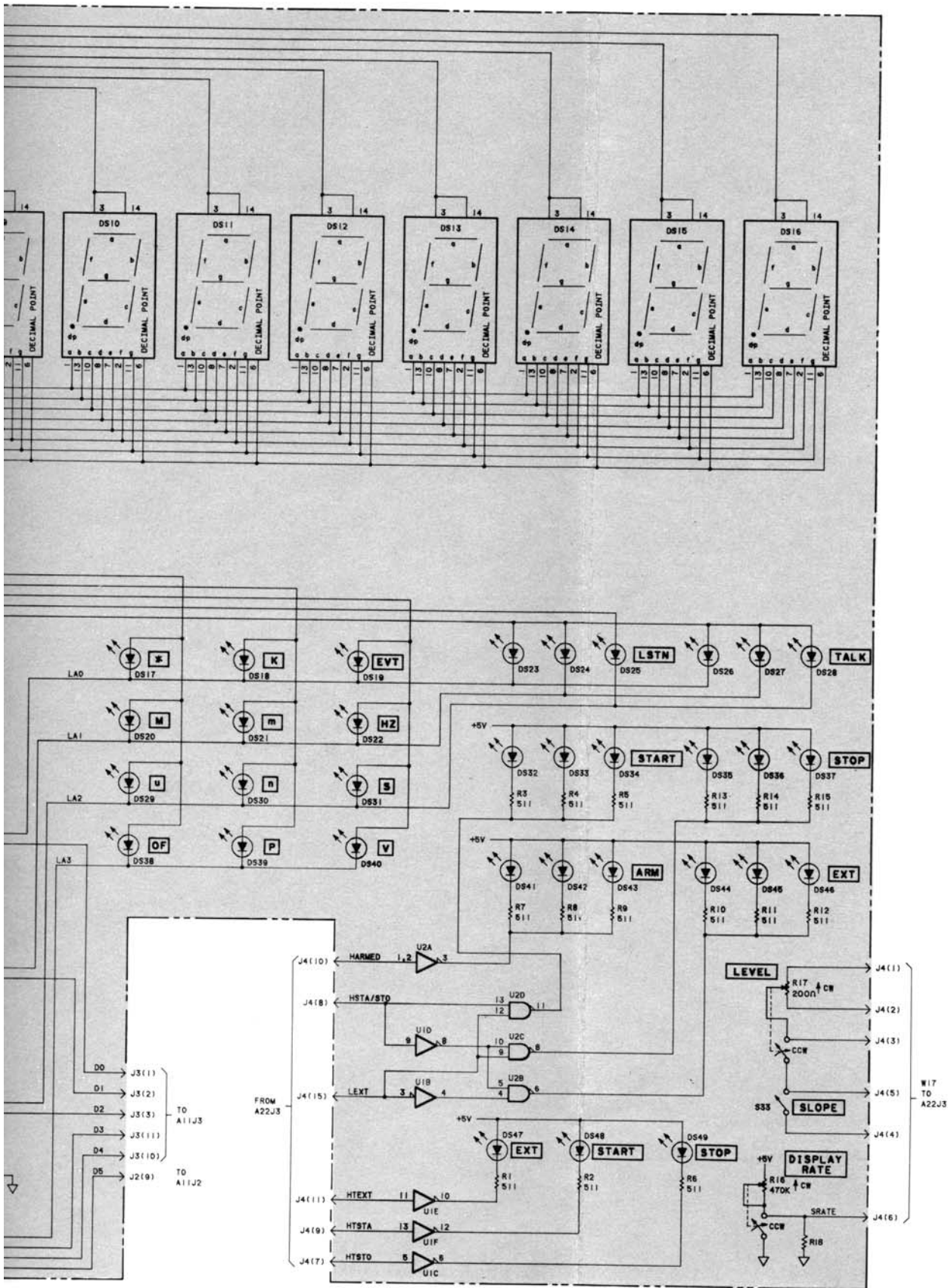

Fourth part of page 8-111, which folds out.

Figure 8-36. A23 Frc

HP 5370B
Service

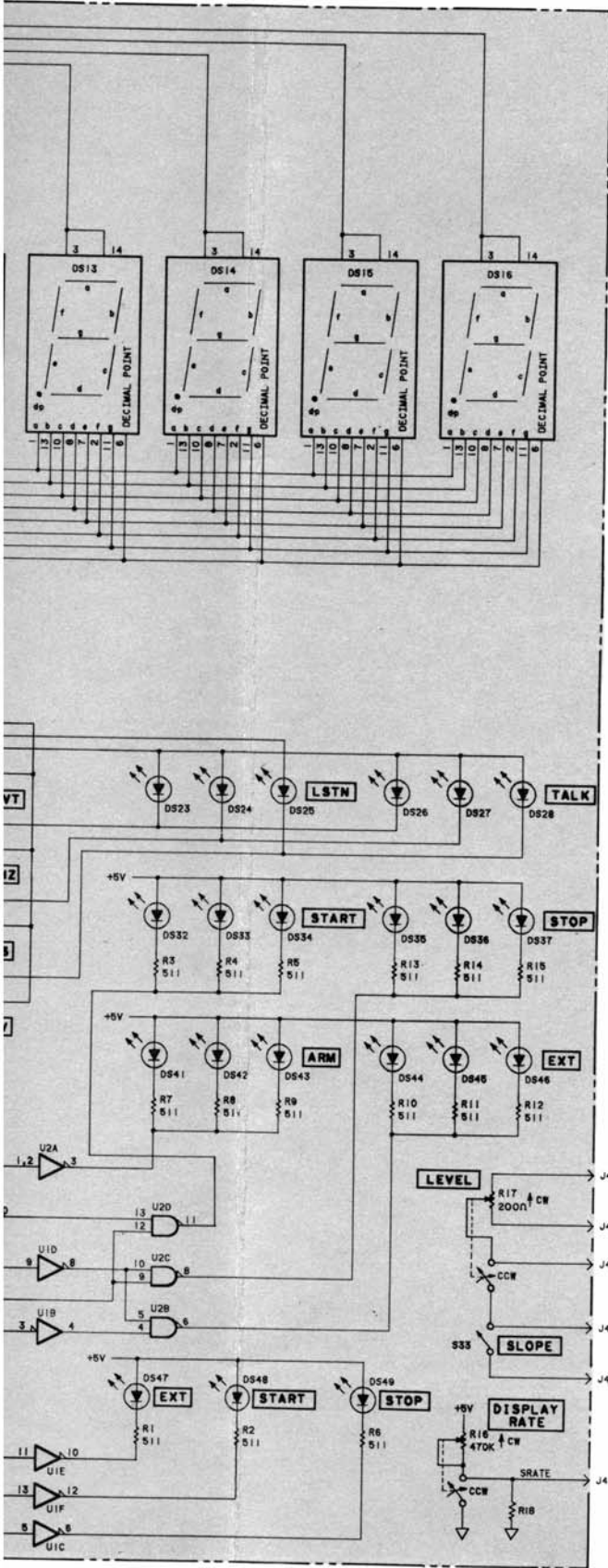

NOTES:

1. REFERENCE DESIGNATIONS WITHIN THIS ASSEMBLY ARE ABBREVIATED. ADD ASSEMBLY NUMBER TO ABBREVIATION FOR COMPLETE DESCRIPTION
2. UNLESS OTHERWISE INDICATED:
RESISTANCE IN OHMS;
CAPACITANCE IN FARADS;
INDUCTANCE IN HENRIES

Figure 8-36. A23 Front Panel Display Assembly



A69 QUARTZ CRYSTAL OVEN OSCILLATOR

NOTE

Should a failure occur in the Oscillator assembly, this assembly should be replaced with a restored unit, HP Part Number 10811-69111, or a new unit (Part Number 10811-60111). Repairs to the oscillator are strongly discouraged because of the difficulty in reconfirming the oscillator's specifications after repair.

NOTE

This assembly is held in place by two screws located on the bottom of the A2 Motherboard.

Part of Figure 8-37. A6 Quartz Crystal Oven Oscillator (10811-60111)



For more information, call your local HP sales office listed in your telephone directory or an HP regional office listed below for the location of your nearest sales office.

United States of America:

1 (800)452-4844

Rockville, MD
(301) 258 2000

Rolling Meadows, IL
(708) 255 9800

Fullerton, CA
(714) 999 6700

Atlanta, GA
(404) 955 1500

Canada:
(905) 206-4725

Japan:
(81) 426 48 0722

Latin America:
Miami, Florida
(305) 267 4245/4220

Australia
(008) 131 347 Ext. 2902
Melbourne Caller:
272 2555

New Zealand
(800) 738 378

Asia Pacific:
Hong Kong
(852) 2599 7070

Korea
(2) 769 0800

Taiwan
(2) 717 9524

Singapore
(65) 290 6375

India
(11) 647 2311

PRC
(1) 505 3888

Malaysia
(3) 298 6555

Thailand
(2) 254 6720

In Europe; Africa and Middle East, please call your local HP sales office or representative:

Austria/South East Area:
(1) 25000-0

Belgium and Luxembourg:
(02) 778 31 11

Czech Republic:
(2) 4743457

Denmark:
45 99 10 00

Finland:
(90) 88 721

France:
(1) 69.82.65.00

Germany:
(01 80) 5 32 62 22

Greece:
(01) 68 28 811

Hungary
(1) 2527220

Ireland:
(01) 284 4633

Israel:
(03) 5380 333

Italy:
(02) 92 122 999

Netherlands:
(020) 547 6669

Norway:
(22) 73 56 00

Poland
(22) 375065

Portugal:
(11) 301 73 30

Russia:
(095) 923 5001

South Africa:
(011) 806 1000

Spain:
900 123 123

Sweden:
(08) 444 20 00

Switzerland:
(01) 735 7111

Turkey:
(312) 468 8770

U.K.:
(01344) 366 666

For countries not listed, contact:

Hewlett-Packard
International Sales Europe
Geneva, Switzerland
Tel: +41-22-780-4111
Fax: +41-22-780-4770

Change Log – for the PDF file, not for the HP manual.

If problems (missing pages, unreadable pages etc) are found, I will where possible try to correct these, although since I don't own the manual, it may not be possible for me to do so.

A few pages (3-25 to 3-31) are from an older manual, since someone removed them from the manual this copy was made from. Should it be possible to change those pages for those from the October 1995 manual, I will do so.

If a newer manual is found, and someone will copy the changes, I'll stick them as an Appendix. I will **not** scan another complete manual !!

Revision 3 – 12th May, 2005

- Rescanned the 2nd and 3rd parts of page 8-63, to improve contrast.
- The second part of page 8-109 was rescanned, as the LHS was missing
- Changed the revision date on the front cover.

Revision 2 – 5th May, 2005

- Added the missing page 8-26 and 8-36.
- Added this change log
- Changed the revision date on the front cover

Revision 1 – 3rd May 5, 2005.

First release, for proof reading only.



HEWLETT®
PACKARD



Manual Part Number: 05370-90031

Printed in U.S.A.

October 1995

 Printed on recycled paper